

N207RA

2014 Cessna 208B

AIRFRAME

CESCOM

Maintenance

Transaction Records

Aircraft S/N: 208B-5098



RidgeAire
WORLDWIDE
aviation specialists

Prepared by the worldwide aviation specialists at RidgeAire, Inc.

This Maintenance Report is To Be Used Solely For (Check One)

Airframe Entries
 Eng. Serial No.
 Prop. Serial No.

Aircraft Identification and Status

A/C Serial #	A/C Registration #	Date	City ID	Total A/C Hours	Total A/C Landings	Total Engine Hrs	Total Engine Cycles	Total Prop Hrs			
208B-5098	RP-C1087	23-Mar-2023	RPLB	4001.7	6734	4001.7	6734	1676.9			

Component Changes, Inspections, Service Bulletins, or Airworthiness Directives Accomplished

Item	Transaction No.	Type	Item Name	Position	Part Number / Alternate Part	Mod Level	Part Serial	Removal Reason	Installed Part Status	TSN/TSO/TSR	Material Costs	Man Hours
B262001	1	2	WEIGHT CHECK FORWARD FIRE EXTINGUISHER PORTABLE WEIGHT CHECK Date: 23-Mar-2023 Comments:	FORWARD	C352TS		Y-649628					
5-15-10	2	2	INSPECTION DOCUMENT 10 Comments: NO FAULT FOUND.									
5-15-09	3	2	INSPECTION DOCUMENT 09 Comments: NO FAULT FOUND.									
5-15-01	4	2	INSPECTION DOCUMENT 01 Comments: NO FAULT FOUND.									
5-15-06	5	2	INSPECTION DOCUMENT 06 Comments: NO FAULT FOUND.									
760000	6	2	NO. 1 ENGINE - DOWNLOAD ECTM Comments:									
053401	7	2	UPDATE G1000 NAV DATA Comments:									

Trans Type: 1 - Component, 2 - Inspection, 3 - SB, 4 - AD, -- Misc.
 Removal Reasons: WO - Worn to Limits, SC - Scheduled, UN - Unscheduled, CO - Convenience, N - Other(note in comments)
 Installed Part Status: N - New, R - Repaired / Rebuilt, S - Serviceable, O - Overhauled, T - Tested, M - Modified, I - Inspected

Repair Facility	AIR JUAN AVIATION INC.	Certified Repair Station Number	135-14	Work Order No.	S23-003
Work Performed By	EMERSON PEROCHO	Certificate No.	013397	Date	23-Mar-2023
I certify that the above stated maintenance and/or inspection was performed in accordance with the current regulations of the <input type="checkbox"/> Federal Aviation Administration <input checked="" type="checkbox"/> Other (Specify) CAAP and					
THE AIRCRAFT IDENTIFIED ABOVE IS PRESENTLY AIRWORTHY AND APPROVED FOR RETURN TO SERVICE.					
Work Inspected By	JASON DAYRIT	Certificate No.	102495	Date	23-Mar-2023
Pertinent details of this maintenance are on file at our facility under the above Work/Service Order Number as applicable.					

Maintenance Log	
Book	Page

This Maintenance Report is To Be Used Solely For (Check One)

Airframe Entries
 Eng. Serial No.
 Prop. Serial No.

Aircraft Identification and Status

A/C Serial #	A/C Registration #	Date	City ID	Total A/C Hours	Total A/C Landings	Total Engine Hrs	Total Engine Cycles	Total Prop Hrs			
208B-5098	RP-C1087	02-Dec-2022	RPLB	4001.7	6734	4001.7	6734	1676.9			

Component Changes, Inspections, Service Bulletins, or Airworthiness Directives Accomplished

Item	Transaction No.	Type	Item Name	Position	Part Number / Alternate Part	Mod Level	Part Serial	Removal Reason	Installed Part Status	TSN/TSO/TSR	Material Costs	Man Hours
760000	1	2	NO. 1 ENGINE - DOWNLOAD ECTM									
Comments:												
053401	2	2	UPDATE G1000 NAV DATA									
Comments:												

Trans Type: 1 - Component, 2 - Inspection, 3 - SB, 4 - AD, -- Misc.
 Removal Reasons: WO - Worn to Limits, SC - Scheduled, UN - Unscheduled, CO - Convenience, N - Other(note in comments)
 Installed Part Status: N - New, R - Repaired / Rebuilt, S - Serviceable, O - Overhauled, T - Tested, M - Modified, I - Inspected

Repair Facility	AIR JUAN AVIATION INC.	Certified Repair Station Number	135-14	Work Order No.	S22-103
Work Performed By	EMERSON PEROCHO	Certificate No.	013397	Date	02-Dec-2022
I certify that the above stated maintenance and/or inspection was performed in accordance with the current regulations of the <input type="checkbox"/> Federal Aviation Administration <input checked="" type="checkbox"/> Other (Specify) _____ CAAP _____ and _____					
THE AIRCRAFT IDENTIFIED ABOVE IS PRESENTLY AIRWORTHY AND APPROVED FOR RETURN TO SERVICE.					
Work Inspected By	JASON DAYRIT	Certificate No.	102495	Date	02-Dec-2022
Pertinent details of this maintenance are on file at our facility under the above Work/Service Order Number as applicable.					

Maintenance Log	
Book	Page



Maintenance Transaction Record

CAMP MTR ID # 3869043



This Maintenance Report is To Be Used Solely For (Check One)

Airframe Entries

Eng. Serial No.

Prop. Serial No.

Aircraft Identification and Status

A/C Serial #	A/C Registration #	Date	City ID	Total A/C Hours	Total A/C Landings	Total Engine Hrs	Total Engine Cycles	Total Prop Hrs			
208B-5098	RP-C1087	04-Nov-2022	RPLB	3989.7	6716	3989.7	6716	1664.9			

Component Changes, Inspections, Service Bulletins, or Airworthiness Directives Accomplished

053401 1 2 UPDATE G1000 NAV DATA

Comments:

760000 2 2 NO. 1 ENGINE - DOWNLOAD ECTM

Comments:

790070 3 2 NO. 1 ENGINE - GENERAL VISUAL INSPECTION AGB INTERNAL SCAVENGE OIL PUMP INLET SCREEN

Comments: NO FAULT FOUND.

5-15-20 4 2 INSPECTION DOCUMENT 20

Comments: FUNCTIONAL CHECK ARTEX C460-N PERFORMED BY AVIATION HUB.

B345001 5 2 CALIBRATION TEST NO. 1 TRANSPONDER NO. 1 011-00779-10 89128030
(FAR 91.413)

CALIBRATION Date: 04-Nov-2022
Comments: PERFORMED BY AVIATION HUB.

B345001 6 2 CALIBRATION TEST NO. 2 TRANSPONDER NO. 2 011-00779-10 89127200
(FAR 91.413)

CALIBRATION Date: 04-Nov-2022
Comments: PERFORMED BY AVIATION HUB.

Trans Type: 1 - Component, 2 - Inspection, 3 - SB, 4 - AD, -- Misc. Removal Reasons: WO - Worn to Limits, SC - Scheduled, UN - Unscheduled, CO - Convenience, N - Other(note in comments)

Installed Part Status: N - New, R - Repaired / Rebuilt, S - Serviceable, O - Overhauled, T - Tested, M - Modified, I - Inspected

AIR JUAN AVIATION INC.

135-14

S22-102

NESTOR DERPO

119184

04-Nov-2022

I certify that the above stated maintenance and/or inspection was performed in accordance with the current regulations of the

Federal Aviation Administration

Other (Specify)

CAAP

and

THE AIRCRAFT IDENTIFIED ABOVE IS PRESENTLY AIRWORTHY AND APPROVED FOR RETURN TO SERVICE.

JASON DAYRIT

102495

04-Nov-2022

Pertinent details of this maintenance are on file at our facility under the above Work/Service Order Number as applicable.

Maintenance Log

Book

Page

This Maintenance Report is To Be Used Solely For (Check One)

Airframe Entries

Eng. Serial No.

Prop. Serial No.

Aircraft Identification and Status

A/C Serial #	A/C Registration #	Date	City ID	Total A/C Hours	Total A/C Landings	Total Engine Hrs	Total Engine Cycles	Total Prop Hrs			
208B-5098	RP-C1087	04-Nov-2022	RPLB	3989.7	6716	3989.7	6716	1664.9			

Component Changes, Inspections, Service Bulletins, or Airworthiness Directives Accomplished

B341103 7 2 CALIBRATION TEST STANDBY ALTIMETER STANDBY (FAR 91.411) 5934PAD-3DA,657 502525

Comments: PERFORMED BY AVIATION HUB.

B341103 8 2 FUNCTION CHECK RIGHT HAND PITOT/STATIC SYSTEM (91.411) RIGHT HAND

Comments: PERFORMED BY AVIATION HUB.

B341103 9 2 FUNCTION CHECK LEFT HAND PITOT/STATIC SYSTEM (91.411) LEFT HAND

Comments: PERFORMED BY AVIATION HUB.

Trans Type: 1 - Component, 2 - Inspection, 3 - SB, 4 - AD, -- Misc. Removal Reasons: WO - Worn to Limits, SC - Scheduled, UN - Unscheduled, CO - Convenience, N - Other(note in comments) Installed Part Status: N - New, R - Repaired / Rebuilt, S - Serviceable, O - Overhauled, T - Tested, M - Modified, I - Inspected

<u>AIR JUAN AVIATION INC.</u>	<u>135-14</u>	<u>S22-102</u>
<u>NESTOR DERPO</u>	<u>119184</u>	<u>04-Nov-2022</u>

I certify that the above stated maintenance and/or inspection was performed in accordance with the current regulations of the

Federal Aviation Administration Other (Specify) CAAP and

THE AIRCRAFT IDENTIFIED ABOVE IS PRESENTLY AIRWORTHY AND APPROVED FOR RETURN TO SERVICE.

<u>JASON DAYRIT</u>	<u>102495</u>	<u>04-Nov-2022</u>
---------------------	---------------	--------------------

Pertinent details of this maintenance are on file at our facility under the above Work/Service Order Number as applicable.

Maintenance Log	
Book	Page



CAAP APPROVED AMO 151-16

AVIONICS LOGBOOK CERTIFICATE

JOB NO.	AHAI22-AV-0066
A/C REG.	RP-C 1087
OWNER	AIR JUAN AVIATION INC.
DATE	November 4, 2022

MAKE	TEXTRON AVIATION INC.	MAKE/MODEL	N/A		MAKE	N/A	
MODEL	CESSNA GRAND CARAVAN EX 208B	SN	N/A	SN	N/A	MODEL	N/A
		TSN	N/A	TSN	N/A	LH PROP	SN
		TSO	N/A	TSO	N/A		TSN
		CSN	N/A	CSN	N/A		TSO
		CSO	N/A	CSO	N/A	RH PROP	SN
		TSHSI	N/A	TSHSI	N/A		TSN
		CSHSI	N/A	CSHSI	N/A		TSO

(THE WORK DETAILED BELOW HAS BEEN CARRIED-OUT ON THE ABOVE)

PERFORMED ALTIMETER PITOT-STATIC SYSTEM TEST USING BARFIELD PITOT-STATIC TEST EQUIPMENT TO VERIFY PROPER OPERATION AND IN COMPLIANCE WITH CAAP CAR PART 8.2.1.7 (a)(3). SYSTEM WAS TESTED UP TO 16,000 FT ALTITUDE AND BEEN FOUND SATISFACTORY.

PERFORMED TRANSPONDER MODE AIRCRAFT TEST USING BARFIELD AND ATC600A TEST EQUIPMENT TO VERIFY PROPER OPERATION AND IN COMPLIANCE WITH CAAP CAR PART 8.2.1.7 (a)(4). TRANSPONDER WAS TESTED UP TO 16,000 FT ALTITUDE AND SYSTEM BEEN FOUND SATISFACTORY.

PERFORMED ELT INSPECTION AND FUNCTIONAL TEST USING ELT TESTER EQUIPMENT TO VERIFY PROPER OPERATION AND IN COMPLIANCE WITH CAAP CAR PART 8.2.1.7 (a)(5). SYSTEM BEEN FOUND SATISFACTORY.

***** UNIT DETAILS *****

UNIT	PART NUMBER	SERIAL NUMBER	UNIT	PART NUMBER	SERIAL NUMBER
AIR DATA COMPUTER (1)	011-0088-10	20623184	AIR SPEED INDICATOR	S3325-10	T56254 B
AIR DATA COMPUTER (2)	011-00882-10	20606635	ALTIMETER INDICATOR	S3828-1	502525
TRANSPONDER (1)	011-00779-10	81128030			
TRANSPONDER (2)	011-00779-10	89127200			
ELT	453-5060	14616			

***** EQUIPMENT USED AND ITS CALIBRATION EXPIRATION *****

EQUIPMENT	MODEL	SERIAL NUMBER	RECALIBRATION DUE DATE
BARFIELD PITOT-STATIC TEST SET	1811G645	657	April 13, 2023
TRANSPONDER RAMP TEST SET	ATC600A	1392	April 13, 2023
ICARUS ELT TESTER	ELTT-124	14259	December 30, 2023

***** NOTHING FOLLOWS *****

Test Performed By: NABONG ALONZO C. 138284-AMS
 Avionics Technician
 Name / License Number

I hereby certify that the inspection/ Overhaul/ Repair/ Replacement/ Modification specified above has been carried-out in accordance with current Civil Air Regulations and was found airworthy for return to service.

Signed FERNAN B. SUNDIANG 111302-AMS for AviationHubAsia, Inc. AMO No. 151-16 Dated 04-Nov-22

NOTE: This Certificate constitutes a logbook entry and must be affixed in appropriate logbook.



Maintenance Transaction Record

CAMP MTR ID # 3775403



This Maintenance Report is To Be Used Solely For (Check One)

Airframe Entries
 Eng. Serial No.
 Prop. Serial No.

Aircraft Identification and Status

A/C Serial #	A/C Registration #	Date	City ID	Total A/C Hours	Total A/C Landings	Total Engine Hrs	Total Engine Cycles	Total Prop Hrs			
208B-5098	RP-C1087	10-Aug-2022	RPLB	3976.4	6698	3976.4	6698	1651.6			

Component Changes, Inspections, Service Bulletins, or Airworthiness Directives Accomplished

Item	Transaction No.	Type	Item Name	Position	Part Number / Alternate Part	Mod Level	Part Serial	Removal Reason	Installed Part Status	TSN/TSO/TSR	Material Costs	Man Hours
------	-----------------	------	-----------	----------	------------------------------	-----------	-------------	----------------	-----------------------	-------------	----------------	-----------

053401 1 2 UPDATE G1000 NAV DATA

Comments:

Trans Type: 1 - Component, 2 - Inspection, 3 - SB, 4 - AD, -- Misc. Removal Reasons: WO - Worn to Limits, SC - Scheduled, UN - Unscheduled, CO - Convenience, N - Other(note in comments) Installed Part Status: N - New, R - Repaired / Rebuilt, S - Serviceable, O - Overhauled, T - Tested, M - Modified, I - Inspected

Repair Facility	AIR JUAN AVIATION INC.	Certified Repair Station Number	135-14	Work Order No.	S22-097
Work Performed By	EMERSON PEROCHO	Certificate No.	013397	Date	10-Aug-2022
I certify that the above stated maintenance and/or inspection was performed in accordance with the current regulations of the <input type="checkbox"/> Federal Aviation Administration <input checked="" type="checkbox"/> Other (Specify) CAAP _____ and THE AIRCRAFT IDENTIFIED ABOVE IS PRESENTLY AIRWORTHY AND APPROVED FOR RETURN TO SERVICE.					
Work Inspected By	JASON DAYRIT	Certificate No.	102495	Date	10-Aug-2022
Pertinent details of this maintenance are on file at our facility under the above Work/Service Order Number as applicable.					

Maintenance Log	
Book	Page

Maintenance Transaction Record

CAMP MTR ID # 3747093



This Maintenance Report is To Be Used Solely For (Check One)

Airframe Entries
 Eng. Serial No.
 Prop. Serial No.

Aircraft Identification and Status

A/C Serial #	A/C Registration #	Date	City ID	Total A/C Hours	Total A/C Landings	Total Engine Hrs	Total Engine Cycles	Total Prop Hrs			
208B-5098	RP-C1087	13-Jul-2022	RPLB	3970.9	6685	3970.9	6685	1646.1			

Component Changes, Inspections, Service Bulletins, or Airworthiness Directives Accomplished

Item	Transaction No.	Type	Item Name	Position	Part Number / Alternate Part	Mod Level	Part Serial	Removal Reason	Installed Part Status	TSN/TSO/TSR	Material Costs	Man Hours
760000	1	2	NO. 1 ENGINE - DOWNLOAD ECTM									
Comments:												
053401	2	2	UPDATE G1000 NAV DATA									
Comments:												

Trans Type: 1 - Component, 2 - Inspection, 3 - SB, 4 - AD, -- Misc.
 Removal Reasons: WO - Worn to Limits, SC - Scheduled, UN - Unscheduled, CO - Convenience, N - Other (note in comments)
 Installed Part Status: N - New, R - Repaired / Rebuilt, S - Serviceable, O - Overhauled, T - Tested, M - Modified, I - Inspected

Repair Facility	AIR JUAN AVIATION	Certified Repair Station Number	135-14	Work Order No.	S22-091
Work Performed By	EMERSON PEROCHO	Certificate No.	013397	Date	13-Jul-2022
I certify that the above stated maintenance and/or inspection was performed in accordance with the current regulations of the <input type="checkbox"/> Federal Aviation Administration <input checked="" type="checkbox"/> Other (Specify) _____ CAAP _____ and THE AIRCRAFT IDENTIFIED ABOVE IS PRESENTLY AIRWORTHY AND APPROVED FOR RETURN TO SERVICE.					
Work Inspected By	JASON DAYRIT	Certificate No.	102495	Date	13-Jul-2022
Pertinent details of this maintenance are on file at our facility under the above Work/Service Order Number as applicable.					

Maintenance Log	
Book	Page



Maintenance Transaction Record

CAMP MTR ID # 3733683



This Maintenance Report is To Be Used Solely For (Check One)

Airframe Entries
 Eng. Serial No. PCE-VA0103
 Prop. Serial No.

Aircraft Identification and Status

A/C Serial #	A/C Registration #	Date	City ID	Total A/C Hours	Total A/C Landings	Total Engine Hrs	Total Engine Cycles	Total Prop Hrs			
208B-5098	RP-C1087	01-Jul-2022	RPLB	3965	6673	3965	6673	1640.2			

Component Changes, Inspections, Service Bulletins, or Airworthiness Directives Accomplished

Item	Transaction No.	Type	Item Name	Position	Part Number / Alternate Part	Mod Level	Part Serial	Removal Reason	Installed Part Status	TSN/TSO/TSR	Material Costs	Man Hours
760000	1	2	NO. 1 ENGINE - DOWNLOAD ECTM									
Comments:												
790090	2	2	NO. 1 ENGINE - GENERAL VISUAL INSPECTION CHIP DETECTOR FOR DEBRIS		PN		SN-UNKNOWN					
Comments:												
733010	3	2	NO. 1 ENGINE - GENERAL VISUAL INSPECTION PNEUMATIC P3 FILTER DRAIN VALVE									
Comments:												
5-15-07	4	2	INSPECTION DOCUMENT 07									
Comments: NO FAULT FOUND.												
733020	5	2	NO. 1 ENGINE - CLEAN/REPLACE PNEUMATIC P3 FILTER DEPENDING ON CONDITION									
Comments:												

Trans Type: 1 - Component, 2 - Inspection, 3 - SB, 4 - AD, -- Misc.
 Removal Reasons: WO - Worn to Limits, SC - Scheduled, UN - Unscheduled, CO - Convenience, N - Other(note in comments)
 Installed Part Status: N - New, R - Repaired / Rebuilt, S - Serviceable, O - Overhauled, T - Tested, M - Modified, I - Inspected

Repair Facility	<u>AIR JUAN AVIATION INC.</u>	Certified Repair Station Number	<u>135-14</u>	Work Order No.	<u>S22-084</u>
Work Performed By	<u>EMERSON PEROCHO</u>	Certificate No.	<u>013397</u>	Date	<u>01-Jul-2022</u>
I certify that the above stated maintenance and/or inspection was performed in accordance with the current regulations of the <input type="checkbox"/> Federal Aviation Administration <input checked="" type="checkbox"/> Other (Specify) <u>CAAP</u> and					
THE AIRCRAFT IDENTIFIED ABOVE IS PRESENTLY AIRWORTHY AND APPROVED FOR RETURN TO SERVICE.					
Work Inspected By	<u>JASON DAYRIT</u>	Certificate No.	<u>102495</u>	Date	<u>01-Jul-2022</u>
Pertinent details of this maintenance are on file at our facility under the above Work/Service Order Number as applicable.					

Maintenance Log	
Book	Page



Maintenance Transaction Record

CAMP MTR ID # 3715769



This Maintenance Report is To Be Used Solely For (Check One)

Airframe Entries

Eng. Serial No.

Prop. Serial No.

Aircraft Identification and Status

A/C Serial #	A/C Registration #	Date	City ID	Total A/C Hours	Total A/C Landings	Total Engine Hrs	Total Engine Cycles	Total Prop Hrs			
208B-5098	RP-C1087	16-Jun-2022	RPLB	3958.4	6663	3958.4	6663	1633.6			

Component Changes, Inspections, Service Bulletins, or Airworthiness Directives Accomplished

Item	Transaction No.	Type	Item Name	Position	Part Number / Alternate Part	Mod Level	Part Serial	Removal Reason	Installed Part Status	TSN/TSO/TSR	Material Costs	Man Hours
053401	1	2	UPDATE G1000 NAV DATA									
Comments:												
760000	2	2	NO. 1 ENGINE - DOWNLOAD ECTM									
Comments:												
370102	3	1	VACUUM SYSTEM CENTRAL AIR FILTER DISCARD		AAD-9-18-1		NSN	SC	N	0 MTH 0 HRS		
Comments: Removed part no: AAD-9-18-1 Removed serial no: NSN.												
370103	4	1	VACUUM RELIEF VALVE FILTER DISCARD		B3-5-1		NSN	SC	N	0 MTH 0 HRS		
Comments: Removed part no: C482001-0202 Removed serial no: NSN.												

Trans Type: 1 - Component, 2 - Inspection, 3 - SB, 4 - AD, -- Misc.

Removal Reasons: WO - Worn to Limits, SC - Scheduled, UN - Unscheduled, CO - Convenience, N - Other(note in comments)

Installed Part Status: N - New, R - Repaired / Rebuilt, S - Serviceable, O - Overhauled, T - Tested, M - Modified, I - Inspected

Repair Facility	AIR JUAN AVIATION INC.	Certified Repair Station Number	135-14	Work Order No.	S22-079
Work Performed By	EMERSON PEROCHO	Certificate No.	013397	Date	16-Jun-2022
I certify that the above stated maintenance and/or inspection was performed in accordance with the current regulations of the					
<input type="checkbox"/> Federal Aviation Administration					
<input checked="" type="checkbox"/> Other (Specify) CAAP and					
THE AIRCRAFT IDENTIFIED ABOVE IS PRESENTLY AIRWORTHY AND APPROVED FOR RETURN TO SERVICE.					
Work Inspected By	JASON DAYRIT	Certificate No.	102495	Date	16-Jun-2022
Pertinent details of this maintenance are on file at our facility under the above Work/Service Order Number as applicable.					

Maintenance Log	
Book	Page



Maintenance Transaction Record

CAMP MTR ID # 3685920



This Maintenance Report is To Be Used Solely For (Check One)

Airframe Entries
 Eng. Serial No.
 Prop. Serial No.

Aircraft Identification and Status

A/C Serial #	A/C Registration #	Date	City ID	Total A/C Hours	Total A/C Landings	Total Engine Hrs	Total Engine Cycles	Total Prop Hrs			
208B-5098	RP-C1087	18-May-2022	RPLB	3940.2	6638	3940.2	6638	1615.4			

Component Changes, Inspections, Service Bulletins, or Airworthiness Directives Accomplished

Item	Transaction No.	Type	Item Name	Position	Part Number / Alternate Part	Mod Level	Part Serial	Removal Reason	Installed Part Status	TSN/TSO/TSR	Material Costs	Man Hours
053401	1	2	UPDATE G1000 NAV DATA									
Comments: CYCLE: 2205												

Trans Type: 1 - Component, 2 - Inspection, 3 - SB, 4 - AD, -- Misc.
 Removal Reasons: WO - Worn to Limits, SC - Scheduled, UN - Unscheduled, CO - Convenience, N - Other(note in comments)
 Installed Part Status: N - New, R - Repaired / Rebuilt, S - Serviceable, O - Overhauled, T - Tested, M - Modified, I - Inspected

Repair Facility	AIR JUAN AVIATION INC.	Certified Repair Station Number	135-14	Work Order No.	S22-060
Work Performed By	EMERSON PEROCHO	Certificate No.	013397	Date	18-May-2022
I certify that the above stated maintenance and/or inspection was performed in accordance with the current regulations of the <input type="checkbox"/> Federal Aviation Administration <input checked="" type="checkbox"/> Other (Specify) CAAP and					
THE AIRCRAFT IDENTIFIED ABOVE IS PRESENTLY AIRWORTHY AND APPROVED FOR RETURN TO SERVICE.					
Work Inspected By	JASON DAYRIT	Certificate No.	102495	Date	18-May-2022
Pertinent details of this maintenance are on file at our facility under the above Work/Service Order Number as applicable.					

Maintenance Log	
Book	Page



Maintenance Transaction Record

CAMP MTR ID # 3643056



This Maintenance Report is To Be Used Solely For (Check One)

Airframe Entries
 Eng. Serial No.
 Prop. Serial No.

Aircraft Identification and Status

A/C Serial #	A/C Registration #	Date	City ID	Total A/C Hours	Total A/C Landings	Total Engine Hrs	Total Engine Cycles	Total Prop Hrs			
208B-5098	RP-C1087	20-Apr-2022	RPLB	3914.4	6607	3914.4	6607	1589.6			

Component Changes, Inspections, Service Bulletins, or Airworthiness Directives Accomplished

Item	Transaction No.	Type	Item Name	Position	Part Number / Alternate Part	Mod Level	Part Serial	Removal Reason	Installed Part Status	TSN/TSO/TSR	Material Costs	Man Hours
053401	1	2	UPDATE G1000 NAV DATA Comments: CYCLE 2204 EXPIRES 19 MAY 2022.									
760000	2	2	NO. 1 ENGINE - DOWNLOAD ECTM Comments:									

Trans Type: 1 - Component, 2 - Inspection, 3 - SB, 4 - AD, -- Misc.
 Removal Reasons: WO - Worn to Limits, SC - Scheduled, UN - Unscheduled, CO - Convenience, N - Other(note in comments)
 Installed Part Status: N - New, R - Repaired / Rebuilt, S - Serviceable, O - Overhauled, T - Tested, M - Modified, I - Inspected

Repair Facility	AIR JUAN AVIATION INC.	Certified Repair Station Number	135-14	Work Order No.	S22-054
Work Performed By	ERIC DE LEON	Certificate No.	110359	Date	20-Apr-2022
I certify that the above stated maintenance and/or inspection was performed in accordance with the current regulations of the <input type="checkbox"/> Federal Aviation Administration <input checked="" type="checkbox"/> Other (Specify) CAAP _____ and _____					
THE AIRCRAFT IDENTIFIED ABOVE IS PRESENTLY AIRWORTHY AND APPROVED FOR RETURN TO SERVICE.					
Work Inspected By	JASON DAYRIT	Certificate No.	102495	Date	20-Apr-2022
Pertinent details of this maintenance are on file at our facility under the above Work/Service Order Number as applicable.					

Maintenance Log	
Book	Page

Maintenance Transaction Record

CAMP MTR ID # 3613277

This Maintenance Report is To Be Used Solely For (Check One)

Airframe Entries

Eng. Serial No.

Prop. Serial No.

Aircraft Identification and Status

A/C Serial #	A/C Registration #	Date	City ID	Total A/C Hours	Total A/C Landings	Total Engine Hrs	Total Engine Cycles	Total Prop Hrs			
208B-5098	RP-C1087	23-Mar-2022	RPLB	3883.3	6574	3883.3	6574	1558.5			

Component Changes, Inspections, Service Bulletins, or Airworthiness Directives Accomplished

Item	Transaction No.	Type	Item Name	Position	Part Number / Alternate Part	Mod Level	Part Serial	Removal Reason	Installed Part Status	TSN/TSO/TSR	Material Costs	Man Hours
760000	1	2	NO. 1 ENGINE - DOWNLOAD ECTM									
Comments:												
053401	2	2	UPDATE G1000 NAV DATA									
Comments:												

Trans Type: 1 - Component, 2 - Inspection, 3 - SB, 4 - AD, -- Misc.

Removal Reasons: WO - Worn to Limits, SC - Scheduled, UN - Unscheduled, CO - Convenience, N - Other(note in comments)

Installed Part Status: N - New, R - Repaired / Rebuilt, S - Serviceable, O - Overhauled, T - Tested, M - Modified, I - Inspected

Repair Facility	AIRJUAN AVIATION INC.	Certified Repair Station Number	135-14	Work Order No.	S22-040
Work Performed By	EMERSON PEROCHO	Certificate No.	013397	Date	23-Mar-2022
<p>I certify that the above stated maintenance and/or inspection was performed in accordance with the current regulations of the</p> <p><input type="checkbox"/> Federal Aviation Administration <input checked="" type="checkbox"/> Other (Specify) _____ CAAP _____ and</p> <p>THE AIRCRAFT IDENTIFIED ABOVE IS PRESENTLY AIRWORTHY AND APPROVED FOR RETURN TO SERVICE.</p>					
Work Inspected By	JASON DAYRIT	Certificate No.	102495	Date	23-Mar-2022
<p>Pertinent details of this maintenance are on file at our facility under the above Work/Service Order Number as applicable.</p>					

Maintenance Log	
Book	Page



Maintenance Transaction Record

CAMP MTR ID # 3649248



This Maintenance Report is To Be Used Solely For (Check One)

Airframe Entries

Eng. Serial No.

Prop. Serial No.

Aircraft Identification and Status

A/C Serial #	A/C Registration #	Date	City ID	Total A/C Hours	Total A/C Landings	Total Engine Hrs	Total Engine Cycles	Total Prop Hrs			
208B-5098	RP-C1087	23-Mar-2022	RPLL	3883.3	6574	3883.3	6574	1558.5			

Component Changes, Inspections, Service Bulletins, or Airworthiness Directives Accomplished

Item	Transaction No.	Type	Item Name	Position	Part Number / Alternate Part	Mod Level	Part Serial	Removal Reason	Installed Part Status	TSN/TSO/TSR	Material Costs	Man Hours
5-15-09	1	2	INSPECTION DOCUMENT 09									
Comments: NO FAUL FOUND. PERFORMED IAW 208B MAINTENANCE MANUAL REV 37 DATED 1 MAR 2020.												

Trans Type: 1 - Component, 2 - Inspection, 3 - SB, 4 - AD, -- Misc.

Removal Reasons: WO - Worn to Limits, SC - Scheduled, UN - Unscheduled, CO - Convenience, N - Other(note in comments)

Installed Part Status: N - New, R - Repaired / Rebuilt, S - Serviceable, O - Overhauled, T - Tested, M - Modified, I - Inspected

Repair Facility	<u>AIR JUAN AVIATION INC.</u>	Certified Repair Station Number	<u>135-14</u>	Work Order No.	<u>S22-043</u>
Work Performed By	<u>ERIC DE LEON</u>	Certificate No.	<u>110359</u>	Date	<u>23-Mar-2022</u>
I certify that the above stated maintenance and/or inspection was performed in accordance with the current regulations of the <input type="checkbox"/> Federal Aviation Administration <input checked="" type="checkbox"/> Other (Specify) <u>CAAP</u> and					
THE AIRCRAFT IDENTIFIED ABOVE IS PRESENTLY AIRWORTHY AND APPROVED FOR RETURN TO SERVICE.					
Work Inspected By	<u>JASON DAYRIT</u>	Certificate No.	<u>102495</u>	Date	<u>23-Mar-2022</u>
Pertinent details of this maintenance are on file at our facility under the above Work/Service Order Number as applicable.					

Maintenance Log	
Book	Page

Maintenance Transaction Record

CAMP MTR ID # 3613270

This Maintenance Report is To Be Used Solely For (Check One)

Airframe Entries
 Eng. Serial No.
 Prop. Serial No.

Aircraft Identification and Status

A/C Serial #	A/C Registration #	Date	City ID	Total A/C Hours	Total A/C Landings	Total Engine Hrs	Total Engine Cycles	Total Prop Hrs			
208B-5098	RP-C1087	22-Mar-2022	RPLB	3883.3	6574	3883.3	6574	1558.5			

Component Changes, Inspections, Service Bulletins, or Airworthiness Directives Accomplished

Item	Transaction No.	Type	Item Name	Position	Part Number / Alternate Part	Mod Level	Part Serial	Removal Reason	Installed Part Status	TSN/TSO/TSR	Material Costs	Man Hours
------	-----------------	------	-----------	----------	------------------------------	-----------	-------------	----------------	-----------------------	-------------	----------------	-----------

5-15-02 1 2 INSPECTION DOCUMENT 02
 Comments: NO FAULT FOUND.
 IAW 208 M.M Revision 37 Dated: 1 March 2020 CH 5-15-02

Trans Type: 1 - Component, 2 - Inspection, 3 - SB, 4 - AD, -- Misc.
 Removal Reasons: WO - Worn to Limits, SC - Scheduled, UN - Unscheduled, CO - Convenience, N - Other(note in comments)
 Installed Part Status: N - New, R - Repaired / Rebuilt, S - Serviceable, O - Overhauled, T - Tested, M - Modified, I - Inspected

Repair Facility	AIRJUAN AVIATION INC.	Certified Repair Station Number	135-14	Work Order No.	S22-042
Work Performed By	GEMMY BEDRIO	Certificate No.	132926	Date	22-Mar-2022
I certify that the above stated maintenance and/or inspection was performed in accordance with the current regulations of the <input type="checkbox"/> Federal Aviation Administration <input checked="" type="checkbox"/> Other (Specify) CAAP _____ and THE AIRCRAFT IDENTIFIED ABOVE IS PRESENTLY AIRWORTHY AND APPROVED FOR RETURN TO SERVICE.					
Work Inspected By	JASON DAYRIT	Certificate No.	102495	Date	22-Mar-2022
Pertinent details of this maintenance are on file at our facility under the above Work/Service Order Number as applicable.					

Maintenance Log	
Book	Page

This Maintenance Report is To Be Used Solely For (Check One)

Airframe Entries
 Eng. Serial No.
 Prop. Serial No.

Aircraft Identification and Status

A/C Serial #	A/C Registration #	Date	City ID	Total A/C Hours	Total A/C Landings	Total Engine Hrs	Total Engine Cycles	Total Prop Hrs			
208B-5098	RP-C1087	18-Mar-2022	RPLB	3880.2	6571	3880.2	6571	1555.4			

Component Changes, Inspections, Service Bulletins, or Airworthiness Directives Accomplished

Item	Transaction No.	Type	Item Name	Position	Part Number / Alternate Part	Mod Level	Part Serial	Removal Reason	Installed Part Status	TSN/TSO/TSR	Material Costs	Man Hours
5-15-01	1	2	INSPECTION DOCUMENT 01									
Comments: NO FAULT FOUND. PERFORMED IAW 208B M.M. Revision 37 Dated: 1 March 2020 CH 5-15-01.												

Trans Type: 1 - Component, 2 - Inspection, 3 - SB, 4 - AD, -- Misc.
 Removal Reasons: WO - Worn to Limits, SC - Scheduled, UN - Unscheduled, CO - Convenience, N - Other(note in comments)
 Installed Part Status: N - New, R - Repaired / Rebuilt, S - Serviceable, O - Overhauled, T - Tested, M - Modified, I - Inspected

Repair Facility	AIR JUAN AVIATION INC.	Certified Repair Station Number	135-14	Work Order No.	S22-037
Work Performed By	EMERSON PEROCHO	Certificate No.	013397	Date	18-Mar-2022
I certify that the above stated maintenance and/or inspection was performed in accordance with the current regulations of the					
<input type="checkbox"/> Federal Aviation Administration <input checked="" type="checkbox"/> Other (Specify) CAAP and					
THE AIRCRAFT IDENTIFIED ABOVE IS PRESENTLY AIRWORTHY AND APPROVED FOR RETURN TO SERVICE.					
Work Inspected By	JASON DAYRIT	Certificate No.	102495	Date	18-Mar-2022
Pertinent details of this maintenance are on file at our facility under the above Work/Service Order Number as applicable.					

Maintenance Log	
Book	Page



Maintenance Transaction Record

CAMP MTR ID # 3612315



This Maintenance Report is To Be Used Solely For (Check One)

Airframe Entries
 Eng. Serial No.
 Prop. Serial No.

Aircraft Identification and Status

A/C Serial #	A/C Registration #	Date	City ID	Total A/C Hours	Total A/C Landings	Total Engine Hrs	Total Engine Cycles	Total Prop Hrs			
208B-5098	RP-C1087	18-Mar-2022	RPLB	3880.2	6571	3880.2	6571	1555.4			

Component Changes, Inspections, Service Bulletins, or Airworthiness Directives Accomplished

Item	Transaction No.	Type	Item Name	Position	Part Number / Alternate Part	Mod Level	Part Serial	Removal Reason	Installed Part Status	TSN/TSO/TSR	Material Costs	Man Hours
5-15-11	1	2	INSPECTION DOCUMENT 11									
Comments: NO FAULT FOUND. IAW 208B MM Revision 37 Dated: 1 March 2020 CH 5-15-11												

Trans Type: 1 - Component, 2 - Inspection, 3 - SB, 4 - AD, -- Misc.
 Removal Reasons: WO - Worn to Limits, SC - Scheduled, UN - Unscheduled, CO - Convenience, N - Other(note in comments)
 Installed Part Status: N - New, R - Repaired / Rebuilt, S - Serviceable, O - Overhauled, T - Tested, M - Modified, I - Inspected

Repair Facility	AIR JUAN AVIATION INC.	Certified Repair Station Number	135-14	Work Order No.	S22-039
Work Performed By	EMERSON PEROCHO	Certificate No.	013397	Date	18-Mar-2022
I certify that the above stated maintenance and/or inspection was performed in accordance with the current regulations of the <input type="checkbox"/> Federal Aviation Administration <input checked="" type="checkbox"/> Other (Specify) CAAP _____ and _____					
THE AIRCRAFT IDENTIFIED ABOVE IS PRESENTLY AIRWORTHY AND APPROVED FOR RETURN TO SERVICE.					
Work Inspected By	JASON DAYRIT	Certificate No.	102495	Date	18-Mar-2022
Pertinent details of this maintenance are on file at our facility under the above Work/Service Order Number as applicable.					

Maintenance Log	
Book	Page



Maintenance Transaction Record

CAMP MTR ID # 3605515



This Maintenance Report is To Be Used Solely For (Check One)

Airframe Entries
 Eng. Serial No.
 Prop. Serial No.

Aircraft Identification and Status

A/C Serial #	A/C Registration #	Date	City ID	Total A/C Hours	Total A/C Landings	Total Engine Hrs	Total Engine Cycles	Total Prop Hrs			
208B-5098	RP-C1087	14-Mar-2022	RPLB	3876.8	6568	3876.8	6568	1552			

Component Changes, Inspections, Service Bulletins, or Airworthiness Directives Accomplished

Item	Transaction No.	Type	Item Name	Position	Part Number / Alternate Part	Mod Level	Part Serial	Removal Reason	Installed Part Status	TSN/TSO/TSR	Material Costs	Man Hours
B262001	1	2	WEIGHT CHECK FORWARD FIRE EXTINGUISHER PORTABLE	FORWARD	C352TS		Y-649628					
WEIGHT CHECK Date: 14-Mar-2022 Comments: 5 lbs.												

Trans Type: 1 - Component, 2 - Inspection, 3 - SB, 4 - AD, -- Misc.
 Removal Reasons: WO - Worn to Limits, SC - Scheduled, UN - Unscheduled, CO - Convenience, N - Other(note in comments)
 Installed Part Status: N - New, R - Repaired / Rebuilt, S - Serviceable, O - Overhauled, T - Tested, M - Modified, I - Inspected

Repair Facility	AIR JUAN AVIATION INC.	Certified Repair Station Number	135-14	Work Order No.	S22-034
Work Performed By	EMERSON PEROCHO	Certificate No.	013397	Date	14-Mar-2022
I certify that the above stated maintenance and/or inspection was performed in accordance with the current regulations of the <input type="checkbox"/> Federal Aviation Administration <input checked="" type="checkbox"/> Other (Specify) CAAP and					
THE AIRCRAFT IDENTIFIED ABOVE IS PRESENTLY AIRWORTHY AND APPROVED FOR RETURN TO SERVICE.					
Work Inspected By	JASON DAYRIT	Certificate No.	102495	Date	14-Mar-2022
Pertinent details of this maintenance are on file at our facility under the above Work/Service Order Number as applicable.					

Maintenance Log	
Book	Page



Maintenance Transaction Record

CAMP MTR ID # 3578887



This Maintenance Report is To Be Used Solely For (Check One)

Airframe Entries
 Eng. Serial No.
 Prop. Serial No.

Aircraft Identification and Status

A/C Serial #	A/C Registration #	Date	City ID	Total A/C Hours	Total A/C Landings	Total Engine Hrs	Total Engine Cycles	Total Prop Hrs			
208B-5098	RP-C1087	21-Feb-2022	RPLB	3872.8	6561	3872.8	6561	1548			

Component Changes, Inspections, Service Bulletins, or Airworthiness Directives Accomplished

Item	Transaction No.	Type	Item Name	Position	Part Number / Alternate Part	Mod Level	Part Serial	Removal Reason	Installed Part Status	TSN/TSO/TSR	Material Costs	Man Hours
053401	1	2	UPDATE G1000 NAV DATA									
Comments: NEXT DUE: 24 MARCH 2022.												

Trans Type: 1 - Component, 2 - Inspection, 3 - SB, 4 - AD, -- Misc.
 Removal Reasons: WO - Worn to Limits, SC - Scheduled, UN - Unscheduled, CO - Convenience, N - Other(note in comments)
 Installed Part Status: N - New, R - Repaired / Rebuilt, S - Serviceable, O - Overhauled, T - Tested, M - Modified, I - Inspected

Repair Facility	AIR JUAN AVIATION INC.	Certified Repair Station Number	135-14	Work Order No.	S22-021
Work Performed By	EMERSON PEROCHO	Certificate No.	013397	Date	21-Feb-2022
I certify that the above stated maintenance and/or inspection was performed in accordance with the current regulations of the <input checked="" type="checkbox"/> Federal Aviation Administration <input type="checkbox"/> Other (Specify) _____ and THE AIRCRAFT IDENTIFIED ABOVE IS PRESENTLY AIRWORTHY AND APPROVED FOR RETURN TO SERVICE.					
Work Inspected By	JASON DAYRIT	Certificate No.	102495	Date	21-Feb-2022
Pertinent details of this maintenance are on file at our facility under the above Work/Service Order Number as applicable.					

Maintenance Log	
Book	Page



Maintenance Transaction Record

CAMP MTR ID # 3588327



This Maintenance Report is To Be Used Solely For (Check One)

Airframe Entries
 Eng. Serial No.
 Prop. Serial No.

Aircraft Identification and Status

A/C Serial #	A/C Registration #	Date	City ID	Total A/C Hours	Total A/C Landings	Total Engine Hrs	Total Engine Cycles	Total Prop Hrs			
208B-5098	RP-C1087	16-Feb-2022	RPLB	3872.8	6561	3872.8	6561	1548			

Component Changes, Inspections, Service Bulletins, or Airworthiness Directives Accomplished

Item	Transaction No.	Type	Item Name	Position	Part Number / Alternate Part	Mod Level	Part Serial	Removal Reason	Installed Part Status	TSN/TSO/TSR	Material Costs	Man Hours
5-15-06	1	2	INSPECTION DOCUMENT 06									
Comments: NO FAULT FOUND.												

Trans Type: 1 - Component, 2 - Inspection, 3 - SB, 4 - AD, -- Misc.
 Removal Reasons: WO - Worn to Limits, SC - Scheduled, UN - Unscheduled, CO - Convenience, N - Other(note in comments)
 Installed Part Status: N - New, R - Repaired / Rebuilt, S - Serviceable, O - Overhauled, T - Tested, M - Modified, I - Inspected

Repair Facility	AIR JUAN AVIATION INC.	Certified Repair Station Number	135-14	Work Order No.	S22-022
Work Performed By	EMERSON PEROCHO	Certificate No.	013397	Date	16-Feb-2022
I certify that the above stated maintenance and/or inspection was performed in accordance with the current regulations of the <input type="checkbox"/> Federal Aviation Administration <input checked="" type="checkbox"/> Other (Specify) CAAP _____ and _____					
THE AIRCRAFT IDENTIFIED ABOVE IS PRESENTLY AIRWORTHY AND APPROVED FOR RETURN TO SERVICE.					
Work Inspected By	JASON DAYRIT	Certificate No.	102495	Date	16-Feb-2022
Pertinent details of this maintenance are on file at our facility under the above Work/Service Order Number as applicable.					

Maintenance Log	
Book	Page

This Maintenance Report is To Be Used Solely For (Check One)

Airframe Entries
 Eng. Serial No.
 Prop. Serial No.

Aircraft Identification and Status

A/C Serial #	A/C Registration #	Date	Total A/C Hours	Total A/C Landings	Total Engine Hrs	Total Engine Cycles	Total Prop Hrs		
208B-5098	RP-C1087	03-Feb-2022	3854.6	6539	3854.6	6539	1529.8		

Component Changes, Inspections, Service Bulletins, or Airworthiness Directives Accomplished

Item	Transaction No.	Type	Item Name	Position	Part Number / Alternate Part	Mod Level	Part Serial	Removal Reason	Installed Part Status	TSN/TSO/TSR	Material Costs	Man Hours
CAL-32-04	1	3	LANDING GEAR - BRAKE CYLINDER INSPECTION, SERVICE LETTER									
MOC: COMPLIED WITH Comments: SATISFACTORY.												

Trans Type: 1 - Component, 2 - Inspection, 3 - SB, 4 - AD, -- Misc.
 Removal Reasons: WO - Worn to Limits, SC - Scheduled, UN - Unscheduled, CO - Convenience, N - Other(note in comments)
 Installed Part Status: N - New, R - Repaired / Rebuilt, S - Serviceable, O - Overhauled, T - Tested, M - Modified, I - Inspected

Repair Facility <u>AIR JUAN AVIATION INC.</u>	Certified Repair Station Number <u>135-14</u>	Work Order No. <u>S22-012</u>	
Work Performed By <u>VINCENT TERO</u>	Certificate No. <u>012697</u>	Date <u>03-Feb-2022</u>	
I certify that the above stated maintenance and/or inspection was performed in accordance with the current regulations of the <input type="checkbox"/> Federal Aviation Administration <input checked="" type="checkbox"/> Other (Specify) <u>CAAP</u> and			
THE AIRCRAFT IDENTIFIED ABOVE IS PRESENTLY AIRWORTHY AND APPROVED FOR RETURN TO SERVICE.			
Work Inspected By <u>JASON DAYRIT</u>	Certificate No. <u>102495</u>	Date <u>03-Feb-2022</u>	
Pertinent details of this maintenance are on file at our facility under the above Work/Service Order Number as applicable.			

Maintenance Log	
Book	Page

Maintenance Transaction Record

CAMP MTR ID # 3539985

This Maintenance Report is To Be Used Solely For (Check One)

Airframe Entries
 Eng. Serial No.
 Prop. Serial No.

Aircraft Identification and Status

A/C Serial #	A/C Unit #	A/C Registration #	Date	City ID	Total A/C Hours	Total A/C Landings	Total Engine Hrs	Total Engine Cycles	Total Prop Hrs			
208B-5098		RP-C1087	24-Jan-2022	RPLB	3848.2	6535	3848.2	6535	1523.4			

Component Changes, Inspections, Service Bulletins, or Airworthiness Directives Accomplished

Item	Transaction No.	Type	Item Name	Position	Part Number / Alternate Part	Mod Level	Part Serial	Removal Reason	Installed Part Status	TSN/TSO/TSR	Material Costs	Man Hours
053401	1	2	UPDATE G1000 NAV DATA									
Comments: NEXT DUE: 24 FEB 2022												
760000	2	2	NO. 1 ENGINE - DOWNLOAD ECTM									
Comments:												

Trans Type: 1 - Component, 2 - Inspection, 3 - SB, 4 - AD, -- Misc.
 Removal Reasons: WO - Worn to Limits, SC - Scheduled, UN - Unscheduled, CO - Convenience, N - Other(note in comments)
 Installed Part Status: N - New, R - Repaired / Rebuilt, S - Serviceable, O - Overhauled, T - Tested, M - Modified, I - Inspected

Repair Facility	AIR JUAN AVIATION INC.	Certified Repair Station Number	135-14	Work Order No.	S22-008
Work Performed By	EMERSON PEROCHO	Certificate No.	013397	Date	24-Jan-2022
I certify that the above stated maintenance and/or inspection was performed in accordance with the current regulations of the <input type="checkbox"/> Federal Aviation Administration <input checked="" type="checkbox"/> Other (Specify) CAAP and					
THE AIRCRAFT IDENTIFIED ABOVE IS PRESENTLY AIRWORTHY AND APPROVED FOR RETURN TO SERVICE.					
Work Inspected By	JASON DAYRIT	Certificate No.	102495	Date	24-Jan-2022
Pertinent details of this maintenance are on file at our facility under the above Work/Service Order Number as applicable.					

Maintenance Log	
Book	Page



Maintenance Transaction Record

CAMP MTR ID # 3532329



This Maintenance Report is To Be Used Solely For (Check One)

Airframe Entries Eng. Serial No. Prop. Serial No.

Aircraft Identification and Status

A/C Serial #	A/C Unit #	A/C Registration #	Date	City ID	Total A/C Hours	Total A/C Landings	Total Engine Hrs	Total Engine Cycles	Total Prop Hrs			
208B-5098		RP-C1087	15-Jan-2022	RPLB	3841.8	6530	3841.8	6530	1517			

Component Changes, Inspections, Service Bulletins, or Airworthiness Directives Accomplished

Item	Transaction No.	Type	Item Name	Position	Part Number / Alternate Part	Mod Level	Part Serial	Removal Reason	Installed Part Status	TSN/TSO/TSR	Material Costs	Man Hours
------	-----------------	------	-----------	----------	------------------------------	-----------	-------------	----------------	-----------------------	-------------	----------------	-----------

5-15-08 1 2 INSPECTION DOCUMENT 08

Comments:

Trans Type: 1 - Component, 2 - Inspection, 3 - SB, 4 - AD, -- Misc. Removal Reasons: WO - Worn to Limits, SC - Scheduled, UN - Unscheduled, CO - Convenience, N - Other(note in comments) Installed Part Status: N - New, R - Repaired / Rebuilt, S - Serviceable, O - Overhauled, T - Tested, M - Modified, I - Inspected

Repair Facility	<u>AIR JUAN AVIATION INC.</u>	Certified Repair Station Number	<u>135-14</u>	Work Order No.	<u>S22-006</u>
Work Performed By	<u>EMERSON PEROCHO</u>	Certificate No.	<u>013397</u>	Date	<u>15-Jan-2022</u>
<p>I certify that the above stated maintenance and/or inspection was performed in accordance with the current regulations of the</p> <p><input type="checkbox"/> Federal Aviation Administration <input checked="" type="checkbox"/> Other (Specify) <u>CAAP</u> and</p> <p>THE AIRCRAFT IDENTIFIED ABOVE IS PRESENTLY AIRWORTHY AND APPROVED FOR RETURN TO SERVICE.</p>					
Work Inspected By	<u>JASON DAYRIT</u>	Certificate No.	<u>102495</u>	Date	<u>15-Jan-2022</u>
<p>Pertinent details of this maintenance are on file at our facility under the above Work/Service Order Number as applicable.</p>					

Maintenance Log	
Book	Page



Maintenance Transaction Record

CAMP MTR ID # 3529015



This Maintenance Report is To Be Used Solely For (Check One)

Airframe Entries
 Eng. Serial No.
 Prop. Serial No.

Aircraft Identification and Status

A/C Serial #	A/C Unit #	A/C Registration #	Date	City ID	Total A/C Hours	Total A/C Landings	Total Engine Hrs	Total Engine Cycles	Total Prop Hrs			
208B-5098		RP-C1087	10-Jan-2022		3841.8	6530	3841.8	6530	1517			

Component Changes, Inspections, Service Bulletins, or Airworthiness Directives Accomplished

Item	Transaction No.	Type	Item Name	Position	Part Number / Alternate Part	Mod Level	Part Serial	Removal Reason	Installed Part Status	TSN/TSO/TSR	Material Costs	Man Hours
053401	1	2	UPDATE G1000 NAV DATA									
Comments:												

Trans Type: 1 - Component, 2 - Inspection, 3 - SB, 4 - AD, -- Misc.
 Removal Reasons: WO - Worn to Limits, SC - Scheduled, UN - Unscheduled, CO - Convenience, N - Other (note in comments)
 Installed Part Status: N - New, R - Repaired / Rebuilt, S - Serviceable, O - Overhauled, T - Tested, M - Modified, I - Inspected

Repair Facility	AIR JUAN AVIATION INC.	Certified Repair Station Number	135-14	Work Order No.	S22-002
Work Performed By	EMERSON PEROCHO	Certificate No.	013397	Date	10-Jan-2022
I certify that the above stated maintenance and/or inspection was performed in accordance with the current regulations of the <input type="checkbox"/> Federal Aviation Administration <input checked="" type="checkbox"/> Other (Specify) CAAP and					
THE AIRCRAFT IDENTIFIED ABOVE IS PRESENTLY AIRWORTHY AND APPROVED FOR RETURN TO SERVICE.					
Work Inspected By	JASON DAYRIT	Certificate No.	102495	Date	10-Jan-2022
Pertinent details of this maintenance are on file at our facility under the above Work/Service Order Number as applicable.					

Maintenance Log	
Book	Page

Maintenance Transaction Record

CAMP MTR ID # 3441947

This Maintenance Report is To Be Used Solely For (Check One)

Airframe Entries
 Eng. Serial No.
 Prop. Serial No.

Aircraft Identification and Status

A/C Serial #	A/C Unit #	A/C Registration #	Date	City ID	Total A/C Hours	Total A/C Landings	Total Engine Hrs	Total Engine Cycles	Total Prop Hrs			
208B-5098		RP-C1087	15-Nov-2021	RPLB	3798.6	6473	3798.6	6473	1473.8			

Component Changes, Inspections, Service Bulletins, or Airworthiness Directives Accomplished

Item	Transaction No.	Type	Item Name	Position	Part Number / Alternate Part	Mod Level	Part Serial	Removal Reason	Installed Part Status	TSN/TSO/TSR	Material Costs	Man Hours
B345001	1	2	CALIBRATION TEST NO. 2 TRANSPONDER NO. 2 (FAR 91.413) CALIBRATION Date: 15-Nov-2021 Comments: NEXT DUE: 15 NOV 2022		011-00779-10		89127200					
B345001	2	2	CALIBRATION TEST NO. 1 TRANSPONDER NO. 1 (FAR 91.413) CALIBRATION Date: 15-Nov-2021 Comments: NEXT DUE: 15 NOV 2022		011-00779-10		89128030					
5-15-20	3	2	INSPECTION DOCUMENT 20 Comments: NEXT DUE: 15 NOV 2022									

Trans Type: 1 - Component, 2 - Inspection, 3 - SB, 4 - AD, -- Misc.
 Removal Reasons: WO - Worn to Limits, SC - Scheduled, UN - Unscheduled, CO - Convenience, N - Other(note in comments)
 Installed Part Status: N - New, R - Repaired / Rebuilt, S - Serviceable, O - Overhauled, T - Tested, M - Modified, I - Inspected

Repair Facility	AIR JUAN AVIATION INC.	Certified Repair Station Number	135-14	Work Order No.	S21-124
Work Performed By	EMERSON PEROCHO	Certificate No.	013397	Date	15-Nov-2021
I certify that the above stated maintenance and/or inspection was performed in accordance with the current regulations of the <input type="checkbox"/> Federal Aviation Administration <input checked="" type="checkbox"/> Other (Specify) CAAP and					
THE AIRCRAFT IDENTIFIED ABOVE IS PRESENTLY AIRWORTHY AND APPROVED FOR RETURN TO SERVICE.					
Work Inspected By	JASON DAYRIT	Certificate No.	102495	Date	15-Nov-2021
Pertinent details of this maintenance are on file at our facility under the above Work/Service Order Number as applicable.					

Maintenance Log	
Book	Page



Aviation Support International Inc.

PHILAIR HANGAR, Manila Domestic Airport, Pasay City Telefax: (632)8339432

CAAP AMO CERTIFICATE NO. 04-82

Customer: AIR JUAN AVIATION INC.	Service Order No.: 2021-1115-86	Ref. No: ASII-0021-65
A/C Type: CESSNA GRAND CARAVAN EX	A/C Registry No.: RP-C1087	A/C Serial No.: 208B5098

A. Performed Transponder System Check/Inspection Required by CAAP PCAR 8-8.2.8.1.7, FAR 91.413

DESCRIPTION	SERIAL NUMBER
GARMIN GTX 33	89128030
GARMIN GTX 33	89127200

- Functionally Test Satisfactory. Unit is **SERVICEABLE**
- Next Due Date: **November 15, 2022**

B. Performed ELT Check as required by CAAP Part 8-8.2.1.7 (a)

DESCRIPTION	SERIAL NUMBER	BATTERY EXPIRATION
C406-N	14616	SEPT/2024

- Functionally Test Satisfactory. Unit is **SERVICEABLE**
- Next Due Date: **November 15, 2022**

I hereby certify that the items described above was performed, repaired and inspected in accordance with the current maintenance rules of Civil Aviation Regulations and it is approved for return to service. For and in behalf of Aviation Support International Inc. AMO Certificate No. 04-82. Test reports and/or data are on file.

Name:

Signature:

Date:

Wilfredo L. Rago

November 15, 2021

For and on behalf of Aviation Support Intl. Inc.

This Maintenance Report is To Be Used Solely For (Check One)

Airframe Entries
 Eng. Serial No.
 Prop. Serial No.

Aircraft Identification and Status

A/C Serial #	A/C Unit #	A/C Registration #	Date	City ID	Total A/C Hours	Total A/C Landings	Total Engine Hrs	Total Engine Cycles	Total Prop Hrs			
208B-5098		RP-C1087	29-Oct-2021	RPLB	3798.6	6473	3798.6	6473	1473.8			

Component Changes, Inspections, Service Bulletins, or Airworthiness Directives Accomplished

Item	Transaction No.	Type	Item Name	Position	Part Number / Alternate Part	Mod Level	Part Serial	Removal Reason	Installed Part Status	TSN/TSO/TSR	Material Costs	Man Hours
053401	1	2	UPDATE G1000 NAV DATA									
Comments:												
760000	2	2	NO. 1 ENGINE - DOWNLOAD ECTM									
Comments:												

Trans Type: 1 - Component, 2 - Inspection, 3 - SB, 4 - AD, -- Misc.
 Removal Reasons: WO - Worn to Limits, SC - Scheduled, UN - Unscheduled, CO - Convenience, N - Other(note in comments)
 Installed Part Status: N - New, R - Repaired / Rebuilt, S - Serviceable, O - Overhauled, T - Tested, M - Modified, I - Inspected

Repair Facility <u>AIR JUAN AVIATION INC.</u>	Certified Repair Station Number <u>135-14</u>	Work Order No. <u>S21-120</u>	
Work Performed By <u>EMERSON PEROCHO</u>	Certificate No. <u>013397</u>	Date <u>29-Oct-2021</u>	
I certify that the above stated maintenance and/or inspection was performed in accordance with the current regulations of the <input type="checkbox"/> Federal Aviation Administration <input checked="" type="checkbox"/> Other (Specify) <u>CAAP</u> and			
THE AIRCRAFT IDENTIFIED ABOVE IS PRESENTLY AIRWORTHY AND APPROVED FOR RETURN TO SERVICE.			
Work Inspected By <u>JASON DAYRIT</u>	Certificate No. <u>102495</u>	Date <u>29-Oct-2021</u>	
Pertinent details of this maintenance are on file at our facility under the above Work/Service Order Number as applicable.			

Maintenance Log	
Book	Page

This Maintenance Report is To Be Used Solely For (Check One)

Airframe Entries
 Eng. Serial No.
 Prop. Serial No.

Aircraft Identification and Status

A/C Serial #	A/C Unit #	A/C Registration #	Date	City ID	Total A/C Hours	Total A/C Landings	Total Engine Hrs	Total Engine Cycles	Total Prop Hrs			
208B-5098		RP-C1087	02-Oct-2021	RPLB	3798.6	6473	3798.6	6473	1473.8			

Component Changes, Inspections, Service Bulletins, or Airworthiness Directives Accomplished

Item	Transaction No.	Type	Item Name	Position	Part Number / Alternate Part	Mod Level	Part Serial	Removal Reason	Installed Part Status	TSN/TSO/TSR	Material Costs	Man Hours
053401	1	2	UPDATE G1000 NAV DATA									
Comments:												

Trans Type: 1 - Component, 2 - Inspection, 3 - SB, 4 - AD, -- Misc.
 Removal Reasons: WO - Worn to Limits, SC - Scheduled, UN - Unscheduled, CO - Convenience, N - Other(note in comments)
 Installed Part Status: N - New, R - Repaired / Rebuilt, S - Serviceable, O - Overhauled, T - Tested, M - Modified, I - Inspected

Repair Facility <u>AIR JUAN AVIATION INC.</u>	Certified Repair Station Number <u>135-14</u>	Work Order No. <u>S21-104</u>	
Work Performed By <u>EMERSON PEROCHO</u>	Certificate No. <u>013397</u>	Date <u>02-Oct-2021</u>	
I certify that the above stated maintenance and/or inspection was performed in accordance with the current regulations of the			
<input type="checkbox"/> Federal Aviation Administration <input checked="" type="checkbox"/> Other (Specify) <u>CAAP</u> and			
THE AIRCRAFT IDENTIFIED ABOVE IS PRESENTLY AIRWORTHY AND APPROVED FOR RETURN TO SERVICE.			
Work Inspected By <u>JASON DAYRIT</u>	Certificate No. <u>102495</u>	Date <u>02-Oct-2021</u>	
Pertinent details of this maintenance are on file at our facility under the above Work/Service Order Number as applicable.			

Maintenance Log	
Book	Page

AIRCRAFT WEIGHT AND BALANCE REPORT

CLIENT: AIR JUAN AVIATION, INC.	AIRCRAFT MSN: 20885098
AIRCRAFT MAKE & MODEL: TEXTRON AVIATION INC. / CESSNA GRAND CARAVAN EX 208B	WORK ORDER NO: AHA121-W&B-0003
AIRCRAFT REGISTRATION NO: RP-C1087	WEIGHED BY: CHRISTOPHER RYAN C. SANTIAGO
DATE WEIGHED: September 15, 2021	PLACE WEIGHED: SUBIC BAY INTERNATIONAL AIRPORT

REACTION	SCALE READINGS (lbs)	TARE (lbs)	Net Weight (lbs)	ARM (in.)	MOMENT (lbs-in.)
LEFT MAIN	2,072.50	0.00	2,072.50	XXXXXXXXXX	XXXXXXXXXX
RIGHT MAIN	2,236.00	0.00	2,236.00		
SUB-TOTAL MAIN	4,308.50	0.00	4,308.50		
NOSE/REAR	864.00	0.00	864.00	-41.00	-35,424.00
TOTAL WEIGHT (AS WEIGHED)	5,172.50	0.00	5,172.50	189.94	465,223.70

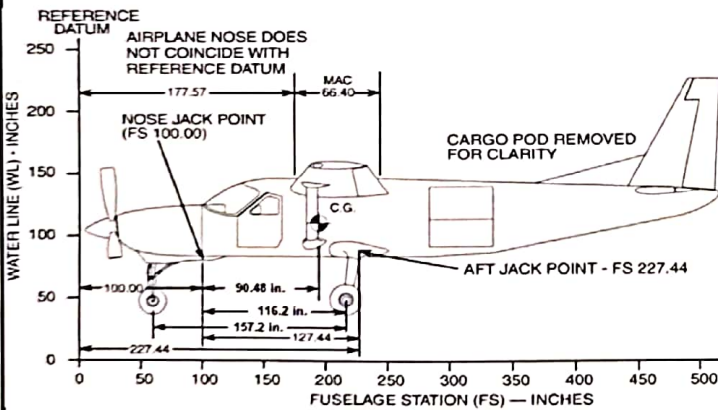

REMARKS:

- Aircraft was weighed in level flight position using W/S AWS-9k-REM platform scales.
- Aircraft condition when weighed:
 - Clean
 - Fuel tanks are empty
 - Oil is in operational quantity, 29 lbs.
 - 13 Life vests installed on aircraft
 - Additional two single seats in most aft row. (Refer to the CAAP Approved Letter dated January 25, 2018).
- Weight and tare reading is the average of two (2) trial readings.
C.G. at basic empty weight 5196.60 (lbs) = 190.48 in. from RDL.
- References:
 - Cessna Model 208B POH (Weight and Balance Section)
 - Maintenance Manual (Leveling and Weighing Chapter)
 - TCDS A37CE Rev. 22 October 31, 2017
 - Previous Weight and Balance Report
 - Equipment List
- Tools List:
 - Spirit Levels
 - Tape Measure
 - Chalk Line
 - Plumb Bob
- Reference Datum during weighing is nose jacking point/front end firewall. Final C.G. Arm is computed C.G. Arm plus 100 in.:
C.G. = 90.48184 in. + 100 in. = 190.48184 in.

ITEMS	NET WEIGHT (lbs)	ARM (in.)	MOMENT (lbs-in.)
TOTAL WEIGHT (AS WEIGHED)	5,172.50	189.94	465,223.70
TOTAL ITEMS WEIGHED BUT NOT PART OF BASIC WT. (-) (DETAILS PAGE 2, ITEM A)	0.00	0.00	0.00
TOTAL ITEMS WEIGHT NOT IN AIRCRAFT WHEN WEIGHED (+) (DETAILS PAGE 2, ITEM B)	24.10	206.40	4,974.24
BASIC EMPTY WEIGHT	5,196.60	190.48	470,197.94

WEIGHED BY:

CHRISTOPHER RYAN C. SANTIAGO
A&P LICENSE NO. 122882
PRINTED NAME & SIGNATURE

AHA1 Authorized Weighing Personnel
POSITION

15-Sep-21
DATE

CERTIFIED CORRECT BY:

ENGR. MAT JONEL D. BONDOC
PRC LICENSE NO. 0001804
PRINTED NAME & SIGNATURE

Aeronautical Engineer
POSITION

15-Sep-21
DATE



Hangar 3, OMNI
Aviation Complex, M.A.
Roxas Highway,
Clarkfield, CFZ,
Pampanga, Philippines,
2009

CAAP AMO Cert No: 151
16

ENGINEERING
DEPARTMENT

Control No:
2021-09-W&B-01018

REV DATE: 30-Oct-20

REV NO: 1

AIRCRAFT WEIGHT AND BALANCE REPORT

ITEM A: ITEMS WEIGHED BUT NOT PART OF BASIC WEIGHT	NET WEIGHT (lbs)	ARM (in.)	MOMENT (lbs-in.)
No Items Weighed	0.00	0.00	0.00
TOTAL	0.00	0.00	0.00
ITEM B: ITEMS WEIGHT NOT IN THE AIRCRAFT WHEN WEIGHED	NET WEIGHT (lbs)	ARM (in.)	MOMENT (lbs-in.)
Unusable Fuel	24.10	206.40	4974.24
TOTAL	24.10	206.40	4974.24



Hangar 3, OMNI
Aviation Complex, M.A.
Roxas Highway,
Clarkfield, CFZ,
Pampanga, Philippines,
2009

ENGINEERING
DEPARTMENT

Control No:
2021-09-W&B-01018

REV DATE: 30-Oct-20

REV NO: 1

CAAP AMO Cert No:
151-16

AIRCRAFT WEIGHT AND BALANCE REPORT

CLIENT: AIR JUAN AVIATION, INC.	AIRCRAFT MSN: 208B5098
AIRCRAFT MAKE & MODEL: TEXTRON AVIATION INC. / CESSNA GRAND CARAVAN EX 208B	WORK ORDER NO: AHAI21-W&B-0003
AIRCRAFT REGISTRATION NO: RP-C1087	WEIGHED BY: CHRISTOPHER RYAN C. SANTIAGO
DATE WEIGHED: September 15, 2021	PLACE WEIGHED: SUBIC BAY INTERNATIONAL AIRPORT

	1st Reading	2nd Reading	3rd Reading	Average
Left Main	2069	2076	-	2072.50
Right Main	2237	2235	-	2236.00
Sub-total Main	4,306	4,311	-	4308.50
Nose/Rear	862	866	-	864.00
Total Weight	5,168	5,177	-	5172.50

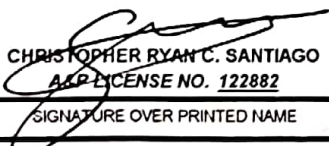
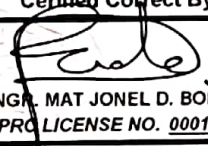
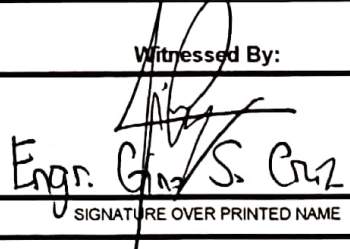
Weighed By:	Certified Correct By:	Witnessed By:
		
CHRISTOPHER RYAN C. SANTIAGO CAAP LICENSE NO. 122882	ENGR. MAT JONEL D. BONDOC PRO LICENSE NO. 0001804	Engr. Gino S. Cruz
SIGNATURE OVER PRINTED NAME	SIGNATURE OVER PRINTED NAME	SIGNATURE OVER PRINTED NAME
AHAI Authorized Weighing Personnel	Aeronautical Engineer	CAAP Inspector

AIRCRAFT WEIGHT & BALANCE CHECKLIST

INSTRUCTIONS : Print or type all entries

1. AIRCRAFT	Make	Model/Type
	TEXTRON AVIATION INC.	CESSNA GRAND CARAVAN EX 208B
	Serial Number	Nationality and Registration Mark
	208B5098	RP-C1087
2. OWNER	Name (As shown on the Registration Certificate)	
	AIR JUAN AVIATION, INC.	
	Address (As shown on the Registration Certificate)	
	SUBIC BAY INTERNATIONAL AIRPORT	

Nomenclature	Quantity	Condition	Checked By	Weighing Engineer	Remarks
1. Fuel	EMPTY	EMPTY	<i>[Signature]</i>	<i>[Signature]</i>	SATISFACTORY
2. Oil	FULL	OPERATIONAL QUANTITY	<i>[Signature]</i>	<i>[Signature]</i>	SATISFACTORY
3. Safety Devices			<i>[Signature]</i>	<i>[Signature]</i>	
a. Fire Extinguisher	1EA	SERVICEABLE	<i>[Signature]</i>	<i>[Signature]</i>	SATISFACTORY
b. Medical Kit	1EA	SERVICEABLE	<i>[Signature]</i>	<i>[Signature]</i>	SATISFACTORY
c. ELT	1EA	INSTALLED/SERVICEABLE	<i>[Signature]</i>	<i>[Signature]</i>	SATISFACTORY
d. Life Vest	13EA	SERVICEABLE	<i>[Signature]</i>	<i>[Signature]</i>	SATISFACTORY
4. Passenger Seats with Safety Belts	13EA	AIRWORTHY	<i>[Signature]</i>	<i>[Signature]</i>	SATISFACTORY
5. Battery	1EA	INSTALLED/SERVICEABLE	<i>[Signature]</i>	<i>[Signature]</i>	SATISFACTORY
6. Avionics Equipment	COMPLETE	AIRWORTHY	<i>[Signature]</i>	<i>[Signature]</i>	SATISFACTORY
7. Trims :			<i>[Signature]</i>	<i>[Signature]</i>	
a. Side Panels	COMPLETE	GOOD CONDITION	<i>[Signature]</i>	<i>[Signature]</i>	SATISFACTORY
b. Carpet	COMPLETE	GOOD CONDITION	<i>[Signature]</i>	<i>[Signature]</i>	SATISFACTORY
c. Windows	COMPLETE	GOOD CONDITION	<i>[Signature]</i>	<i>[Signature]</i>	SATISFACTORY
8. Control Surfaces	COMPLETE	AIRWORTHY	<i>[Signature]</i>	<i>[Signature]</i>	SATISFACTORY
9. Flaps	COMPLETE	AIRWORTHY	<i>[Signature]</i>	<i>[Signature]</i>	SATISFACTORY
10. Aircraft	COMPLETE	CLEAN AND WELL MAINTAIN	<i>[Signature]</i>	<i>[Signature]</i>	SATISFACTORY

Prepared By : *[Signature]*
 ENGR. MAT JONEL D. BONDOC
 PRO LICENSE NO. 0001804
 Aeronautical Engineer

Verified Correct By : *[Signature]*
 ARIEL JASON DAYRIT
 102995- AMT/AMS
 Customer Representative

This Maintenance Report is To Be Used Solely For (Check One)

Airframe Entries
 Eng. Serial No.
 Prop. Serial No.

Aircraft Identification and Status

A/C Serial #	A/C Unit #	A/C Registration #	Date	City ID	Total A/C Hours	Total A/C Landings	Total Engine Hrs	Total Engine Cycles	Total Prop Hrs			
208B-5098		RP-C1087	04-Sep-2021	RPLB	3795.5	6470	3795.5	6470	1470.7			

Component Changes, Inspections, Service Bulletins, or Airworthiness Directives Accomplished

Item	Transaction No.	Type	Item Name	Position	Part Number / Alternate Part	Mod Level	Part Serial	Removal Reason	Installed Part Status	TSN/TSO/TSR	Material Costs	Man Hours
053401	1	2	UPDATE G1000 NAV DATA									
Comments:												
760000	2	2	NO. 1 ENGINE - DOWNLOAD ECTM									
Comments:												
792020	3	1	OIL COOLER CHECK VALVE (CHECK VALVE ASSEMBLY REPAIR) RESTORATION (AIRPLANES208B-2197, AND 208B5000 AND ON)		PN		UNK	N	N	0 HRS		
Comments: OPTIONAL UNDER CAL-79-01												

Trans Type: 1 - Component, 2 - Inspection, 3 - SB, 4 - AD, -- Misc.
 Removal Reasons: WO - Worn to Limits, SC - Scheduled, UN - Unscheduled, CO - Convenience, N - Other(note in comments)
 Installed Part Status: N - New, R - Repaired / Rebuilt, S - Serviceable, O - Overhauled, T - Tested, M - Modified, I - Inspected

Repair Facility AIR JUAN AVIATION INC.	Certified Repair Station Number 135-14	Work Order No. S21-092	
Work Performed By EMERSON PEROCHO	Certificate No. 013397	Date 04-Sep-2021	
I certify that the above stated maintenance and/or inspection was performed in accordance with the current regulations of the <input type="checkbox"/> Federal Aviation Administration <input checked="" type="checkbox"/> Other (Specify) CAAP and			
THE AIRCRAFT IDENTIFIED ABOVE IS PRESENTLY AIRWORTHY AND APPROVED FOR RETURN TO SERVICE.			
Work Inspected By JASON DAYRIT	Certificate No. 102495	Date 04-Sep-2021	
Pertinent details of this maintenance are on file at our facility under the above Work/Service Order Number as applicable.			

Maintenance Log	
Book	Page



Maintenance Transaction Record

CAMP MTR ID # 3303208



This Maintenance Report is To Be Used Solely For (Check One)

Airframe Entries
 Eng. Serial No.
 Prop. Serial No.

Aircraft Identification and Status

A/C Serial #	A/C Unit #	A/C Registration #	Date	City ID	Total A/C Hours	Total A/C Landings	Total Engine Hrs	Total Engine Cycles	Total Prop Hrs			
208B-5098		RP-C1087	07-Aug-2021		3795.5	6470	3795.5	6470	1470.7			

Component Changes, Inspections, Service Bulletins, or Airworthiness Directives Accomplished

Item	Transaction No.	Type	Item Name	Position	Part Number / Alternate Part	Mod Level	Part Serial	Removal Reason	Installed Part Status	TSN/TSO/TSR	Material Costs	Man Hours
053401	1	2	UPDATE G1000 NAV DATA Comments: NEXY UPDATE; 9-SEP-21 CYCLE 2108									
760000	2	2	NO. 1 ENGINE - DOWNLOAD ECTM Comments:									

Trans Type: 1 - Component, 2 - Inspection, 3 - SB, 4 - AD, -- Misc.
 Removal Reasons: WO - Worn to Limits, SC - Scheduled, UN - Unscheduled, CO - Convenience, N - Other(note in comments)
 Installed Part Status: N - New, R - Repaired / Rebuilt, S - Serviceable, O - Overhauled, T - Tested, M - Modified, I - Inspected

Repair Facility	AIR JUAN AVIATION INC.	Certified Repair Station Number	135-14	Work Order No.	S21-078
Work Performed By	EMERSON PEROCHO	Certificate No.	013397	Date	07-Aug-2021
I certify that the above stated maintenance and/or inspection was performed in accordance with the current regulations of the <input type="checkbox"/> Federal Aviation Administration <input checked="" type="checkbox"/> Other (Specify) CAAP and THE AIRCRAFT IDENTIFIED ABOVE IS PRESENTLY AIRWORTHY AND APPROVED FOR RETURN TO SERVICE.					
Work Inspected By	JASON DAYRIT	Certificate No.	102495	Date	07-Aug-2021
Pertinent details of this maintenance are on file at our facility under the above Work/Service Order Number as applicable.					

Maintenance Log	
Book	Page



Maintenance Transaction Record

CAMP MTR ID # 3287261



This Maintenance Report is To Be Used Solely For (Check One)

Airframe Entries
 Eng. Serial No.
 Prop. Serial No.

Aircraft Identification and Status

A/C Serial #	A/C Unit #	A/C Registration #	Date	City ID	Total A/C Hours	Total A/C Landings	Total Engine Hrs	Total Engine Cycles	Total Prop Hrs			
208B-5098		RP-C1087	12-Jul-2021	RPLB	3790	6464	3790	6464	1465.2			

Component Changes, Inspections, Service Bulletins, or Airworthiness Directives Accomplished

Item	Transaction No.	Type	Item Name	Position	Part Number / Alternate Part	Mod Level	Part Serial	Removal Reason	Installed Part Status	TSN/TSO/TSR	Material Costs	Man Hours
053401	1	2	UPDATE G1000 NAV DATA									
Comments:												

Trans Type: 1 - Component, 2 - Inspection, 3 - SB, 4 - AD, -- Misc.
 Removal Reasons: WO - Worn to Limits, SC - Scheduled, UN - Unscheduled, CO - Convenience, N - Other(note in comments)
 Installed Part Status: N - New, R - Repaired / Rebuilt, S - Serviceable, O - Overhauled, T - Tested, M - Modified, I - Inspected

Repair Facility	AIR JUAN AVIATION INC.	Certified Repair Station Number	135-14	Work Order No.	S21-060
Work Performed By	EMERSON PEROCHO	Certificate No.	013397	Date	12-Jul-2021
I certify that the above stated maintenance and/or inspection was performed in accordance with the current regulations of the <input type="checkbox"/> Federal Aviation Administration <input checked="" type="checkbox"/> Other (Specify) CAAP and					
THE AIRCRAFT IDENTIFIED ABOVE IS PRESENTLY AIRWORTHY AND APPROVED FOR RETURN TO SERVICE.					
Work Inspected By	JASON DAYRIT	Certificate No.	102495	Date	12-Jul-2021
Pertinent details of this maintenance are on file at our facility under the above Work/Service Order Number as applicable.					

Maintenance Log	
Book	Page

Maintenance Transaction Record

CAMP MTR ID # 3279322

This Maintenance Report is To Be Used Solely For (Check One)

Airframe Entries
 Eng. Serial No.
 Prop. Serial No.

Aircraft Identification and Status

A/C Serial #	A/C Unit #	A/C Registration #	Date	City ID	Total A/C Hours	Total A/C Landings	Total Engine Hrs	Total Engine Cycles	Total Prop Hrs			
208B-5098		RP-C1087	23-Jun-2021	RPLB	3790	6464	3790	6464	1465.2			

Component Changes, Inspections, Service Bulletins, or Airworthiness Directives Accomplished

Item	Transaction No.	Type	Item Name	Position	Part Number / Alternate Part	Mod Level	Part Serial	Removal Reason	Status	Installed Part TSN/TSO/TSR	Material Costs	Man Hours
370102	1	1	VACUUM SYSTEM CENTRAL AIR FILTER DISCARD		AAD-9-18-1		NSN	N	N	0 MTH 0 HRS		
Comments: Removed part no: AAD-9-18-1 Removed serial no: NSN.												
370103	2	1	VACUUM RELIEF VALVE FILTER DISCARD		C482001-0202		NSN	N	N	0 MTH 0 HRS		
Comments: Removed part no: C482001-0202 Removed serial no: NSN.												
760000	3	2	NO. 1 ENGINE - DOWNLOAD ECTM									
Comments:												

Trans Type: 1 - Component, 2 - Inspection, 3 - SB, 4 - AD, -- Misc.
 Removal Reasons: WO - Worn to Limits, SC - Scheduled, UN - Unscheduled, CO - Convenience, N - Other(note in comments)
 Installed Part Status: N - New, R - Repaired / Rebuilt, S - Serviceable, O - Overhauled, T - Tested, M - Modified, I - Inspected

Repair Facility	SUBIC	Certified Repair Station Number	135-14	Work Order No.	S21-048
Work Performed By	VINCENT TERO	Certificate No.	012697-AMT	Date	23-Jun-2021
I certify that the above stated maintenance and/or inspection was performed in accordance with the current regulations of the <input type="checkbox"/> Federal Aviation Administration <input checked="" type="checkbox"/> Other (Specify) CAAP and					
THE AIRCRAFT IDENTIFIED ABOVE IS PRESENTLY AIRWORTHY AND APPROVED FOR RETURN TO SERVICE.					
Work Inspected By	JASON DAYRIT	Certificate No.	102495	Date	23-Jun-2021
Pertinent details of this maintenance are on file at our facility under the above Work/Service Order Number as applicable.					

Maintenance Log	
Book	Page



Maintenance Transaction Record

CAMP MTR ID # 3280405



This Maintenance Report is To Be Used Solely For (Check One)

Airframe Entries
 Eng. Serial No.
 Prop. Serial No.

Aircraft Identification and Status

A/C Serial #	A/C Unit #	A/C Registration #	Date	City ID	Total A/C Hours	Total A/C Landings	Total Engine Hrs	Total Engine Cycles	Total Prop Hrs			
208B-5098		RP-C1087	27-Jun-2021	RPLB	3790	6464	3790	6464	1465.2			

Component Changes, Inspections, Service Bulletins, or Airworthiness Directives Accomplished

Item	Transaction No.	Type	Item Name	Position	Part Number / Alternate Part	Mod Level	Part Serial	Removal Reason	Installed Part Status	TSN/TSO/TSR	Material Costs	Man Hours
240501A	1	2	CAPACITY CHECK BATTERY (GILL OR CONCORD BATTERY)		RG380E/40B		41114653					
Comments:												

Trans Type: 1 - Component, 2 - Inspection, 3 - SB, 4 - AD, -- Misc.
 Removal Reasons: WO - Worn to Limits, SC - Scheduled, UN - Unscheduled, CO - Convenience, N - Other(note in comments)
 Installed Part Status: N - New, R - Repaired / Rebuilt, S - Serviceable, O - Overhauled, T - Tested, M - Modified, I - Inspected

Repair Facility	SUBIC	Certified Repair Station Number	135-14	Work Order No.	S21-049
Work Performed By	EMERSON PEROCHO	Certificate No.	013397	Date	27-Jun-2021
I certify that the above stated maintenance and/or inspection was performed in accordance with the current regulations of the <input type="checkbox"/> Federal Aviation Administration <input checked="" type="checkbox"/> Other (Specify) CAAP and					
THE AIRCRAFT IDENTIFIED ABOVE IS PRESENTLY AIRWORTHY AND APPROVED FOR RETURN TO SERVICE.					
Work Inspected By	JASON DAYRIT	Certificate No.	102495	Date	27-Jun-2021
Pertinent details of this maintenance are on file at our facility under the above Work/Service Order Number as applicable.					

Maintenance Log	
Book	Page



Maintenance Transaction Record

CAMP MTR ID # 3274058



This Maintenance Report is To Be Used Solely For (Check One)

Airframe Entries
 Eng. Serial No.
 Prop. Serial No.

Aircraft Identification and Status

A/C Serial #	A/C Unit #	A/C Registration #	Date	City ID	Total A/C Hours	Total A/C Landings	Total Engine Hrs	Total Engine Cycles	Total Prop Hrs			
208B-5098		RP-C1087	13-Jun-2021	RPLB	3790	6464	3790	6464	1465.2			

Component Changes, Inspections, Service Bulletins, or Airworthiness Directives Accomplished

Item	Transaction No.	Type	Item Name	Position	Part Number / Alternate Part	Mod Level	Part Serial	Removal Reason	Installed Part Status	TSN/TSO/TSR	Material Costs	Man Hours
CAL-24-05	1	3	ELECTRICAL POWER - WIRE BUNDLE ID TAG INSPECTION, SERVICE LETTER									
MOC: COMPLIED WITH Comments:												

Trans Type: 1 - Component, 2 - Inspection, 3 - SB, 4 - AD, -- Misc.
 Removal Reasons: WO - Worn to Limits, SC - Scheduled, UN - Unscheduled, CO - Convenience, N - Other(note in comments)
 Installed Part Status: N - New, R - Repaired / Rebuilt, S - Serviceable, O - Overhauled, T - Tested, M - Modified, I - Inspected

Repair Facility	SUBIC	Certified Repair Station Number	135-14	Work Order No.	S21-045
Work Performed By	EMERSON PEROCHO	Certificate No.	013397	Date	13-Jun-2021
I certify that the above stated maintenance and/or inspection was performed in accordance with the current regulations of the <input type="checkbox"/> Federal Aviation Administration <input checked="" type="checkbox"/> Other (Specify) CAAP and					
THE AIRCRAFT IDENTIFIED ABOVE IS PRESENTLY AIRWORTHY AND APPROVED FOR RETURN TO SERVICE.					
Work Inspected By	JASON DAYRIT	Certificate No.	102495	Date	13-Jun-2021
Pertinent details of this maintenance are on file at our facility under the above Work/Service Order Number as applicable.					

Maintenance Log	
Book	Page



Maintenance Transaction Record

CAMP MTR ID # 3274006



This Maintenance Report is To Be Used Solely For (Check One)

Airframe Entries
 Eng. Serial No.
 Prop. Serial No.

Aircraft Identification and Status

A/C Serial #	A/C Unit #	A/C Registration #	Date	City ID	Total A/C Hours	Total A/C Landings	Total Engine Hrs	Total Engine Cycles	Total Prop Hrs			
208B-5098		RP-C1087	12-Jun-2021	RPLB	3790	6464	3790	6464	1465.2			

Component Changes, Inspections, Service Bulletins, or Airworthiness Directives Accomplished

Item	Transaction No.	Type	Item Name	Position	Part Number / Alternate Part	Mod Level	Part Serial	Removal Reason	Installed Part Status	TSN/TSO/TSR	Material Costs	Man Hours
053401	1	2	UPDATE G1000 NAV DATA									
Comments:												
760000	2	2	NO. 1 ENGINE - DOWNLOAD ECTM									
Comments:												
C122103	3	2	LUBRICATION HARTZELL PROPELLER									
Comments:												

Trans Type: 1 - Component, 2 - Inspection, 3 - SB, 4 - AD, -- Misc.
 Removal Reasons: WO - Worn to Limits, SC - Scheduled, UN - Unscheduled, CO - Convenience, N - Other(note in comments)
 Installed Part Status: N - New, R - Repaired / Rebuilt, S - Serviceable, O - Overhauled, T - Tested, M - Modified, I - Inspected

Repair Facility	SUBIC	Certified Repair Station Number	135-14	Work Order No.	S21-044
Work Performed By	EMERSON PEROCHO	Certificate No.	013397	Date	12-Jun-2021
I certify that the above stated maintenance and/or inspection was performed in accordance with the current regulations of the <input type="checkbox"/> Federal Aviation Administration <input checked="" type="checkbox"/> Other (Specify) CAAP and					
THE AIRCRAFT IDENTIFIED ABOVE IS PRESENTLY AIRWORTHY AND APPROVED FOR RETURN TO SERVICE.					
Work Inspected By	JASON DAYRIT	Certificate No.	102495	Date	12-Jun-2021
Pertinent details of this maintenance are on file at our facility under the above Work/Service Order Number as applicable.					

Maintenance Log	
Book	Page

This Maintenance Report is To Be Used Solely For (Check One)

Airframe Entries
 Eng. Serial No.
 Prop. Serial No.

Aircraft Identification and Status

A/C Serial #	A/C Unit #	A/C Registration #	Date	City ID	Total A/C Hours	Total A/C Landings	Total Engine Hrs	Total Engine Cycles	Total Prop Hrs			
208B-5098		RP-C1087	19-May-2021	RPLB	3790	6464	3790	6464	1465.2			

Component Changes, Inspections, Service Bulletins, or Airworthiness Directives Accomplished

Item	Transaction No.	Type	Item Name	Position	Part Number / Alternate Part	Mod Level	Part Serial	Removal Reason	Installed Part Status	TSN/TSO/TSR	Material Costs	Man Hours
760000	1	2	NO. 1 ENGINE - DOWNLOAD ECTM									
Comments:												
053401	2	2	UPDATE G1000 NAV DATA									
Comments:												

Trans Type: 1 - Component, 2 - Inspection, 3 - SB, 4 - AD, -- Misc.
 Removal Reasons: WO - Worn to Limits, SC - Scheduled, UN - Unscheduled, CO - Convenience, N - Other (note in comments)
 Installed Part Status: N - New, R - Repaired / Rebuilt, S - Serviceable, O - Overhauled, T - Tested, M - Modified, I - Inspected

Repair Facility <u>SUBIC</u>	Certified Repair Station Number <u>135-14</u>	Work Order No. <u>S21-034</u>	
Work Performed By <u>EMERSON PEROCHO</u>	Certificate No. <u>013397</u>	Date <u>19-May-2021</u>	
I certify that the above stated maintenance and/or inspection was performed in accordance with the current regulations of the <input type="checkbox"/> Federal Aviation Administration <input checked="" type="checkbox"/> Other (Specify) <u>CAAP</u> and			
THE AIRCRAFT IDENTIFIED ABOVE IS PRESENTLY AIRWORTHY AND APPROVED FOR RETURN TO SERVICE.			
Work Inspected By <u>JASON DAYRIT</u>	Certificate No. <u>102495-AMS</u>	Date <u>19-May-2021</u>	
Pertinent details of this maintenance are on file at our facility under the above Work/Service Order Number as applicable.			

Maintenance Log	
Book	Page

This Maintenance Report is To Be Used Solely For (Check One)

Airframe Entries
 Eng. Serial No.
 Prop. Serial No.

Aircraft Identification and Status

A/C Serial #	A/C Unit #	A/C Registration #	Date	City ID	Total A/C Hours	Total A/C Landings	Total Engine Hrs	Total Engine Cycles	Total Prop Hrs			
208B-5098		RP-C1087	21-Apr-2021	RPLB	3787.1	6460	3787.1	6460	1462.3			

Component Changes, Inspections, Service Bulletins, or Airworthiness Directives Accomplished

Item	Transaction No.	Type	Item Name	Position	Part Number / Alternate Part	Mod Level	Part Serial	Removal Reason	Installed Part Status	TSN/TSO/TSR	Material Costs	Man Hours
760000	1	2	NO. 1 ENGINE - DOWNLOAD ECTM									
Comments:												
053401	2	2	UPDATE G1000 NAV DATA									
Comments:												

Trans Type: 1 - Component, 2 - Inspection, 3 - SB, 4 - AD, -- Misc.
 Removal Reasons: WO - Worn to Limits, SC - Scheduled, UN - Unscheduled, CO - Convenience, N - Other(note in comments)
 Installed Part Status: N - New, R - Repaired / Rebuilt, S - Serviceable, O - Overhauled, T - Tested, M - Modified, I - Inspected

Repair Facility	SUBIC	Certified Repair Station Number	135-14	Work Order No.	S21-031
Work Performed By	EMERSON PEROCHO	Certificate No.	013397	Date	21-Apr-2021
I certify that the above stated maintenance and/or inspection was performed in accordance with the current regulations of the <input type="checkbox"/> Federal Aviation Administration <input checked="" type="checkbox"/> Other (Specify) _____ CAAP _____ and _____					
THE AIRCRAFT IDENTIFIED ABOVE IS PRESENTLY AIRWORTHY AND APPROVED FOR RETURN TO SERVICE.					
Work Inspected By	JASON DAYRIT	Certificate No.	102495	Date	21-Apr-2021
Pertinent details of this maintenance are on file at our facility under the above Work/Service Order Number as applicable.					

Maintenance Log	
Book	Page

This Maintenance Report is To Be Used Solely For (Check One)

Airframe Entries
 Eng. Serial No.
 Prop. Serial No.

Aircraft Identification and Status

A/C Serial #	A/C Unit #	A/C Registration #	Date	City ID	Total A/C Hours	Total A/C Landings	Total Engine Hrs	Total Engine Cycles	Total Prop Hrs			
208B-5098		RP-C1087	10-Apr-2021	RPLB	3781.6	6454	3781.6	6454	1456.8			

Component Changes, Inspections, Service Bulletins, or Airworthiness Directives Accomplished

Item	Transaction No.	Type	Item Name	Position	Part Number / Alternate Part	Mod Level	Part Serial	Removal Reason	Installed Part Status	TSN/TSO/TSR	Material Costs	Man Hours
051001	1	2	RENEWAL AIRWORTHINESS									
Comments: Date of Issue: 4-Dec-20 Date of Expiry: 4-Dec-21												

Trans Type: 1 - Component, 2 - Inspection, 3 - SB, 4 - AD, -- Misc.
 Removal Reasons: WO - Worn to Limits, SC - Scheduled, UN - Unscheduled, CO - Convenience, N - Other(note in comments)
 Installed Part Status: N - New, R - Repaired / Rebuilt, S - Serviceable, O - Overhauled, T - Tested, M - Modified, I - Inspected

Repair Facility _____	Certified Repair Station Number _____	Work Order No. _____	
_____ SUBIC	_____ 135-14	_____ S21-030	
Work Performed By _____	Certificate No. _____	Date _____	
_____ VINCENT TERO	_____ 012697-AMT	_____ 10-Apr-2021	
I certify that the above stated maintenance and/or inspection was performed in accordance with the current regulations of the			
<input type="checkbox"/> Federal Aviation Administration <input checked="" type="checkbox"/> Other (Specify) _____ CAAP _____ and _____			
THE AIRCRAFT IDENTIFIED ABOVE IS PRESENTLY AIRWORTHY AND APPROVED FOR RETURN TO SERVICE.			
Work Inspected By _____	Certificate No. _____	Date _____	
_____ JASON DAYRIT	_____ 102495	_____ 10-Apr-2021	
Pertinent details of this maintenance are on file at our facility under the above Work/Service Order Number as applicable.			

Maintenance Log	
Book	Page



Maintenance Transaction Record

CAMP MTR ID # 3234515



This Maintenance Report is To Be Used Solely For (Check One)

Airframe Entries

Eng. Serial No.

Prop. Serial No.

Aircraft Identification and Status

A/C Serial #	A/C Unit #	A/C Registration #	Date	City ID	Total A/C Hours	Total A/C Landings	Total Engine Hrs	Total Engine Cycles	Total Prop Hrs			
208B-5098		RP-C1087	10-Apr-2021	RPLB	3781.6	6454	3781.6	6454	1456.8			

Component Changes, Inspections, Service Bulletins, or Airworthiness Directives Accomplished

Item	Transaction No.	Type	Item Name	Position	Part Number / Alternate Part	Mod Level	Part Serial	Removal Reason	Installed Part Status	TSN/TSO/TSR	Material Costs	Man Hours
FAA 2021-07-13 PARA (E)(1)	1	4	INSPECT THE BUCKLE HANDLE FOR A CRACK AND IF CRACKED, BEFORE FURTHER FLIGHT, REPLACE IT WITH AN AIRWORTHY BUCKLE									
MOC: NOT APPLICABLE Comments: Due to Different Part No. and No Crack Found												
FAA 2021-07-13 PARA (E)(2)	2	4	MEASURE THE THICKNESS OF THE BUCKLE HANDLE VANE; IF THICKNESS IS 0.125 INCH OR GREATER, BEFORE FURTHER FLIGHT, REMOVE THE BUCKLE FROM SERVICE AND REPLACE IT WITH AN AIRWORTHY BUCKLE									
MOC: NOT APPLICABLE Comments: Due to Different Part No. and Vane Less than .125 Inch												

Trans Type: 1 - Component, 2 - Inspection, 3 - SB, 4 - AD, -- Misc.

Removal Reasons: WO - Worn to Limits, SC - Scheduled, UN - Unscheduled, CO - Convenience, N - Other(note in comments)

Installed Part Status: N - New, R - Repaired / Rebuilt, S - Serviceable, O - Overhauled, T - Tested, M - Modified, I - Inspected

Repair Facility	SUBIC	Certified Repair Station Number	135-14	Work Order No.	S21-030
Work Performed By	VINCENT TERO	Certificate No.	012697-AMT	Date	10-Apr-2021
I certify that the above stated maintenance and/or inspection was performed in accordance with the current regulations of the					
<input type="checkbox"/> Federal Aviation Administration					
<input checked="" type="checkbox"/> Other (Specify) CAAP and					
THE AIRCRAFT IDENTIFIED ABOVE IS PRESENTLY AIRWORTHY AND APPROVED FOR RETURN TO SERVICE.					
Work Inspected By	JASON DAYRIT	Certificate No.	102495	Date	10-Apr-2021
Pertinent details of this maintenance are on file at our facility under the above Work/Service Order Number as applicable.					

Maintenance Log	
Book	Page



Maintenance Transaction Record

CAMP MTR ID # 3229891



This Maintenance Report is To Be Used Solely For (Check One)

Airframe Entries
 Eng. Serial No.
 Prop. Serial No.

Aircraft Identification and Status

A/C Serial #	A/C Unit #	A/C Registration #	Date	City ID	Total A/C Hours	Total A/C Landings	Total Engine Hrs	Total Engine Cycles	Total Prop Hrs			
208B-5098		RP-C1087	24-Mar-2021	CYZ	3758.9	6392	3758.9	6392	1434.1			

Component Changes, Inspections, Service Bulletins, or Airworthiness Directives Accomplished

Item	Transaction No.	Type	Item Name	Position	Part Number / Alternate Part	Mod Level	Part Serial	Removal Reason	Installed Part Status	TSN/TSO/TSR	Material Costs	Man Hours
053401	1	2	UPDATE G1000 NAV DATA									
Comments:												

Trans Type: 1 - Component, 2 - Inspection, 3 - SB, 4 - AD, -- Misc.
 Removal Reasons: WO - Worn to Limits, SC - Scheduled, UN - Unscheduled, CO - Convenience, N - Other(note in comments)
 Installed Part Status: N - New, R - Repaired / Rebuilt, S - Serviceable, O - Overhauled, T - Tested, M - Modified, I - Inspected

Repair Facility	SUBIC	Certified Repair Station Number	135-14	Work Order No.	C210009
Work Performed By	JASON DAYRIT	Certificate No.	102495	Date	24-Mar-2021
I certify that the above stated maintenance and/or inspection was performed in accordance with the current regulations of the <input type="checkbox"/> Federal Aviation Administration <input checked="" type="checkbox"/> Other (Specify) CAAP _____ and THE AIRCRAFT IDENTIFIED ABOVE IS PRESENTLY AIRWORTHY AND APPROVED FOR RETURN TO SERVICE.					
Work Inspected By	JASON DAYRIT	Certificate No.	102495	Date	24-Mar-2021
Pertinent details of this maintenance are on file at our facility under the above Work/Service Order Number as applicable.					

Maintenance Log	
Book	Page

Maintenance Transaction Record

CAMP MTR ID # 3224704

This Maintenance Report is To Be Used Solely For (Check One)

Airframe Entries
 Eng. Serial No.
 Prop. Serial No.

Aircraft Identification and Status

A/C Serial #	A/C Unit #	A/C Registration #	Date	City ID	Total A/C Hours	Total A/C Landings	Total Engine Hrs	Total Engine Cycles	Total Prop Hrs			
208B-5098		RP-C1087	23-Mar-2021	RPLB	3753.6	6381	3753.6	6381	3753.6			

Component Changes, Inspections, Service Bulletins, or Airworthiness Directives Accomplished

Item	Transaction No.	Type	Item Name	Position	Part Number / Alternate Part	Mod Level	Part Serial	Removal Reason	Status	Installed Part TSN/TSO/TSR	Material Costs	Man Hours
350302	1	1	LEFT OXYGEN MASK	LEFT	NPN		NSN	N	N	0 MTH		
Comments: NA due to No oxygen mask Installed												
350302	2	1	RIGHT OXYGEN MASK	RIGHT	NPN		NSN	N	N	0 MTH		
Comments: NA due to No Oxygen Mask Installed												

Trans Type: 1 - Component, 2 - Inspection, 3 - SB, 4 - AD, -- Misc.
 Removal Reasons: WO - Worn to Limits, SC - Scheduled, UN - Unscheduled, CO - Convenience, N - Other(note in comments)
 Installed Part Status: N - New, R - Repaired / Rebuilt, S - Serviceable, O - Overhauled, T - Tested, M - Modified, I - Inspected

Repair Facility	SUBIC	Certified Repair Station Number	135-14	Work Order No.	S21-024
Work Performed By	VINCENT TERO	Certificate No.	012697-AMT	Date	23-Mar-2021
I certify that the above stated maintenance and/or inspection was performed in accordance with the current regulations of the <input type="checkbox"/> Federal Aviation Administration <input checked="" type="checkbox"/> Other (Specify) CAAP and					
THE AIRCRAFT IDENTIFIED ABOVE IS PRESENTLY AIRWORTHY AND APPROVED FOR RETURN TO SERVICE.					
Work Inspected By	JASON DAYRIT	Certificate No.	102495	Date	23-Mar-2021
Pertinent details of this maintenance are on file at our facility under the above Work/Service Order Number as applicable.					

Maintenance Log	
Book	Page



Maintenance Transaction Record

CAMP MTR ID # 3223639



This Maintenance Report is To Be Used Solely For (Check One)

Airframe Entries

Eng. Serial No.

Prop. Serial No.

Aircraft Identification and Status

A/C Serial #	A/C Unit #	A/C Registration #	Date	City ID	Total A/C Hours	Total A/C Landings	Total Engine Hrs	Total Engine Cycles	Total Prop Hrs			
208B-5098		RP-C1087	22-Mar-2021	RPLB	3753.6	6381	3753.6	6381	3753.6			

Component Changes, Inspections, Service Bulletins, or Airworthiness Directives Accomplished

Item	Transaction No.	Type	Item Name	Position	Part Number / Alternate Part	Mod Level	Part Serial	Removal Reason	Status	Installed Part TSN/TSO/TSR	Material Costs	Man Hours
3223639	1	1	LIFE VEST NO.1	PILOT DOOR	P01202-101		20121220002	WO	N	0 MTH 0 HRS		
Comments: Reinspect By: 2025-12-23												
3223639	2	-	LIFE VEST NO. 2	CO-PILOT DOOR	P01202-101		201212200019	WO	N	0 MTH 0 HRS		
Comments: Reinspect By: 2025-12-23												
3223639003	3	-	LIFE VEST NO. 3		P01202-101		20121220004	WO	N	0 MTH 0 HRS		
Comments: Reinspect By: 2025-12-23												
3223639004	4	-	LIFE VEST NO. 4		P01202-101		20121220014	WO	N	0 MTH 0 HRS		
Comments: Reinspect By: 2025-12-23												
3223639	5	-	LIFE VEST NO. 5		P01202-101		20121220009	WO	N	0 MTH 0 HRS		
Comments: Reinspect By: 2025-12-23												
3223639006	6	-	LIFE VEST NO. 6		P01202-101		20121220003	WO	N	0 MTH 0 HRS		
Comments: Reinspect By: 2025-12-23												
3223639007	7	-	LIFE VEST NO. 7		P01202-101		20121220011	WO	N	0 MTH 0 HRS		
Comments: Reinspect By: 2025-12-23												

Trans Type: 1 - Component, 2 - Inspection, 3 - SB, 4 - AD, -- Misc.

Removal Reasons: WO - Worn to Limits, SC - Scheduled, UN - Unscheduled, CO - Convenience, N - Other(note in comments)

Installed Part Status: N - New, R - Repaired / Rebuilt, S - Serviceable, O - Overhauled, T - Tested, M - Modified, I - Inspected

Repair Facility	SUBIC	Certified Repair Station Number	135-14	Work Order No.	S21-022
Work Performed By	EMERSON PEROCHO	Certificate No.	013397	Date	22-Mar-2021
I certify that the above stated maintenance and/or inspection was performed in accordance with the current regulations of the					
<input type="checkbox"/> Federal Aviation Administration					
<input checked="" type="checkbox"/> Other (Specify) CAAP and					
THE AIRCRAFT IDENTIFIED ABOVE IS PRESENTLY AIRWORTHY AND APPROVED FOR RETURN TO SERVICE.					
Work Inspected By	JASON DAYRIT	Certificate No.	102495	Date	22-Mar-2021
Pertinent details of this maintenance are on file at our facility under the above Work/Service Order Number as applicable.					

Maintenance Log	
Book	Page



Maintenance Transaction Record

CAMP MTR ID # 3223639



This Maintenance Report is To Be Used Solely For (Check One)

Airframe Entries

Eng. Serial No.

Prop. Serial No.

Aircraft Identification and Status

A/C Serial #	A/C Unit #	A/C Registration #	Date	City ID	Total A/C Hours	Total A/C Landings	Total Engine Hrs	Total Engine Cycles	Total Prop Hrs			
208B-5098		RP-C1087	22-Mar-2021	RPLB	3753.6	6381	3753.6	6381	3753.6			

Component Changes, Inspections, Service Bulletins, or Airworthiness Directives Accomplished

Item	Transaction No.	Type	Item Name	Position	Part Number / Alternate Part	Mod Level	Part Serial	Removal Reason	Status	Installed Part TSN/TSO/TSR	Material Costs	Man Hours
3223639008	8	-	LIFE VEST NO. 8		P01202-101		20121220018	WO	N	0 MTH 0 HRS		
Comments: Reinspect By: 2025-12-23												
3223639009	9	-	LIFE VEST NO. 9		P01202-101		20121220010	WO	N	0 MTH 0 HRS		
Comments: Reinspect By: 2025-12-23												
3223639010	10	-	LIFE VEST NO. 10		P01202-101		20121220015	WO	N	0 MTH 0 HRS		
Comments: Reinspect By: 2025-12-23												
3223639011	11	-	LIFE VEST NO. 11		P01202-101		20121220005	WO	N	0 MTH 0 HRS		
Comments: Reinspect By: 2025-12-23												

Trans Type: 1 - Component, 2 - Inspection, 3 - SB, 4 - AD, -- Misc.

Removal Reasons: WO - Worn to Limits, SC - Scheduled, UN - Unscheduled, CO - Convenience, N - Other(note in comments)

Installed Part Status: N - New, R - Repaired / Rebuilt, S - Serviceable, O - Overhauled, T - Tested, M - Modified, I - Inspected

Repair Facility	SUBIC	Certified Repair Station Number	135-14	Work Order No.	S21-022
Work Performed By	EMERSON PEROCHO	Certificate No.	013397	Date	22-Mar-2021
I certify that the above stated maintenance and/or inspection was performed in accordance with the current regulations of the					
<input type="checkbox"/> Federal Aviation Administration					
<input checked="" type="checkbox"/> Other (Specify) CAAP and					
THE AIRCRAFT IDENTIFIED ABOVE IS PRESENTLY AIRWORTHY AND APPROVED FOR RETURN TO SERVICE.					
Work Inspected By	JASON DAYRIT	Certificate No.	102495	Date	22-Mar-2021
Pertinent details of this maintenance are on file at our facility under the above Work/Service Order Number as applicable.					

Maintenance Log	
Book	Page

Maintenance Transaction Record

CAMP MTR ID # 3229899

This Maintenance Report is To Be Used Solely For (Check One)

Airframe Entries
 Eng. Serial No.
 Prop. Serial No.

Aircraft Identification and Status

A/C Serial #	A/C Unit #	A/C Registration #	Date	City ID	Total A/C Hours	Total A/C Landings	Total Engine Hrs	Total Engine Cycles	Total Prop Hrs			
208B-5098		RP-C1087	21-Mar-2021	RPLB	3753.6	6381	3753.6	6381	1428.8			

Component Changes, Inspections, Service Bulletins, or Airworthiness Directives Accomplished

Item	Transaction No.	Type	Item Name	Position	Part Number / Alternate Part	Mod Level	Part Serial	Removal Reason	Installed Part Status	TSN/TSO/TSR	Material Costs	Man Hours
B262001	1	2	WEIGHT CHECK FORWARD FIRE EXTINGUISHER PORTABLE	FORWARD	C352TS		Y-649628					
			WEIGHT CHECK Date: 21-Mar-2021									
			Comments:									

Trans Type: 1 - Component, 2 - Inspection, 3 - SB, 4 - AD, -- Misc.
 Removal Reasons: WO - Worn to Limits, SC - Scheduled, UN - Unscheduled, CO - Convenience, N - Other(note in comments)
 Installed Part Status: N - New, R - Repaired / Rebuilt, S - Serviceable, O - Overhauled, T - Tested, M - Modified, I - Inspected

Repair Facility _____	Certified Repair Station Number _____	Work Order No. _____
SUBIC	135-14	S21-009
Work Performed By _____	Certificate No. _____	Date _____
VINCENT TERO	012697-AMT	21-Mar-2021
I certify that the above stated maintenance and/or inspection was performed in accordance with the current regulations of the <input type="checkbox"/> Federal Aviation Administration <input checked="" type="checkbox"/> Other (Specify) _____ CAAP _____ and _____		
THE AIRCRAFT IDENTIFIED ABOVE IS PRESENTLY AIRWORTHY AND APPROVED FOR RETURN TO SERVICE.		
Work Inspected By _____	Certificate No. _____	Date _____
JASON DAYRIT	102495	21-Mar-2021
Pertinent details of this maintenance are on file at our facility under the above Work/Service Order Number as applicable.		

Maintenance Log	
Book	Page



Maintenance Transaction Record

CAMP MTR ID # 3229896



This Maintenance Report is To Be Used Solely For (Check One)

Airframe Entries
 Eng. Serial No.
 Prop. Serial No.

Aircraft Identification and Status

A/C Serial #	A/C Unit #	A/C Registration #	Date	City ID	Total A/C Hours	Total A/C Landings	Total Engine Hrs	Total Engine Cycles	Total Prop Hrs			
208B-5098		RP-C1087	21-Mar-2021	RPLB	3753.6	6381	3753.6	6381	1428.8			

Component Changes, Inspections, Service Bulletins, or Airworthiness Directives Accomplished

Item	Transaction No.	Type	Item Name	Position	Part Number / Alternate Part	Mod Level	Part Serial	Removal Reason	Installed Part Status	TSN/TSO/TSR	Material Costs	Man Hours
5-15-01	1	2	INSPECTION DOCUMENT 01									
Comments:												

Trans Type: 1 - Component, 2 - Inspection, 3 - SB, 4 - AD, -- Misc.
 Removal Reasons: WO - Worn to Limits, SC - Scheduled, UN - Unscheduled, CO - Convenience, N - Other(note in comments)
 Installed Part Status: N - New, R - Repaired / Rebuilt, S - Serviceable, O - Overhauled, T - Tested, M - Modified, I - Inspected

Repair Facility	SUBIC	Certified Repair Station Number	135-14	Work Order No.	S21-019
Work Performed By	VINCENT TERO	Certificate No.	012697-AMT	Date	21-Mar-2021
I certify that the above stated maintenance and/or inspection was performed in accordance with the current regulations of the <input type="checkbox"/> Federal Aviation Administration <input checked="" type="checkbox"/> Other (Specify) CAAP and					
THE AIRCRAFT IDENTIFIED ABOVE IS PRESENTLY AIRWORTHY AND APPROVED FOR RETURN TO SERVICE.					
Work Inspected By	JASON DAYRIT	Certificate No.	102495	Date	21-Mar-2021
Pertinent details of this maintenance are on file at our facility under the above Work/Service Order Number as applicable.					

Maintenance Log	
Book	Page

Maintenance Transaction Record

CAMP MTR ID # 3229887

This Maintenance Report is To Be Used Solely For (Check One)

Airframe Entries

Eng. Serial No.

Prop. Serial No.

Aircraft Identification and Status

A/C Serial #	A/C Unit #	A/C Registration #	Date	City ID	Total A/C Hours	Total A/C Landings	Total Engine Hrs	Total Engine Cycles	Total Prop Hrs			
208B-5098		RP-C1087	21-Mar-2021	RPLB	3753.6	6381	3753.6	6381	1428.8			

Component Changes, Inspections, Service Bulletins, or Airworthiness Directives Accomplished

Item	Transaction No.	Type	Item Name	Position	Part Number / Alternate Part	Mod Level	Part Serial	Removal Reason	Installed Part Status	TSN/TSO/TSR	Material Costs	Man Hours
057010	1	2	NO. 1 ENGINE - MINOR INSPECTION									
Comments:												
5-15-06	2	2	INSPECTION DOCUMENT 06									
Comments:												

Trans Type: 1 - Component, 2 - Inspection, 3 - SB, 4 - AD, -- Misc.

Removal Reasons: WO - Worn to Limits, SC - Scheduled, UN - Unscheduled, CO - Convenience, N - Other (note in comments)

Installed Part Status: N - New, R - Repaired / Rebuilt, S - Serviceable, O - Overhauled, T - Tested, M - Modified, I - Inspected

Repair Facility	SUBIC	Certified Repair Station Number	135-14	Work Order No.	S21-019
Work Performed By	VINCENT TERO	Certificate No.	012697-AMT	Date	21-Mar-2021
<p>I certify that the above stated maintenance and/or inspection was performed in accordance with the current regulations of the</p> <p><input type="checkbox"/> Federal Aviation Administration <input checked="" type="checkbox"/> Other (Specify) CAAP and</p> <p>THE AIRCRAFT IDENTIFIED ABOVE IS PRESENTLY AIRWORTHY AND APPROVED FOR RETURN TO SERVICE.</p>					
Work Inspected By	JASON DAYRIT	Certificate No.	102495	Date	21-Mar-2021
<p>Pertinent details of this maintenance are on file at our facility under the above Work/Service Order Number as applicable.</p>					

Maintenance Log	
Book	Page

This Maintenance Report is To Be Used Solely For (Check One)

Airframe Entries
 Eng. Serial No.
 Prop. Serial No.

Aircraft Identification and Status

A/C Serial #	A/C Unit #	A/C Registration #	Date	City ID	Total A/C Hours	Total A/C Landings	Total Engine Hrs	Total Engine Cycles	Total Prop Hrs		
208B-5098		RP-C1087	24-Feb-2021	RPLB	3702.4	6245	3702.4	6245	3702.4		

Component Changes, Inspections, Service Bulletins, or Airworthiness Directives Accomplished

Item	Transaction No.	Type	Item Name	Position	Part Number / Alternate Part	Mod Level	Part Serial	Removal Reason	Installed Part Status	TSN/TSO/TSR	Material Costs	Man Hours
053401	1	2	UPDATE G1000 NAV DATA									

Comments:

Trans Type: 1 - Component, 2 - Inspection, 3 - SB, 4 - AD, -- Misc.
 Removal Reasons: WO - Worn to Limits, SC - Scheduled, UN - Unscheduled, CO - Convenience, N - Other(note in comments)
 Installed Part Status: N - New, R - Repaired / Rebuilt, S - Serviceable, O - Overhauled, T - Tested, M - Modified, I - Inspected

Repair
 Certified Repair
 Work
 Maintenance Log



JOB NO	AHAI20-OTHR-00
A/C REG	RP-C 1087
OWNER	AIRJUAN AVIATION INC.
DATE	NOV. 16, 2020

MAKE	TEXTRON AVIATION INC.	MAKE/DEL	N/A		MAKE	N/A
MODEL	C208B EX	SN	N/A	SN	MODEL	N/A
SN	5098	TSN	N/A	TSN	SN	N/A
ENGINES		TSD	N/A	TSD	TSN	N/A
TACH	N/A	CSN	N/A	CSN	TSO	N/A
AFIT	3089	CSD	N/A	CSD	SN	N/A
CYC	N/A	TSD	N/A	TSD	TSN	N/A
		CSN	N/A	CSN	TSO	N/A

(THE WORK DETAILED BELOW HAS BEEN CARRIED-OUT ON THE ABOVE)

PERFORMED ALTIMETER PITOT-STATIC SYSTEM TEST USING BARFIELD PITOT-STATIC TEST EQUIPMENT TO VERIFY PROPER OPERATION AND IN COMPLIANCE WITH CAAP CAR PART 8.2.1.7 (a)(3). SYSTEM WAS TESTED UP TO 25,000 FT ALTITUDE AND BEEN FOUND SATISFACTORY.

PERFORMED TRANSPONDER MODE AIRCRAFT TEST USING BARFIELD AND ATC600A TEST EQUIPMENT TO VERIFY PROPER OPERATION AND IN COMPLIANCE WITH CAAP CAR PART 8.2.1.7 (a)(4). TRANSPONDER WAS TESTED UP TO 25,000 FT ALTITUDE AND SYSTEM BEEN FOUND SATISFACTORY.

PERFORMED ELT INSPECTION AND FUNCTIONAL TEST USING ELT TESTER EQUIPMENT TO VERIFY PROPER OPERATION AND IN COMPLIANCE WITH CAAP CAR PART 8.2.1.7 (a)(5). SYSTEM BEEN FOUND SATISFACTORY.

***** UNIT DETAILS *****

UNIT	PART NUMBER	SERIAL NUMBER
TRANSPONDER	011-00779-10	89128030
TRANSPONDER	011-00779-10	89127200
AIR DATA COMPUTER	GDC 74	20616512
AIR DATA COMPUTER	GDC 74	20623184
ELT	C406N	14616

***** EQUIPMENT USED AND ITS CALIBRATION EXPIRATION *****

EQUIPMENT	MODEL	SERIAL NUMBER	RECALIBRATION DUE DATE
BARFIELD PITOT-STATIC TEST SET	1811G845	657	March 11, 2021
TRANSPONDER RAMP TEST SET	ATC600A	1392	March 11, 2021
ICARUS ELT TESTER	ELTT-124	14259	April 2022

***** NOTHING FOLLOWS *****

Test Performed By [Signature]
 Name / License Number CEA/B. SICAT MYG.50-AHS
 Avionics Technician

I hereby certify that the Inspection/Overhaul/Repair/Replacement/Modification specified above has been carried-out in accordance with current Civil Air Regulations and was found airworthy for return to service.

Signed [Signature] 11302 ATTS (for Aviation) Hub Asia, Inc. AMO No 181-18 Dated NOV. 16, 2020

NOTE: This Certificate constitutes a logbook entry and must be affixed in appropriate logbook.

This Maintenance Report is To Be Used Solely For (Check One)

Airframe Entries
 Eng. Serial No.
 Prop. Serial No.

Aircraft Identification and Status

A/C Serial #	A/C Registration #	Date	City ID	Total A/C Hours	Total A/C Landings	Total Engine Hrs	Total Engine Cycles	Total Prop Hrs			
208B-5098	RP-C1087	17-Nov-2020	RPLB	3669	6205	3669	6205	1344.2			

Component Changes, Inspections, Service Bulletins, or Airworthiness Directives Accomplished

Item	Transaction No.	Type	Item Name	Position	Part Number / Alternate Part	Mod Level	Part Serial	Removal Reason	Status	Installed Part TSN/TSO/TSR	Material Costs	Man Hours
240301	1	1	STARTER GENERATOR		200SGL153Q		3798XL	WO	N	0 HRS		
Comments: Removed part no: 200SGL153Q-1 Removed serial no: 2078XL. Installed part no.: 200SGL153Q Installed serial no.: 3798XL.												

Trans Type: 1 - Component, 2 - Inspection, 3 - SB, 4 - AD, -- Misc.
 Removal Reasons: WO - Worn to Limits, SC - Scheduled, UN - Unscheduled, CO - Convenience, N - Other(note in comments)
 Installed Part Status: N - New, R - Repaired / Rebuilt, S - Serviceable, O - Overhauled, T - Tested, M - Modified, I - Inspected

Repair Facility	AIR JUAN AVIATION INC.	Certified Repair Station Number	135-14
Work Performed By	JASON DAYRIT	Certificate No.	102495
		Date	17-Nov-2020
		Work Order No.	S20-015

I certify that the above stated maintenance and/or inspection was performed in accordance with the current regulations of the

Federal Aviation Administration
 Other (Specify) CAAP _____ and

THE AIRCRAFT IDENTIFIED ABOVE IS PRESENTLY AIRWORTHY AND APPROVED FOR RETURN TO SERVICE.

Work Inspected By	M. MARTINEZ	Certificate No.	112468
		Date	17-Nov-2020

Pertinent details of this maintenance are on file at our facility under the above Work/Service Order Number as applicable.

Maintenance Log	
Book	Page

This Maintenance Report is To Be Used Solely For (Check One)

Airframe Entries
 Eng. Serial No.
 Prop. Serial No.

Aircraft Identification and Status

A/C Serial #	A/C Unit #	A/C Registration #	Date	City ID	Total A/C Hours	Total A/C Landings	Total Engine Hrs	Total Engine Cycles	Total Prop Hrs			
208B-5098		RP-C1087	16-Nov-2020	RPLB	3673.1	6209	3673.1	6209	239.5			

Component Changes, Inspections, Service Bulletins, or Airworthiness Directives Accomplished

Item	Transaction No.	Type	Item Name	Position	Part Number / Alternate Part	Mod Level	Part Serial	Removal Reason	Installed Part Status	TSN/TSO/TSR	Material Costs	Man Hours
5-15-20	1	2	INSPECTION DOCUMENT 20									
Comments:												
5-15-22	2	2	INSPECTION DOCUMENT 22 (PLEASE REFER TO INDIVIDUAL SUBTASKS FOR DUE TIMES)									
Comments:												
B341103	3	2	CALIBRATION TEST STANDBY ALTIMETER STANDBY (FAR 91.411)		5934PAD-3DA.657		502525					
Comments:												
B341103	4	2	FUNCTION CHECK LEFT HAND PITOT/STATIC SYSTEM (91.411)	LEFT HAND								
Comments:												
B341103	5	2	FUNCTION CHECK RIGHT HAND PITOT/STATIC SYSTEM (91.411)	RIGHT HAND								
Comments:												

Trans Type: 1 - Component, 2 - Inspection, 3 - SB, 4 - AD, -- Misc.
 Removal Reasons: WO - Worn to Limits, SC - Scheduled, UN - Unscheduled, CO - Convenience, N - Other(note in comments)
 Installed Part Status: N - New, R - Repaired / Rebuilt, S - Serviceable, O - Overhauled, T - Tested, M - Modified, I - Inspected

Repair Facility	SUBIC	Certified Repair Station Number	135-14	Work Order No.	S20-015A
Work Performed By	AVIATION HUB	Certificate No.	151-16	Date	16-Nov-2020
I certify that the above stated maintenance and/or inspection was performed in accordance with the current regulations of the <input type="checkbox"/> Federal Aviation Administration <input checked="" type="checkbox"/> Other (Specify) CAAP and					
THE AIRCRAFT IDENTIFIED ABOVE IS PRESENTLY AIRWORTHY AND APPROVED FOR RETURN TO SERVICE.					
Work Inspected By	MIKE MARTINEZ	Certificate No.	112468	Date	16-Nov-2020
Pertinent details of this maintenance are on file at our facility under the above Work/Service Order Number as applicable.					

Maintenance Log	
Book	Page

This Maintenance Report is To Be Used Solely For (Check One)

Airframe Entries
 Eng. Serial No.
 Prop. Serial No.

Aircraft Identification and Status

A/C Serial #	A/C Unit #	A/C Registration #	Date	City ID	Total A/C Hours	Total A/C Landings	Total Engine Hrs	Total Engine Cycles	Total Prop Hrs			
208B-5098		RP-C1087	31-Mar-2020	RPVM	3628.8	6166	3628.8	6166	3628.8			

Component Changes, Inspections, Service Bulletins, or Airworthiness Directives Accomplished

Item	Transaction No.	Type	Item Name	Position	Part Number / Alternate Part	Mod Level	Part Serial	Removal Reason	Installed Part Status	TSN/TSO/TSR	Material Costs	Man Hours
B262001	1	2	WEIGHT CHECK FORWARD FIRE EXTINGUISHER PORTABLE WEIGHT CHECK Date: 31-Mar-2020 Comments:	FORWARD	C352TS		Y-649628					
370103	2	1	VACUUM RELIEF VALVE FILTER DISCARD Comments:		C482001-0202		NSN	SC	N	0 MTH 0 HRS		
5-15-01	3	2	INSPECTION DOCUMENT 01 Comments:									

Trans Type: 1 - Component, 2 - Inspection, 3 - SB, 4 - AD, -- Misc.
 Removal Reasons: WO - Worn to Limits, SC - Scheduled, UN - Unscheduled, CO - Convenience, N - Other(note in comments)
 Installed Part Status: N - New, R - Repaired / Rebuilt, S - Serviceable, O - Overhauled, T - Tested, M - Modified, I - Inspected

Repair Facility	SUBIC	Certified Repair Station Number	135-14	Work Order No.	C200012
Work Performed By	FREDERICK MALON	Certificate No.	110092	Date	31-Mar-2020
I certify that the above stated maintenance and/or inspection was performed in accordance with the current regulations of the <input type="checkbox"/> Federal Aviation Administration <input checked="" type="checkbox"/> Other (Specify) CAAP and					
THE AIRCRAFT IDENTIFIED ABOVE IS PRESENTLY AIRWORTHY AND APPROVED FOR RETURN TO SERVICE.					
Work Inspected By	FERNANDO PANGAN	Certificate No.	AJAI002	Date	31-Mar-2020
Pertinent details of this maintenance are on file at our facility under the above Work/Service Order Number as applicable.					

Maintenance Log	
Book	Page



Maintenance Transaction Record

CAMP MTR ID # 3225965



This Maintenance Report is To Be Used Solely For (Check One)

Airframe Entries
 Eng. Serial No.
 Prop. Serial No.

Aircraft Identification and Status

A/C Serial #	A/C Unit #	A/C Registration #	Date	City ID	Total A/C Hours	Total A/C Landings	Total Engine Hrs	Total Engine Cycles	Total Prop Hrs			
208B-5098		RP-C1087	31-Mar-2020	RPVM	3628.8	6166	3628.8	6166	195.2			

Component Changes, Inspections, Service Bulletins, or Airworthiness Directives Accomplished

Item	Transaction No.	Type	Item Name	Position	Part Number / Alternate Part	Mod Level	Part Serial	Removal Reason	Installed Part Status	TSN/TSO/TSR	Material Costs	Man Hours
5-15-02	1	2	INSPECTION DOCUMENT 02									
Comments:												
5-15-04	2	2	INSPECTION DOCUMENT 04									
Comments:												
5-15-11	3	2	INSPECTION DOCUMENT 11									
Comments:												

Trans Type: 1 - Component, 2 - Inspection, 3 - SB, 4 - AD, -- Misc.
 Removal Reasons: WO - Worn to Limits, SC - Scheduled, UN - Unscheduled, CO - Convenience, N - Other(note in comments)
 Installed Part Status: N - New, R - Repaired / Rebuilt, S - Serviceable, O - Overhauled, T - Tested, M - Modified, I - Inspected

Repair Facility	SUBIC	Certified Repair Station Number	135-14	Work Order No.	C200012A
Work Performed By	VINCENT TERO	Certificate No.	012697-AMT	Date	31-Mar-2020
I certify that the above stated maintenance and/or inspection was performed in accordance with the current regulations of the <input type="checkbox"/> Federal Aviation Administration <input checked="" type="checkbox"/> Other (Specify) CAAP and					
THE AIRCRAFT IDENTIFIED ABOVE IS PRESENTLY AIRWORTHY AND APPROVED FOR RETURN TO SERVICE.					
Work Inspected By	MIKE MARTINEZ	Certificate No.	112468	Date	31-Mar-2020
Pertinent details of this maintenance are on file at our facility under the above Work/Service Order Number as applicable.					

Maintenance Log	
Book	Page



Maintenance Transaction Record

CAMP MTR ID # 3226256



This Maintenance Report is To Be Used Solely For (Check One)

Airframe Entries
 Eng. Serial No.
 Prop. Serial No.

Aircraft Identification and Status

A/C Serial #	A/C Unit #	A/C Registration #	Date	City ID	Total A/C Hours	Total A/C Landings	Total Engine Hrs	Total Engine Cycles	Total Prop Hrs			
208B-5098		RP-C1087	31-Mar-2020	RPVM	3628.8	6166	3628.8	6166	195.2			

Component Changes, Inspections, Service Bulletins, or Airworthiness Directives Accomplished

Item	Transaction No.	Type	Item Name	Position	Part Number / Alternate Part	Mod Level	Part Serial	Removal Reason	Status	Installed Part TSN/TSO/TSR	Material Costs	Man Hours
370102	1	1	VACUUM SYSTEM CENTRAL AIR FILTER DISCARD		AAD-9-18-1		NSN	SC	N	0 MTH 0 HRS		
Comments: Removed part no: AAD-9-18-1 Removed serial no: NSN.												

Trans Type: 1 - Component, 2 - Inspection, 3 - SB, 4 - AD, -- Misc.
 Removal Reasons: WO - Worn to Limits, SC - Scheduled, UN - Unscheduled, CO - Convenience, N - Other(note in comments)
 Installed Part Status: N - New, R - Repaired / Rebuilt, S - Serviceable, O - Overhauled, T - Tested, M - Modified, I - Inspected

Repair Facility	SUBIC	Certified Repair Station Number	135-14	Work Order No.	C2000012
Work Performed By	FREDERICK MALON	Certificate No.	110092	Date	31-Mar-2020
I certify that the above stated maintenance and/or inspection was performed in accordance with the current regulations of the <input type="checkbox"/> Federal Aviation Administration <input checked="" type="checkbox"/> Other (Specify) CAAP and					
THE AIRCRAFT IDENTIFIED ABOVE IS PRESENTLY AIRWORTHY AND APPROVED FOR RETURN TO SERVICE.					
Work Inspected By	MIKE MARTINEZ	Certificate No.	112468	Date	31-Mar-2020
Pertinent details of this maintenance are on file at our facility under the above Work/Service Order Number as applicable.					

Maintenance Log	
Book	Page



Maintenance Transaction Record

CAMP MTR ID # 3229889



This Maintenance Report is To Be Used Solely For (Check One)

Airframe Entries
 Eng. Serial No.
 Prop. Serial No.

Aircraft Identification and Status

A/C Serial #	A/C Unit #	A/C Registration #	Date	City ID	Total A/C Hours	Total A/C Landings	Total Engine Hrs	Total Engine Cycles	Total Prop Hrs			
208B-5098		RP-C1087	29-Jan-2020	RPLB	3608.9	6138	3608.9	6138	1284.1			

Component Changes, Inspections, Service Bulletins, or Airworthiness Directives Accomplished

Item	Transaction No.	Type	Item Name	Position	Part Number / Alternate Part	Mod Level	Part Serial	Removal Reason	Installed Part Status	TSN/TSO/TSR	Material Costs	Man Hours
5-15-08	1	2	INSPECTION DOCUMENT 08									
Comments:												

Trans Type: 1 - Component, 2 - Inspection, 3 - SB, 4 - AD, -- Misc.
 Removal Reasons: WO - Worn to Limits, SC - Scheduled, UN - Unscheduled, CO - Convenience, N - Other(note in comments)
 Installed Part Status: N - New, R - Repaired / Rebuilt, S - Serviceable, O - Overhauled, T - Tested, M - Modified, I - Inspected

Repair Facility	SUBIC	Certified Repair Station Number	135-14	Work Order No.	C200003A
Work Performed By	VINCENT TERO	Certificate No.	012697-AMT	Date	29-Jan-2020
I certify that the above stated maintenance and/or inspection was performed in accordance with the current regulations of the <input type="checkbox"/> Federal Aviation Administration <input checked="" type="checkbox"/> Other (Specify) CAAP and					
THE AIRCRAFT IDENTIFIED ABOVE IS PRESENTLY AIRWORTHY AND APPROVED FOR RETURN TO SERVICE.					
Work Inspected By	JASON DAYRIT	Certificate No.	102495	Date	29-Jan-2020
Pertinent details of this maintenance are on file at our facility under the above Work/Service Order Number as applicable.					

Maintenance Log	
Book	Page



Maintenance Transaction Record

CAMP MTR ID # 3224708



This Maintenance Report is To Be Used Solely For (Check One)

Airframe Entries
 Eng. Serial No.
 Prop. Serial No.

Aircraft Identification and Status

A/C Serial #	A/C Unit #	A/C Registration #	Date	City ID	Total A/C Hours	Total A/C Landings	Total Engine Hrs	Total Engine Cycles	Total Prop Hrs			
208B-5098		RP-C1087	05-Apr-2019	RPVM	3335.9	5645	3335.9	5645	3335.9			

Component Changes, Inspections, Service Bulletins, or Airworthiness Directives Accomplished

Item	Transaction No.	Type	Item Name	Position	Part Number / Alternate Part	Mod Level	Part Serial	Removal Reason	Status	Installed Part TSN/TSO/TSR	Material Costs	Man Hours
256015	1	1	REPLACE ELT BATTERY		452-0133		379163-035	WO	N	0 MTH 0 HRS		
EXPIRATION Date: 01-Nov-2023 Comments:												

Trans Type: 1 - Component, 2 - Inspection, 3 - SB, 4 - AD, -- Misc.
 Removal Reasons: WO - Worn to Limits, SC - Scheduled, UN - Unscheduled, CO - Convenience, N - Other(note in comments)
 Installed Part Status: N - New, R - Repaired / Rebuilt, S - Serviceable, O - Overhauled, T - Tested, M - Modified, I - Inspected

Repair Facility	SUBIC	Certified Repair Station Number	135-14	Work Order No.	C190045
Work Performed By	TOM PASTELERO	Certificate No.	126117	Date	05-Apr-2019
I certify that the above stated maintenance and/or inspection was performed in accordance with the current regulations of the <input type="checkbox"/> Federal Aviation Administration <input checked="" type="checkbox"/> Other (Specify) CAAP and					
THE AIRCRAFT IDENTIFIED ABOVE IS PRESENTLY AIRWORTHY AND APPROVED FOR RETURN TO SERVICE.					
Work Inspected By	NESTOR DERPO	Certificate No.	119184	Date	05-Apr-2019
Pertinent details of this maintenance are on file at our facility under the above Work/Service Order Number as applicable.					

Maintenance Log	
Book	Page



Maintenance Transaction Record

CAMP MTR ID # 2955222



This Maintenance Report is To Be Used Solely For (Check One)

Airframe Entries Eng. Serial No. PCE-VA0103 Prop. Serial No. BUA32866

Aircraft Identification and Status

A/C Serial #	A/C Unit #	A/C Registration #	Date	City ID	Total A/C Hours	Total A/C Landings	Total Engine Hrs	Total Engine Cycles	Total Prop Hrs			
208B-5098		RP-C1087	25-Nov-2018	RPVM	2809.5	4620	2809.5	4620	2809.5			

Component Changes, Inspections, Service Bulletins, or Airworthiness Directives Accomplished

Item	Transaction No.	Type	Item Name	Position	Part Number / Alternate Part	Mod Level	Part Serial	Removal Reason	Installed Part Status	TSN/TSO/TSR	Material Costs	Man Hours
------	-----------------	------	-----------	----------	------------------------------	-----------	-------------	----------------	-----------------------	-------------	----------------	-----------

5-15-08 1 2 INSPECTION DOCUMENT 08

Comments:

Trans Type: 1 - Component, 2 - Inspection, 3 - SB, 4 - AD, -- Misc. Removal Reasons: WO - Worn to Limits, SC - Scheduled, UN - Unscheduled, CO - Convenience, N - Other(note in comments) Installed Part Status: N - New, R - Repaired / Rebuilt, S - Serviceable, O - Overhauled, T - Tested, M - Modified, I - Inspected

Repair Facility _____	Certified Repair Station Number _____	Work Order No. <u>00022-2018</u>
Work Performed By <u>DAVE BANARES</u>	Certificate No. <u>114533-AMT</u>	Date <u>25-Nov-2018</u>
I certify that the above stated maintenance and/or inspection was performed in accordance with the current regulations of the		
<input type="checkbox"/> Federal Aviation Administration	<input checked="" type="checkbox"/> Other (Specify) _____	CAAP _____ and _____
THE AIRCRAFT IDENTIFIED ABOVE IS PRESENTLY AIRWORTHY AND APPROVED FOR RETURN TO SERVICE.		
Work Inspected By <u>NESTOR DERPO</u>	Certificate No. <u>119184-AMT</u>	Date <u>25-Nov-2018</u>
Pertinent details of this maintenance are on file at our facility under the above Work/Service Order Number as applicable.		

Maintenance Log	
Book	Page



Maintenance Transaction Record

CAMP MTR ID # 2955204



This Maintenance Report is To Be Used Solely For (Check One)

Airframe Entries
 Eng. Serial No. PCE-VA0103
 Prop. Serial No. BUA32866

Aircraft Identification and Status

A/C Serial #	A/C Unit #	A/C Registration #	Date	City ID	Total A/C Hours	Total A/C Landings	Total Engine Hrs	Total Engine Cycles	Total Prop Hrs			
208B-5098		RP-C1087	21-Nov-2018	RPVM	2795.9	4589	2795.9	4589	2795.9			

Component Changes, Inspections, Service Bulletins, or Airworthiness Directives Accomplished

Item	Transaction No.	Type	Item Name	Position	Part Number / Alternate Part	Mod Level	Part Serial	Removal Reason	Installed Part Status	TSN/TSO/TSR	Material Costs	Man Hours
057010	1	2	NO. 1 ENGINE - MINOR INSPECTION									
Comments:												
790090	2	2	NO. 1 ENGINE - GENERAL VISUAL INSPECTION CHIP DETECTOR FOR DEBRIS									
Comments:												
5-15-06	3	2	INSPECTION DOCUMENT 06									
Comments:												
733010	4	2	NO. 1 ENGINE - GENERAL VISUAL INSPECTION PNEUMATIC P3 FILTER DRAIN VALVE									
Comments:												
731095	5	2	NO. 1 ENGINE - DO A VISUAL INSPECTION OF THE FUELFILTER		3059779-01				NSN			
Comments:												

Trans Type: 1 - Component, 2 - Inspection, 3 - SB, 4 - AD, -- Misc.
 Removal Reasons: WO - Worn to Limits, SC - Scheduled, UN - Unscheduled, CO - Convenience, N - Other(note in comments)
 Installed Part Status: N - New, R - Repaired / Rebuilt, S - Serviceable, O - Overhauled, T - Tested, M - Modified, I - Inspected

Repair Facility _____	Certified Repair Station Number _____	Work Order No. <u>00020-2018</u>
Work Performed By <u>DAVE BANARES</u>	Certificate No. <u>114533-AMT</u>	Date <u>21-Nov-2018</u>
I certify that the above stated maintenance and/or inspection was performed in accordance with the current regulations of the <input type="checkbox"/> Federal Aviation Administration <input checked="" type="checkbox"/> Other (Specify) _____ CAAP _____ and THE AIRCRAFT IDENTIFIED ABOVE IS PRESENTLY AIRWORTHY AND APPROVED FOR RETURN TO SERVICE.		
Work Inspected By <u>NESTOR DERPO</u>	Certificate No. <u>119184-AMT</u>	Date <u>21-Nov-2018</u>
Pertinent details of this maintenance are on file at our facility under the above Work/Service Order Number as applicable.		

Maintenance Log	
Book	Page

This Maintenance Report is To Be Used Solely For (Check One)

Airframe Entries
 Eng. Serial No. PCE-VA0103
 Prop. Serial No. BUA32866

Aircraft Identification and Status

A/C Serial #	A/C Unit #	A/C Registration #	Date	City ID	Total A/C Hours	Total A/C Landings	Total Engine Hrs	Total Engine Cycles	Total Prop Hrs			
208B-5098		RP-C1087	12-Oct-2018	RPVM	2662.6	4307	2662.6	4307	2662.6			

Component Changes, Inspections, Service Bulletins, or Airworthiness Directives Accomplished

Item	Transaction No.	Type	Item Name	Position	Part Number / Alternate Part	Mod Level	Part Serial	Removal Reason	Installed Part Status	TSN/TSO/TSR	Material Costs	Man Hours
5-15-07	1	2	INSPECTION DOCUMENT 07									
Comments:												

Trans Type: 1 - Component, 2 - Inspection, 3 - SB, 4 - AD, -- Misc.
 Removal Reasons: WO - Worn to Limits, SC - Scheduled, UN - Unscheduled, CO - Convenience, N - Other(note in comments)
 Installed Part Status: N - New, R - Repaired / Rebuilt, S - Serviceable, O - Overhauled, T - Tested, M - Modified, I - Inspected

Repair Facility _____	Certified Repair Station Number _____	Work Order No. <u>00007-2018</u>	
Work Performed By <u>JESSEL TOM PASTELERO</u>	Certificate No. <u>126117-AMT</u>	Date <u>12-Oct-2018</u>	
I certify that the above stated maintenance and/or inspection was performed in accordance with the current regulations of the <input type="checkbox"/> Federal Aviation Administration <input checked="" type="checkbox"/> Other (Specify) _____ CAAP _____ and _____			
THE AIRCRAFT IDENTIFIED ABOVE IS PRESENTLY AIRWORTHY AND APPROVED FOR RETURN TO SERVICE.			
Work Inspected By <u>NESTOR DERPO</u>	Certificate No. <u>119184-AMT</u>	Date <u>12-Oct-2018</u>	
Pertinent details of this maintenance are on file at our facility under the above Work/Service Order Number as applicable.			

Maintenance Log	
Book	Page



AIRCRAFT WEIGHT AND BALANCE REPORT

WEIGHING REPORT

CLIENT/OWNER:	<u>AIR JUAN</u>	WORK ORDER NO.:	<u>S18523</u>
MAKE & MODEL:	<u>CESSNA CARAVAN 208B</u>	WEIGHED BY:	<u>ENGR. JENNIFER R. LINGAD</u>
REGISTRY MARK:	<u>RP-C1087</u>	DATE WEIGHED:	<u>01 OCTOBER 2018</u>
SERIAL NUMBER:	<u>208B5098</u>	PLACE WEIGHED:	<u>A.C.I. HANGAR, SUBIC BAY</u>

REACTIONS	SCALE READINGS (lb)	TARE (lb)	NET WEIGHT (lb)	ARM (in.)	MOMENT (lb-in.)
LEFT MAIN	2091.00	0.00	2091.00		
RIGHT MAIN	2216.00	0.00	2216.00		
SUB-TOTAL MAIN	4307.00	0.00	4307.00		
NOSE	835.67	0.00	835.67		
TOTAL WEIGHT (As Weighed)	5142.67	0.00	5142.67	190.11614	463437.25

ITEMS	NET WEIGHT (lb)	ARM (in.)	MOMENT (lb-in.)
TOTAL WEIGHT (as weighed)	5142.67	190.11614	463437.25
TOTAL WEIGHT OF ITEMS WEIGHED BUT NOT PART OF OPERATING EMPTY WEIGHT (-) (Details in attached COMPUTATIONS, Item II)	0.00	-	0.00
TOTAL WEIGHT OF ITEMS NOT WEIGHED BUT PART OF OPERATING EMPTY WEIGHT (+) (Details in attached COMPUTATIONS, Item III)	24.10	-	4974.24
OTHERS (+/-) (Details in attached COMPUTATIONS, Item IV)	-	-	0.00
NEW OPERATING EMPTY WEIGHT AND C.G.	5166.77	190.65853	468411.49

ILLUSTRATION

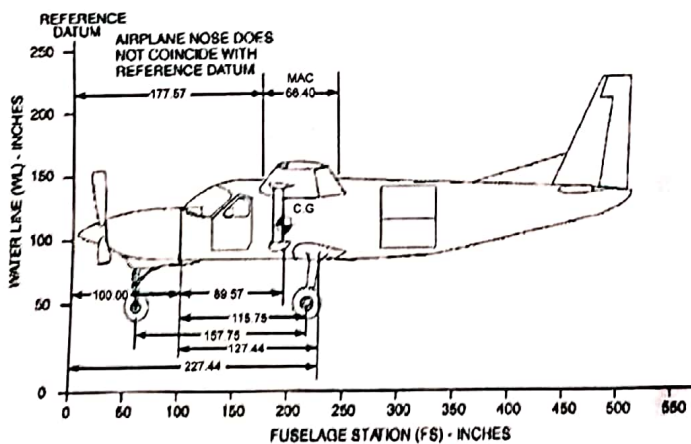

REMARKS:

- Aircraft condition when weighed:
 - Defueled up to undrainable fuel condition.
 - Oil tanks in normal operating level.
 - Clean and dry.
 - All access doors and cowlings installed – all doors closed.
- Weight reading is the average of three (3) trial readings.
- C.G. at Operating Empty Weight (468411.49 lb) – 190.65853 in. from datum.
- Empty Weight CG Range: Refer to approved POH.
- Weighing Equipment Used: GEC PN: AN60-6; Calibration due: 26 Oct 2018.
- References Used:
 - Cessna 208B Pilots Operating Handbook.
 - Previous Weight and Balance dated 17 Jun 2017.
 - RP-C1087 Weight and Balance Equipment Checklist.
 - Type Certificate Data Sheet No.A37CE Cessna 208B R.21 dated last 29 July 2015
- EEL items complete. 12 life vest on aircraft.
- Reference Datum during weighing is nose jacking point/front end firewall. Final C.G. arm is computed C.G. arm plus 100 in.:
 C.G. = 90.65853 in. + 100 in. = 190.65853 in.

CERTIFIED BY

Engr. Jennifer R. Lingad / Lic. 1429
 (Signature over printed name and license no.)
 Weighing Engineer

OBSERVER (If applicable)

Observer 1: Engr. Kevin P. Pangilinan
 (Signature over printed name)
 Observer 2: Engr. John M. Duad
 (Signature over printed name)



APPROVED MAINTENANCE ORGANIZATION 32-97

Hangar 7224 Clark International Airport
Clark Freeport Zone, Pampanga, Philippines 2023
Tel No.: (045) 599-2384 / Fax No.: (045) 599-2383

Form No.: DT-F-ENG-11
Revision No.: 00
Revision Date: 08 Feb 2017

AWB 007-18



AIRCRAFT WEIGHT AND BALANCE REPORT

READINGS

CLIENT/OWNER:	<u>AIR JUAN</u>	WORK ORDER NO.:	<u>S18523</u>
MAKE & MODEL:	<u>CESSNA CARAVAN 208B</u>	WEIGHED BY:	<u>ENGR. JENNIFER R. LINGAD</u>
REGISTRY MARK:	<u>RP-C1087</u>	DATE WEIGHED:	<u>01 OCTOBER 2018</u>
SERIAL NUMBER:	<u>208B5098</u>	PLACE WEIGHED:	<u>A.C.I. HANGAR, SUBIC BAY</u>

REACTION	1 ST READING (lb)	2 ND READING (lb)	3 RD READING (lb)	AVERAGE (lb)
LEFT MAIN	2091.00	2090.00	2092.00	2091.00
RIGHT MAIN	2215.00	2217.00	2216.00	2216.00
SUB-TOTAL MAIN	4306.00	4307.00	4308.00	4307.00
NOSE	834.00	837.00	836.00	835.67
TOTAL WEIGHT (AS WEIGHED)	5140.00	5144.00	5144.00	5142.67

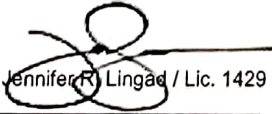
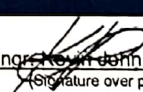
REACTION	SCALE READINGS (lb)	TARE (lb)	NET WEIGHT (lb)	ARM (in.)	MOMENT (lb · in.)
LEFT MAIN	2091.00	0.00	2091.00		
RIGHT MAIN	2216.00	0.00	2216.00		
SUB-TOTAL MAIN	4307.00	0.00	4307.00	115.7500	498535.25
NOSE	835.67	0.00	835.67	-42.0000	-35098.14
TOTAL WEIGHT	5142.67	0.00	5142.67	90.1161	463437.25

CERTIFIED BY	OBSERVER (If applicable)
 Engr. Jennifer R. Lingad / Lic. 1429 (Signature over printed name and license no.) Weighing Engineer	Observer 1:  Engr. Kevin P. Pangilinan (Signature over printed name) Observer 2:  Engr. Dan Keith M. Orad (Signature over printed name)

DISTRIBUTION COPY: Copy 1: Client/Owner Copy 2: Continuous Airworthiness Section Copy 3: CAAP - FSIS - AES



AIRCRAFT WEIGHT AND BALANCE REPORT

COMPUTATIONS

CLIENT/OWNER: AIR JUAN WORK ORDER NO.: S18523
 MAKE & MODEL: CESSNA CARAVAN 208B WEIGHED BY: ENGR. JENNIFER R. LINGAD
 REGISTRY MARK: RP-C1087 DATE WEIGHED: 01 OCTOBER 2018
 SERIAL NUMBER: 208B5098 PLACE WEIGHED: A.C.I. HANGAR, SUBIC BAY

ITEM	WEIGHT (lb)	ARM (in.)	MOMENT (lb-in.)
I. Total Weight (As weighed)	5142.67	90.12	463437.11
II. Items Weighed but not part of Operating Empty Weight	0.00	0.00	0.00
TOTAL:	5142.67	90.12	463437.11
III. Items not Weighed but part of Operating Empty Weight			
a) Drainable Unusable Fuel = Unusable – Undrainable	24.10	206.40	4974.24
TOTAL:	24.10	206.40	4974.24
IV. Others			
a) None	0.00	0.00	0.00
TOTAL:	0.00	0.00	0.00
FINAL OPERATING EMPTY WEIGHT	5166.77	90.6585	468411.49

IMPORTANT NOTES:



Position of the Forward Locking Pin of each passenger seat is as follows:
 First Row Passenger Seats Forward Locking Pin located at 173.5 in. from datum line.
 Second Row Passenger Seats Forward Locking Pin located at 213.5 in. from datum line.
 Third Row Passenger Seats Forward Locking Pin located at 255.5 in. from datum line.

Operating Empty Weight C.G. is 19.71% of M.A.C.

CERTIFIED BY

OBSERVER (If applicable)

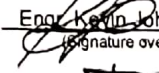
 Engr. Jennifer R. Lingad / Lic. 1429
 (Signature over printed name and license no.)
 Weighing Engineer

Observer 1:  Engr. Kevin John P. Pangilinan
 (Signature over printed name)
 Observer 2:  Engr. Dan Keith M. Bual
 (Signature over printed name)

DISTRIBUTION COPY: Copy 1: Client/Owner Copy 2: Continuous Airworthiness Section Copy 3: CAAP – FSIS - AES



APPROVED MAINTENANCE ORGANIZATION 32-97

Hangar 7224 Clark International Airport
Clark Freeport Zone, Pampanga, Philippines 2023
Tel No.: (045) 599-2384 / Fax No.: (045) 599-2383

Form No.: DT-F-ENG-11
Revision No.: 00
Revision Date: 08 Feb 2017

AWB 007-18

AIRCRAFT WEIGHT AND BALANCE REPORT

COMPUTATIONS

CLIENT/OWNER:	<u>AIR JUAN</u>	WORK ORDER NO.:	<u>S18523</u>
MAKE & MODEL:	<u>CESSNA CARAVAN 208B</u>	WEIGHED BY:	<u>ENGR. JENNIFER R. LINGAD</u>
REGISTRY MARK:	<u>RP-C1087</u>	DATE WEIGHED:	<u>01 OCTOBER 2018</u>
SERIAL NUMBER:	<u>208B5098</u>	PLACE WEIGHED:	<u>A.C.I. HANGAR, SUBIC BAY</u>

DESCRIPTION	STATUS	REMARKS
1. FUEL	DRAINED	DEFUELED UP TO DRAINABLE FUEL CONDITION
2. OIL	OPERATING LEVEL	NIL
3. EMERGENCY A. FIRE EXTINGUISHER B. MEDICAL KIT C. ELT D. LIFEVEST E. MEGAPHONE F. PBE	INSTALLED INSTALLED INSTALLED INSTALLED N/A N/A	12 LIFEVESTS ON BOARD
4. BATTERY	INSTALLED	NIL
5. AVIONICS EQUIPMENT	COMPLETE	NIL
6. TRIM A. SIDE PANELS B. WINDOWS C. CARPETS	INSTALLED INSTALLED INSTALLED	NIL
7. CONTROL SURFACES	NEUTRAL POSITION	NIL
8. FLAPS	FULLY RETRACTED	NIL
9. AIRCRAFT CONDITION	CLEAN	NIL
10. WATER/ METHANOL	N/A	NIL
11. HYDRAULIC	NORMAL OPERATING LEVEL	NIL
12. PASSENGER SEAT WITH SAFETY BELTS	INSTALLED	NIL

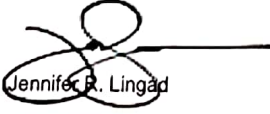
CHECKED & INSPECTED BY:		CONFIRMED BY:	
 _____ SIGNATURE OVER PRINTED NAME	01 Oct 2018 _____ DATE	_____ SIGNATURE OVER PRINTED NAME	_____ DATE

DISTRIBUTION COPY: Copy 1: Client/Owner Copy 2: Continuous Airworthiness Section Copy 3: CAAP - FSIS - AES



Maintenance Transaction Record

CAMP MTR ID # 2915343



This Maintenance Report is To Be Used Solely For (Check One)

Airframe Entries
 Eng. Serial No. PCE-VA0103
 Prop. Serial No. BUA32866

Aircraft Identification and Status

A/C Serial #	A/C Unit #	A/C Registration #	Date	City ID	Total A/C Hours	Total A/C Landings	Total Engine Hrs	Total Engine Cycles	Total Prop Hrs			
208B-5098		RP-C1087	20-Sep-2018	RPLB	2643.5	4262	2643.5	4262	2643.5			

Component Changes, Inspections, Service Bulletins, or Airworthiness Directives Accomplished

Item	Transaction No.	Type	Item Name	Position	Part Number / Alternate Part	Mod Level	Part Serial	Removal Reason	Installed Part Status	TSN/TSO/TSR	Material Costs	Man Hours
051001	1	2	RENEWAL AIRWORTHINESS									
Comments: RENEWED CERTIFICATE OF AIRWORTHINESS O.R. NO: A-1574514/17-09-18 CONTROL NO: 0004885 DATE ISSUED: 24 SEPTEMBER 2018 DATE OF EXPIRATION: 23 SEPTEMBER 2019												

Trans Type: 1 - Component, 2 - Inspection, 3 - SB, 4 - AD, -- Misc.
 Removal Reasons: WO - Worn to Limits, SC - Scheduled, UN - Unscheduled, CO - Convenience, N - Other(note in comments)
 Installed Part Status: N - New, R - Repaired / Rebuilt, S - Serviceable, O - Overhauled, T - Tested, M - Modified, I - Inspected

Repair Facility _____	Certified Repair Station Number _____	Work Order No. <u>S18513</u>
Work Performed By <u>JUSTINE GARCIA</u>	Certificate No. <u>136778-AMT</u>	Date <u>20-Sep-2018</u>
I certify that the above stated maintenance and/or inspection was performed in accordance with the current regulations of the <input type="checkbox"/> Federal Aviation Administration <input checked="" type="checkbox"/> Other (Specify) <u>CAAP</u> and _____		
THE AIRCRAFT IDENTIFIED ABOVE IS PRESENTLY AIRWORTHY AND APPROVED FOR RETURN TO SERVICE.		
Work Inspected By <u>ALLEN GABISON</u>	Certificate No. <u>110205-AMT</u>	Date <u>20-Sep-2018</u>
Pertinent details of this maintenance are on file at our facility under the above Work/Service Order Number as applicable.		

Maintenance Log	
Book	Page



Maintenance Transaction Record

CAMP MTR ID # 2916768



This Maintenance Report is To Be Used Solely For (Check One)

Airframe Entries
 Eng. Serial No. PCE-VA0103
 Prop. Serial No. BUA32866

Aircraft Identification and Status

A/C Serial #	A/C Unit #	A/C Registration #	Date	City ID	Total A/C Hours	Total A/C Landings	Total Engine Hrs	Total Engine Cycles	Total Prop Hrs			
208B-5098		RP-C1087	18-Sep-2018	RPLB	2615.5	4214	2615.5	4214	2615.5			

Component Changes, Inspections, Service Bulletins, or Airworthiness Directives Accomplished

Item	Transaction No.	Type	Item Name	Position	Part Number / Alternate Part	Mod Level	Part Serial	Removal Reason	Installed Part Status	TSN/TSO/TSR	Material Costs	Man Hours
B341103	1	2	CALIBRATION TEST STANDBY ALTIMETER STANDBY (FAR 91.411)		5934PAD-3DA,657		502525					
Comments: CARRIED OUT BY PEGASUS AIR SERVICES, INC. FOR REFERENCE CHECK CERT NO. 09182018-00240												
B341103	2	2	FUNCTION CHECK LEFT HAND PITOT/STATIC SYSTEM (91.411)	LEFT HAND								
Comments: CARRIED OUT BY PEGASUS AIR SERVICES, INC. FOR REFERENCE CHECK CERT NO. 09182018-00240												
B341103	3	2	FUNCTION CHECK RIGHT HAND PITOT/STATIC SYSTEM (91.411)	RIGHT HAND								
Comments: CARRIED OUT BY PEGASUS AIR SERVICES, INC. FOR REFERENCE CHECK CERT NO. 09182018-00240												

Trans Type: 1 - Component, 2 - Inspection, 3 - SB, 4 - AD, -- Misc.
 Removal Reasons: WO - Worn to Limits, SC - Scheduled, UN - Unscheduled, CO - Convenience, N - Other(note in comments)
 Installed Part Status: N - New, R - Repaired / Rebuilt, S - Serviceable, O - Overhauled, T - Tested, M - Modified, I - Inspected

Repair Facility _____	Certified Repair Station Number _____	Work Order No. _____
Work Performed By <u>PEGASUS AIR SERVICES, INC</u>	Certificate No. _____	Date <u>18-Sep-2018</u>
I certify that the above stated maintenance and/or inspection was performed in accordance with the current regulations of the <input type="checkbox"/> Federal Aviation Administration <input checked="" type="checkbox"/> Other (Specify) _____ CAAP _____ and _____		
THE AIRCRAFT IDENTIFIED ABOVE IS PRESENTLY AIRWORTHY AND APPROVED FOR RETURN TO SERVICE.		
Work Inspected By <u>NESTOR DERPO</u>	Certificate No. <u>119184-AMT</u>	Date <u>18-Sep-2018</u>
Pertinent details of this maintenance are on file at our facility under the above Work/Service Order Number as applicable.		

Maintenance Log	
Book	Page

This Maintenance Report is To Be Used Solely For (Check One)

Airframe Entries
 Eng. Serial No. PCE-VA0103
 Prop. Serial No. BUA32866

Aircraft Identification and Status

A/C Serial #	A/C Unit #	A/C Registration #	Date	City ID	Total A/C Hours	Total A/C Landings	Total Engine Hrs	Total Engine Cycles	Total Prop Hrs			
208B-5098		RP-C1087	10-Sep-2018	RPLB	2625.6	4233	2625.6	4233	2625.6			

Component Changes, Inspections, Service Bulletins, or Airworthiness Directives Accomplished

Item	Transaction No.	Type	Item Name	Position	Part Number / Alternate Part	Mod Level	Part Serial	Removal Reason	Status	Installed Part TSN/TSO/TSR	Material Costs	Man Hours
370102	1	1	VACUUM SYSTEM CENTRAL AIR FILTER DISCARD		AAD-9-18-1		NSN	SC	N	0 MTH 0 HRS		
Comments: Removed part no: AAD-9-18-1 Removed serial no: NSN.												
370103	2	1	VACUUM RELIEF VALVE FILTER DISCARD		C482001-0202		NSN	SC	N	0 MTH 0 HRS		
Comments: Removed part no: C482001-0202 Removed serial no: NSN.												

Trans Type: 1 - Component, 2 - Inspection, 3 - SB, 4 - AD, -- Misc.
 Removal Reasons: WO - Worn to Limits, SC - Scheduled, UN - Unscheduled, CO - Convenience, N - Other(note in comments)
 Installed Part Status: N - New, R - Repaired / Rebuilt, S - Serviceable, O - Overhauled, T - Tested, M - Modified, I - Inspected

Repair Facility _____	Certified Repair Station Number _____	Work Order No. <u>218494</u>	
Work Performed By <u>FREDERICK JOHN MALON</u>	Certificate No. <u>110092-AMT</u>	Date <u>10-Sep-2018</u>	
I certify that the above stated maintenance and/or inspection was performed in accordance with the current regulations of the <input type="checkbox"/> Federal Aviation Administration <input checked="" type="checkbox"/> Other (Specify) _____ CAAP _____ and _____			
THE AIRCRAFT IDENTIFIED ABOVE IS PRESENTLY AIRWORTHY AND APPROVED FOR RETURN TO SERVICE.			
Work Inspected By <u>ALLEN GABISON</u>	Certificate No. <u>110205-AMT</u>	Date <u>10-Sep-2018</u>	
Pertinent details of this maintenance are on file at our facility under the above Work/Service Order Number as applicable.			

Maintenance Log	
Book	Page



Maintenance Transaction Record

CAMP MTR ID # 2915362



This Maintenance Report is To Be Used Solely For (Check One)

Airframe Entries Eng. Serial No. PCE-VA0103 Prop. Serial No. BUA32866

Aircraft Identification and Status

A/C Serial #	A/C Unit #	A/C Registration #	Date	City ID	Total A/C Hours	Total A/C Landings	Total Engine Hrs	Total Engine Cycles	Total Prop Hrs			
208B-5098		RP-C1087	09-Sep-2018	RPLB	2623.1	4227	2623.1	4227	2623.1			

Component Changes, Inspections, Service Bulletins, or Airworthiness Directives Accomplished

Item	Transaction No.	Type	Item Name	Position	Part Number / Alternate Part	Mod Level	Part Serial	Removal Reason	Installed Part Status	TSN/TSO/TSR	Material Costs	Man Hours
------	-----------------	------	-----------	----------	------------------------------	-----------	-------------	----------------	-----------------------	-------------	----------------	-----------

051265 1 2 INSPECT 50 HR INSP-FLOATS

Comments:

Trans Type: 1 - Component, 2 - Inspection, 3 - SB, 4 - AD, -- Misc. Removal Reasons: WO - Worn to Limits, SC - Scheduled, UN - Unscheduled, CO - Convenience, N - Other(note in comments) Installed Part Status: N - New, R - Repaired / Rebuilt, S - Serviceable, O - Overhauled, T - Tested, M - Modified, I - Inspected

Repair Facility _____	Certified Repair Station Number _____	Work Order No. S18484
Work Performed By FREDERICK JOHN MALON	Certificate No. 110092-AMT	Date 09-Sep-2018
I certify that the above stated maintenance and/or inspection was performed in accordance with the current regulations of the		
<input type="checkbox"/> Federal Aviation Administration	<input checked="" type="checkbox"/> Other (Specify) CAAP	and
THE AIRCRAFT IDENTIFIED ABOVE IS PRESENTLY AIRWORTHY AND APPROVED FOR RETURN TO SERVICE.		
Work Inspected By ALLEN GABISON	Certificate No. 110205-AMT	Date 09-Sep-2018
Pertinent details of this maintenance are on file at our facility under the above Work/Service Order Number as applicable.		

Maintenance Log	
Book	Page

This Maintenance Report is To Be Used Solely For (Check One)

Airframe Entries
 Eng. Serial No. PCE-VA0103
 Prop. Serial No. BUA32866

Aircraft Identification and Status

A/C Serial #	A/C Unit #	A/C Registration #	Date	City ID	Total A/C Hours	Total A/C Landings	Total Engine Hrs	Total Engine Cycles	Total Prop Hrs			
208B-5098		RP-C1087	08-Sep-2018	RPLB	2623.1	4227	2623.1	4227	2623.1			

Component Changes, Inspections, Service Bulletins, or Airworthiness Directives Accomplished

Item	Transaction No.	Type	Item Name	Position	Part Number / Alternate Part	Mod Level	Part Serial	Removal Reason	Installed Part Status	TSN/TSO/TSR	Material Costs	Man Hours
051260	1	2	INSPECT 25 HR INSP-FLOATS									
Comments:												

Trans Type: 1 - Component, 2 - Inspection, 3 - SB, 4 - AD, -- Misc.
 Removal Reasons: WO - Worn to Limits, SC - Scheduled, UN - Unscheduled, CO - Convenience, N - Other(note in comments)
 Installed Part Status: N - New, R - Repaired / Rebuilt, S - Serviceable, O - Overhauled, T - Tested, M - Modified, I - Inspected

Repair Facility _____	Certified Repair Station Number _____	Work Order No. <u>S18484</u>	
Work Performed By <u>FREDERICK JOHN MALON</u>	Certificate No. <u>110092-AMT</u>	Date <u>08-Sep-2018</u>	
I certify that the above stated maintenance and/or inspection was performed in accordance with the current regulations of the <input type="checkbox"/> Federal Aviation Administration <input checked="" type="checkbox"/> Other (Specify) _____ CAAP _____ and _____			
THE AIRCRAFT IDENTIFIED ABOVE IS PRESENTLY AIRWORTHY AND APPROVED FOR RETURN TO SERVICE.			
Work Inspected By <u>ALLEN GABISON</u>	Certificate No. <u>110205-AMT</u>	Date <u>08-Sep-2018</u>	
Pertinent details of this maintenance are on file at our facility under the above Work/Service Order Number as applicable.			

Maintenance Log	
Book	Page

This Maintenance Report is To Be Used Solely For (Check One)

Airframe Entries
 Eng. Serial No. PCE-VA0103
 Prop. Serial No. BUA32866

Aircraft Identification and Status											
A/C Serial #	A/C Unit #	A/C Registration #	Date	City ID	Total A/C Hours	Total A/C Landings	Total Engine Hrs	Total Engine Cycles	Total Prop Hrs		
208B-5098		RP-C1087	05-Sep-2018	RPLB	2615.5	4212	2615.5	4212	2615.5		

Component Changes, Inspections, Service Bulletins, or Airworthiness Directives Accomplished											
Item	Transaction No.	Type	Item Name	Position	Part Number / Alternate Part	Mod Level	Part Serial	Removal Reason	Installed Part Status	Material TSN/TSO/TSR	Man Hours
5-15-20	1	2	INSPECTION DOCUMENT 20								
Comments: CARRIED OUT IAW C208B MAINTENANCE MANUAL. TASK 25-60-00-722. SATISFACTORY											
5-15-22	2	2	INSPECTION DOCUMENT 22 (PLEASE REFER TO INDIVIDUAL SUBTASKS FOR DUE TIMES)								
Comments: CARRIED OUT IAW C208B MAINTENANCE MANUAL. TASK 34-50-00-720. SATISFACTORY											

Trans Type: 1 - Component, 2 - Inspection, 3 - SB, 4 - AD, -- Misc.
 Removal Reasons: WO - Worn to Limits, SC - Scheduled, UN - Unscheduled, CO - Convenience, N - Other(note in comments)
 Installed Part Status: N - New, R - Repaired / Rebuilt, S - Serviceable, O - Overhauled, T - Tested, M - Modified, I - Inspected

Repair Facility _____	Certified Repair Station Number _____	Work Order No. <u>180090</u>	
Work Performed By <u>PEGASUS AIR SERVICE INC</u>	Certificate No. _____	Date <u>05-Sep-2018</u>	
I certify that the above stated maintenance and/or inspection was performed in accordance with the current regulations of the			
<input type="checkbox"/> Federal Aviation Administration <input checked="" type="checkbox"/> Other (Specify) _____ CAAP _____ and			
THE AIRCRAFT IDENTIFIED ABOVE IS PRESENTLY AIRWORTHY AND APPROVED FOR RETURN TO SERVICE.			
Work Inspected By <u>NESTOR DERPO</u>	Certificate No. <u>119184-AMT</u>	Date <u>05-Sep-2018</u>	
Pertinent details of this maintenance are on file at our facility under the above Work/Service Order Number as applicable.			

Maintenance Log	
Book	Page



Maintenance Transaction Record

CAMP MTR ID # 2915468



This Maintenance Report is To Be Used Solely For (Check One)

Airframe Entries Eng. Serial No. PCE-VA0103 Prop. Serial No. BUA32866

Aircraft Identification and Status

A/C Serial #	A/C Unit #	A/C Registration #	Date	City ID	Total A/C Hours	Total A/C Landings	Total Engine Hrs	Total Engine Cycles	Total Prop Hrs			
208B-5098		RP-C1087	28-Aug-2018	RPLB	2598.8	4187	2598.8	4187	2598.8			

Component Changes, Inspections, Service Bulletins, or Airworthiness Directives Accomplished

Item	Transaction No.	Type	Item Name	Position	Part Number / Alternate Part	Mod Level	Part Serial	Removal Reason	Installed Part Status	TSN/TSO/TSR	Material Costs	Man Hours
051270	1	2	INSPECT 100 HR INSP-FLOATS									
Comments:												

Trans Type: 1 - Component, 2 - Inspection, 3 - SB, 4 - AD, -- Misc. Removal Reasons: WO - Worn to Limits, SC - Scheduled, UN - Unscheduled, CO - Convenience, N - Other(note in comments) Installed Part Status: N - New, R - Repaired / Rebuilt, S - Serviceable, O - Overhauled, T - Tested, M - Modified, I - Inspected

Repair Facility _____	Certified Repair Station Number _____	Work Order No. S18477
Work Performed By FREDERICK JOHN MALON	Certificate No. 110092-AMT	Date 28-Aug-2018
I certify that the above stated maintenance and/or inspection was performed in accordance with the current regulations of the		
<input type="checkbox"/> Federal Aviation Administration	<input checked="" type="checkbox"/> Other (Specify) _____	CAAP _____ and _____
THE AIRCRAFT IDENTIFIED ABOVE IS PRESENTLY AIRWORTHY AND APPROVED FOR RETURN TO SERVICE.		
Work Inspected By ALLEN GABISON	Certificate No. 110205-AMT	Date 28-Aug-2018
Pertinent details of this maintenance are on file at our facility under the above Work/Service Order Number as applicable.		

Maintenance Log	
Book	Page



Maintenance Transaction Record

CAMP MTR ID # 2915345



This Maintenance Report is To Be Used Solely For (Check One)

Airframe Entries
 Eng. Serial No. PCE-VA0103
 Prop. Serial No. BUA32866

Aircraft Identification and Status

A/C Serial #	A/C Unit #	A/C Registration #	Date	City ID	Total A/C Hours	Total A/C Landings	Total Engine Hrs	Total Engine Cycles	Total Prop Hrs			
208B-5098		RP-C1087	28-Aug-2018	RPLB	2598.8	4187	2598.8	4187	2598.8			

Component Changes, Inspections, Service Bulletins, or Airworthiness Directives Accomplished

Item	Transaction No.	Type	Item Name	Position	Part Number / Alternate Part	Mod Level	Part Serial	Removal Reason	Installed Part Status	TSN/TSO/TSR	Material Costs	Man Hours
------	-----------------	------	-----------	----------	------------------------------	-----------	-------------	----------------	-----------------------	-------------	----------------	-----------

5-15-06 1 2 INSPECTION DOCUMENT 06

Comments:

Trans Type: 1 - Component, 2 - Inspection, 3 - SB, 4 - AD, -- Misc.

Removal Reasons: WO - Worn to Limits, SC - Scheduled, UN - Unscheduled, CO - Convenience, N - Other(note in comments)

Installed Part Status: N - New, R - Repaired / Rebuilt, S - Serviceable, O - Overhauled, T - Tested, M - Modified, I - Inspected

Repair Facility _____	Certified Repair Station Number _____	Work Order No. <u>S18476</u>
Work Performed By <u>ARIEL JAYSON DAYRIT</u>	Certificate No. <u>102495-AMT/AMS</u>	Date <u>28-Aug-2018</u>
<p>I certify that the above stated maintenance and/or inspection was performed in accordance with the current regulations of the</p> <p> <input type="checkbox"/> Federal Aviation Administration <input checked="" type="checkbox"/> Other (Specify) <u>CAAP</u> and </p> <p>THE AIRCRAFT IDENTIFIED ABOVE IS PRESENTLY AIRWORTHY AND APPROVED FOR RETURN TO SERVICE.</p>		
Work Inspected By <u>NESTOR DERPO</u>	Certificate No. <u>119184-AMT</u>	Date <u>28-Aug-2018</u>
<p>Pertinent details of this maintenance are on file at our facility under the above Work/Service Order Number as applicable.</p>		

Maintenance Log	
Book	Page

Maintenance Transaction Record

CAMP MTR ID # 2909662



This Maintenance Report is To Be Used Solely For (Check One)

Airframe Entries
 Eng. Serial No. PCE-VA0103
 Prop. Serial No. BUA32866

Aircraft Identification and Status

A/C Serial #	A/C Unit #	A/C Registration #	Date	City ID	Total A/C Hours	Total A/C Landings	Total Engine Hrs	Total Engine Cycles	Total Prop Hrs			
208B-5098		RP-C1087	08-Jun-2018	RPLB	2411.3	3755	2411.3	3755	2411.3			

Component Changes, Inspections, Service Bulletins, or Airworthiness Directives Accomplished

Item	Transaction No.	Type	Item Name	Position	Part Number / Alternate Part	Mod Level	Part Serial	Removal Reason	Installed Part Status	TSN/TSO/TSR	Material Costs	Man Hours
5-15-10	1	2	INSPECTION DOCUMENT 10									
Comments: CARRIED OUT INSPECTION IAW C208B MAINTENANCE MANUAL CH. 5-15. SATISFACTORY												
5-15-08	2	2	INSPECTION DOCUMENT 08									
Comments: CARRIED OUT INSPECTION IAW C208B MAINTENANCE MANUAL CH. 5-15. SATISFACTORY												

Trans Type: 1 - Component, 2 - Inspection, 3 - SB, 4 - AD, -- Misc.
 Removal Reasons: WO - Worn to Limits, SC - Scheduled, UN - Unscheduled, CO - Convenience, N - Other (note in comments)
 Installed Part Status: N - New, R - Repaired / Rebuilt, S - Serviceable, O - Overhauled, T - Tested, M - Modified, I - Inspected

Repair Facility _____	Certified Repair Station Number _____	Work Order No. <u>180060</u>
Work Performed By <u>FREDERICK JOHN MALON</u>	Certificate No. <u>110092-AMT</u>	Date <u>08-Jun-2018</u>
I certify that the above stated maintenance and/or inspection was performed in accordance with the current regulations of the <input type="checkbox"/> Federal Aviation Administration <input checked="" type="checkbox"/> Other (Specify) <u>CAAP</u> and _____		
THE AIRCRAFT IDENTIFIED ABOVE IS PRESENTLY AIRWORTHY AND APPROVED FOR RETURN TO SERVICE.		
Work Inspected By <u>NESTOR DERPO</u>	Certificate No. <u>119184-AMT</u>	Date <u>08-Jun-2018</u>
Pertinent details of this maintenance are on file at our facility under the above Work/Service Order Number as applicable.		

Maintenance Log	
Book	Page

Maintenance Transaction Record

CAMP MTR ID # 2910303

This Maintenance Report is To Be Used Solely For (Check One)

Airframe Entries
 Eng. Serial No. PCE-VA0103
 Prop. Serial No. BUA32866

Aircraft Identification and Status

A/C Serial #	A/C Unit #	A/C Registration #	Date	City ID	Total A/C Hours	Total A/C Landings	Total Engine Hrs	Total Engine Cycles	Total Prop Hrs			
208B-5098		RP-C1087	31-May-2018	RPLB	2385.6	3709	2385.6	3709	2385.6			

Component Changes, Inspections, Service Bulletins, or Airworthiness Directives Accomplished

Item	Transaction No.	Type	Item Name	Position	Part Number / Alternate Part	Mod Level	Part Serial	Removal Reason	Installed Part Status	TSN/TSO/TSR	Material Costs	Man Hours
790060	1	2	NO. 1 ENGINE - INSPECT AND CLEAN OIL FILTER ELEMENT FOR DEBRIS Comments:									
731096	2	1	NO. 1 ENGINE - OIL HEAT EXCHANGER FUEL FILTER ELEMENT Comments:		3059779-01		NSN	SC	N	0 HRS		
5-15-06	3	2	INSPECTION DOCUMENT 06 Comments:									

Trans Type: 1 - Component, 2 - Inspection, 3 - SB, 4 - AD, -- Misc.
 Removal Reasons: WO - Worn to Limits, SC - Scheduled, UN - Unscheduled, CO - Convenience, N - Other(note in comments)
 Installed Part Status: N - New, R - Repaired / Rebuilt, S - Serviceable, O - Overhauled, T - Tested, M - Modified, I - Inspected

Repair Facility	Certified Repair Station Number	Work Order No.	180052
Work Performed By	FREDERICK JOHN MALON	Certificate No.	110092-AMT Date 31-May-2018
I certify that the above stated maintenance and/or inspection was performed in accordance with the current regulations of the <input type="checkbox"/> Federal Aviation Administration <input checked="" type="checkbox"/> Other (Specify) <u>CAAP</u> and			
THE AIRCRAFT IDENTIFIED ABOVE IS PRESENTLY AIRWORTHY AND APPROVED FOR RETURN TO SERVICE.			
Work Inspected By	NESTOR DERPO	Certificate No.	119184-AMT Date 31-May-2018
Pertinent details of this maintenance are on file at our facility under the above Work/Service Order Number as applicable.			

Maintenance Log	
Book	Page



Maintenance Transaction Record

CAMP MTR ID # 2915337



This Maintenance Report is To Be Used Solely For (Check One)

Airframe Entries Eng. Serial No. PCE-VA0103 Prop. Serial No. BUA32866

Aircraft Identification and Status

A/C Serial #	A/C Unit #	A/C Registration #	Date	City ID	Total A/C Hours	Total A/C Landings	Total Engine Hrs	Total Engine Cycles	Total Prop Hrs			
208B-5098		RP-C1087	22-May-2018	RPLB	2358.1	3654	2358.1	3654	2358.1			

Component Changes, Inspections, Service Bulletins, or Airworthiness Directives Accomplished

Item	Transaction No.	Type	Item Name	Position	Part Number / Alternate Part	Mod Level	Part Serial	Removal Reason	Installed Part Status	TSN/TSO/TSR	Material Costs	Man Hours
053417	1	2	UPDATE NAV DATABASE									
Comments: PERFORMED NAV DATABASE UPDATE IAW G1000 INTRIGATED FLIGHT DECK. SECTION APPENDIX B REV. A PG.584 TO 587. SATISFACTORY												

Trans Type: 1 - Component, 2 - Inspection, 3 - SB, 4 - AD, -- Misc. Removal Reasons: WO - Worn to Limits, SC - Scheduled, UN - Unscheduled, CO - Convenience, N - Other(note in comments) Installed Part Status: N - New, R - Repaired / Rebuilt, S - Serviceable, O - Overhauled, T - Tested, M - Modified, I - Inspected

Repair Facility _____	Certified Repair Station Number _____	Work Order No. 180049
Work Performed By ARIEL JAYSON DAYRIT	Certificate No. 102495-AMT/AMS	Date 22-May-2018
I certify that the above stated maintenance and/or inspection was performed in accordance with the current regulations of the		
<input type="checkbox"/> Federal Aviation Administration <input checked="" type="checkbox"/> Other (Specify) CAAP _____ and		
THE AIRCRAFT IDENTIFIED ABOVE IS PRESENTLY AIRWORTHY AND APPROVED FOR RETURN TO SERVICE.		
Work Inspected By NESTOR DERPO	Certificate No. 119184-AMT	Date 22-May-2018
Pertinent details of this maintenance are on file at our facility under the above Work/Service Order Number as applicable.		

Maintenance Log	
Book	Page



Maintenance Transaction Record

CAMP MTR ID # 2908032



This Maintenance Report is To Be Used Solely For (Check One)

Airframe Entries Eng. Serial No. PCE-VA0103 Prop. Serial No. BUA32866

Aircraft Identification and Status

A/C Serial #	A/C Unit #	A/C Registration #	Date	City ID	Total A/C Hours	Total A/C Landings	Total Engine Hrs	Total Engine Cycles	Total Prop Hrs			
208B-5098		RP-C1087	30-Apr-2018	RPLB	2280.2	3514	2280.2	3514	2280.2			

Component Changes, Inspections, Service Bulletins, or Airworthiness Directives Accomplished

Item	Transaction No.	Type	Item Name	Position	Part Number / Alternate Part	Mod Level	Part Serial	Removal Reason	Installed Part Status	TSN/TSO/TSR	Material Costs	Man Hours
051280	1	2	INSPECTION ANNUAL FLOAT									
Comments: CARRIED OUT ANNUAL FLOAT INSPECTION IAW WIPAIRE 8750 FLOATS SERVICE MANUAL W8750-24-01. FOUND SATISFACTORY												

Trans Type: 1 - Component, 2 - Inspection, 3 - SB, 4 - AD, -- Misc. Removal Reasons: WO - Worn to Limits, SC - Scheduled, UN - Unscheduled, CO - Convenience, N - Other(note in comments) Installed Part Status: N - New, R - Repaired / Rebuilt, S - Serviceable, O - Overhauled, T - Tested, M - Modified, I - Inspected

Repair Facility _____	Certified Repair Station Number _____	Work Order No. 180031
Work Performed By VICTOR IAN PAULO DIONGLAY	Certificate No. 133864-AMT	Date 30-Apr-2018
I certify that the above stated maintenance and/or inspection was performed in accordance with the current regulations of the		
<input type="checkbox"/> Federal Aviation Administration <input checked="" type="checkbox"/> Other (Specify) CAAP _____ and		
THE AIRCRAFT IDENTIFIED ABOVE IS PRESENTLY AIRWORTHY AND APPROVED FOR RETURN TO SERVICE.		
Work Inspected By NESTOR DERPO	Certificate No. 119184-AMT	Date 30-Apr-2018
Pertinent details of this maintenance are on file at our facility under the above Work/Service Order Number as applicable.		

Maintenance Log	
Book	Page



Maintenance Transaction Record

CAMP MTR ID # 2909667



This Maintenance Report is To Be Used Solely For (Check One)

Airframe Entries Eng. Serial No. PCE-VA0103 Prop. Serial No. BUA32866

Aircraft Identification and Status

A/C Serial #	A/C Unit #	A/C Registration #	Date	City ID	Total A/C Hours	Total A/C Landings	Total Engine Hrs	Total Engine Cycles	Total Prop Hrs			
208B-5098		RP-C1087	30-Apr-2018	RPLB	2280.2	3514	2280.2	3514	2280.2			

Component Changes, Inspections, Service Bulletins, or Airworthiness Directives Accomplished

Item	Transaction No.	Type	Item Name	Position	Part Number / Alternate Part	Mod Level	Part Serial	Removal Reason	Installed Part Status	TSN/TSO/TSR	Material Costs	Man Hours
5-15-07	1	2	INSPECTION DOCUMENT 07									
Comments: CARRIED OUT INSPECTION DOCUMENT IAW C208B MAINTENANCE MANUAL CH 5-15. SATISFACTORY												

Trans Type: 1 - Component, 2 - Inspection, 3 - SB, 4 - AD, -- Misc. Removal Reasons: WO - Worn to Limits, SC - Scheduled, UN - Unscheduled, CO - Convenience, N - Other(note in comments) Installed Part Status: N - New, R - Repaired / Rebuilt, S - Serviceable, O - Overhauled, T - Tested, M - Modified, I - Inspected

Repair Facility _____	Certified Repair Station Number _____	Work Order No. 180031
Work Performed By ERIC DE LEON	Certificate No. 110359-AMT	Date 30-Apr-2018
I certify that the above stated maintenance and/or inspection was performed in accordance with the current regulations of the		
<input type="checkbox"/> Federal Aviation Administration	<input checked="" type="checkbox"/> Other (Specify) CAAP	and
THE AIRCRAFT IDENTIFIED ABOVE IS PRESENTLY AIRWORTHY AND APPROVED FOR RETURN TO SERVICE.		
Work Inspected By NESTOR DERPO	Certificate No. 119184-AMT	Date 30-Apr-2018
Pertinent details of this maintenance are on file at our facility under the above Work/Service Order Number as applicable.		

Maintenance Log	
Book	Page



Maintenance Transaction Record

CAMP MTR ID # 2915334



This Maintenance Report is To Be Used Solely For (Check One)

Airframe Entries Eng. Serial No. PCE-VA0103 Prop. Serial No. BUA32866

Aircraft Identification and Status

A/C Serial #	A/C Unit #	A/C Registration #	Date	City ID	Total A/C Hours	Total A/C Landings	Total Engine Hrs	Total Engine Cycles	Total Prop Hrs			
208B-5098		RP-C1087	24-Apr-2018	RPLB	2251.3	3463	2251.3	3463	2251.3			

Component Changes, Inspections, Service Bulletins, or Airworthiness Directives Accomplished

Item	Transaction No.	Type	Item Name	Position	Part Number / Alternate Part	Mod Level	Part Serial	Removal Reason	Installed Part Status	TSN/TSO/TSR	Material Costs	Man Hours
053417	1	2	UPDATE NAV DATABASE									
Comments: PERFORMED NAV DATABASE UPDATE IAW G1000 INTRIGATED FLIGHT DECK. SECTION APPENDIX B REV. A PG.584 TO 587. SATISFACTORY CYCLE: 1805												

Trans Type: 1 - Component, 2 - Inspection, 3 - SB, 4 - AD, -- Misc. Removal Reasons: WO - Worn to Limits, SC - Scheduled, UN - Unscheduled, CO - Convenience, N - Other(note in comments) Installed Part Status: N - New, R - Repaired / Rebuilt, S - Serviceable, O - Overhauled, T - Tested, M - Modified, I - Inspected

Repair Facility _____	Certified Repair Station Number _____	Work Order No. 180028
Work Performed By ARIEL JAYSON DAYRIT	Certificate No. 102495-AMT/AMS	Date 24-Apr-2018
I certify that the above stated maintenance and/or inspection was performed in accordance with the current regulations of the		
<input type="checkbox"/> Federal Aviation Administration	<input checked="" type="checkbox"/> Other (Specify) CAAP	and
THE AIRCRAFT IDENTIFIED ABOVE IS PRESENTLY AIRWORTHY AND APPROVED FOR RETURN TO SERVICE.		
Work Inspected By NESTOR DERPO	Certificate No. 119184-AMT	Date 24-Apr-2018
Pertinent details of this maintenance are on file at our facility under the above Work/Service Order Number as applicable.		

Maintenance Log	
Book	Page



Maintenance Transaction Record

CAMP MTR ID # 2909665



This Maintenance Report is To Be Used Solely For (Check One)

Airframe Entries Eng. Serial No. PCE-VA0103 Prop. Serial No. BUA32866

Aircraft Identification and Status

A/C Serial #	A/C Unit #	A/C Registration #	Date	City ID	Total A/C Hours	Total A/C Landings	Total Engine Hrs	Total Engine Cycles	Total Prop Hrs			
208B-5098		RP-C1087	11-Apr-2018	RPLB	2199	3369	2199	3369	2199			

Component Changes, Inspections, Service Bulletins, or Airworthiness Directives Accomplished

Item	Transaction No.	Type	Item Name	Position	Part Number / Alternate Part	Mod Level	Part Serial	Removal Reason	Installed Part Status	TSN/TSO/TSR	Material Costs	Man Hours
5-15-06	1	2	INSPECTION DOCUMENT 06									
Comments: CARRIED OUT INSP DOC IAW C208B MAINT MANUAL. CH 5-15. SATISFACTORY												

Trans Type: 1 - Component, 2 - Inspection, 3 - SB, 4 - AD, -- Misc. Removal Reasons: WO - Worn to Limits, SC - Scheduled, UN - Unscheduled, CO - Convenience, N - Other(note in comments) Installed Part Status: N - New, R - Repaired / Rebuilt, S - Serviceable, O - Overhauled, T - Tested, M - Modified, I - Inspected

Repair Facility _____	Certified Repair Station Number _____	Work Order No. 180023
Work Performed By ALLEN GABISON	Certificate No. 110205-AMT	Date 11-Apr-2018
I certify that the above stated maintenance and/or inspection was performed in accordance with the current regulations of the		
<input type="checkbox"/> Federal Aviation Administration	<input checked="" type="checkbox"/> Other (Specify) CAAP	and
THE AIRCRAFT IDENTIFIED ABOVE IS PRESENTLY AIRWORTHY AND APPROVED FOR RETURN TO SERVICE.		
Work Inspected By NESTOR DERPO	Certificate No. 119184-AMT	Date 11-Apr-2018
Pertinent details of this maintenance are on file at our facility under the above Work/Service Order Number as applicable.		

Maintenance Log	
Book	Page



Maintenance Transaction Record

CAMP MTR ID # 2909755



This Maintenance Report is To Be Used Solely For (Check One)

Airframe Entries Eng. Serial No. PCE-VA0103 Prop. Serial No. BUA32866

Aircraft Identification and Status

A/C Serial #	A/C Unit #	A/C Registration #	Date	City ID	Total A/C Hours	Total A/C Landings	Total Engine Hrs	Total Engine Cycles	Total Prop Hrs			
208B-5098		RP-C1087	10-Apr-2018	RPLB	2193.9	3361	2193.9	3361	2193.9			

Component Changes, Inspections, Service Bulletins, or Airworthiness Directives Accomplished

Item	Transaction No.	Type	Item Name	Position	Part Number / Alternate Part	Mod Level	Part Serial	Removal Reason	Installed Part Status	TSN/TSO/TSR	Material Costs	Man Hours
CAB-34-03	1	3	NAVIGATION - GARMIN G 1000 SYSTEM SOFTWARE UPGRADE TO VERSION 0767.23, SERVICE BULLETIN									
MOC: DECLINED Comments:												

Trans Type: 1 - Component, 2 - Inspection, 3 - SB, 4 - AD, -- Misc. Removal Reasons: WO - Worn to Limits, SC - Scheduled, UN - Unscheduled, CO - Convenience, N - Other(note in comments) Installed Part Status: N - New, R - Repaired / Rebuilt, S - Serviceable, O - Overhauled, T - Tested, M - Modified, I - Inspected

Repair Facility _____	Certified Repair Station Number _____	Work Order No. 180020
Work Performed By ARIEL JAYSON DAYRIT	Certificate No. 102495-AMT	Date 10-Apr-2018
I certify that the above stated maintenance and/or inspection was performed in accordance with the current regulations of the		
<input type="checkbox"/> Federal Aviation Administration	<input checked="" type="checkbox"/> Other (Specify) CAAP	and
THE AIRCRAFT IDENTIFIED ABOVE IS PRESENTLY AIRWORTHY AND APPROVED FOR RETURN TO SERVICE.		
Work Inspected By NESTOR DERPO	Certificate No. 119184-AMT	Date 10-Apr-2018
Pertinent details of this maintenance are on file at our facility under the above Work/Service Order Number as applicable.		

Maintenance Log	
Book	Page

Maintenance Transaction Record

CAMP MTR ID # 2910774

This Maintenance Report is To Be Used Solely For (Check One)

Airframe Entries
 Eng. Serial No. PCE-VA0103
 Prop. Serial No. BUA32866

Aircraft Identification and Status

A/C Serial #	A/C Unit #	A/C Registration #	Date	City ID	Total A/C Hours	Total A/C Landings	Total Engine Hrs	Total Engine Cycles	Total Prop Hrs			
208B-5098		RP-C1087	06-Apr-2018	RPLB	2172.9	3331	2172.9	3331	2172.9			

Component Changes, Inspections, Service Bulletins, or Airworthiness Directives Accomplished

Item	Transaction No.	Type	Item Name	Position	Part Number / Alternate Part	Mod Level	Part Serial	Removal Reason	Status	Installed Part TSN/TSO/TSR	Material Costs	Man Hours
370102	1	1	VACUUM SYSTEM CENTRAL AIR FILTER DISCARD Comments: Removed part no: AAD-9-18-1 Removed serial no: NSN.		AAD-9-18-1		NSN	SC	N	0 MTH 0 HRS		
370103	2	1	VACUUM RELIEF VALVE FILTER DISCARD Comments: Removed part no: C482001-0202 Removed serial no: NSN.		C482001-0202		NSN	SC	N	0 MTH 0 HRS		

Trans Type: 1 - Component, 2 - Inspection, 3 - SB, 4 - AD, -- Misc.
 Removal Reasons: WO - Worn to Limits, SC - Scheduled, UN - Unscheduled, CO - Convenience, N - Other(note in comments)
 Installed Part Status: N - New, R - Repaired / Rebuilt, S - Serviceable, O - Overhauled, T - Tested, M - Modified, I - Inspected

Repair Facility _____	Certified Repair Station Number _____	Work Order No. _____
Work Performed By ALLEN GABISON	Certificate No. 110205-AMT	Date 06-Apr-2018
I certify that the above stated maintenance and/or inspection was performed in accordance with the current regulations of the <input type="checkbox"/> Federal Aviation Administration <input checked="" type="checkbox"/> Other (Specify) _____ CAAP _____ and THE AIRCRAFT IDENTIFIED ABOVE IS PRESENTLY AIRWORTHY AND APPROVED FOR RETURN TO SERVICE.		
Work Inspected By NESTOR DERPO	Certificate No. 119184-AMT	Date 06-Apr-2018
Pertinent details of this maintenance are on file at our facility under the above Work/Service Order Number as applicable.		

Maintenance Log	
Book	Page



Maintenance Transaction Record

CAMP MTR ID # 2907581



This Maintenance Report is To Be Used Solely For (Check One)

Airframe Entries
 Eng. Serial No. PCE-VA0103
 Prop. Serial No. BUA32866

Aircraft Identification and Status

A/C Serial #	A/C Unit #	A/C Registration #	Date	City ID	Total A/C Hours	Total A/C Landings	Total Engine Hrs	Total Engine Cycles	Total Prop Hrs			
208B-5098		RP-C1087	29-Mar-2018	RPLB	2147	3286	2147	3286	2147			

Component Changes, Inspections, Service Bulletins, or Airworthiness Directives Accomplished

Item	Transaction No.	Type	Item Name	Position	Part Number / Alternate Part	Mod Level	Part Serial	Removal Reason	Installed Part Status	TSN/TSO/TSR	Material Costs	Man Hours
5-15-01	1	2	INSPECTION DOCUMENT 01									
Comments: CARRIED OUT INSPECTION DOCUMENT IN ACCORDANCE WITH C208B AIRCRAFT MAINTENANCE MANUAL CH. 5-15-01. SATISFACTORY												
5-15-02	2	2	INSPECTION DOCUMENT 02									
Comments: CARRIED OUT INSPECTION DOCUMENT IN ACCORDANCE WITH C208B AIRCRAFT MAINTENANCE MANUAL CH. 5-15-02. SATISFACTORY												
5-15-03	3	2	INSPECTION DOCUMENT 03									
Comments: CARRIED OUT INSPECTION DOCUMENT IN ACCORDANCE WITH C208B AIRCRAFT MAINTENANCE MANUAL CH. 5-15-03. SATISFACTORY												
5-15-09	4	2	INSPECTION DOCUMENT 09									
Comments: CARRIED OUT INSPECTION DOCUMENT IN ACCORDANCE WITH C208B AIRCRAFT MAINTENANCE MANUAL CH. 5-15-09. SATISFACTORY												
5-15-11	5	2	INSPECTION DOCUMENT 11									
Comments: CARRIED OUT INSPECTION DOCUMENT IN ACCORDANCE WITH C208B AIRCRAFT MAINTENANCE MANUAL CH. 5-15-11. SATISFACTORY												

Trans Type: 1 - Component, 2 - Inspection, 3 - SB, 4 - AD, -- Misc.
 Removal Reasons: WO - Worn to Limits, SC - Scheduled, UN - Unscheduled, CO - Convenience, N - Other(note in comments)
 Installed Part Status: N - New, R - Repaired / Rebuilt, S - Serviceable, O - Overhauled, T - Tested, M - Modified, I - Inspected

Repair Facility	Certified Repair Station Number	Work Order No.	180019
Work Performed By	Certificate No.	Date	29-Mar-2018
I certify that the above stated maintenance and/or inspection was performed in accordance with the current regulations of the <input type="checkbox"/> Federal Aviation Administration <input checked="" type="checkbox"/> Other (Specify) <u>CAAP</u> and			
THE AIRCRAFT IDENTIFIED ABOVE IS PRESENTLY AIRWORTHY AND APPROVED FOR RETURN TO SERVICE.			
Work Inspected By	Certificate No.	Date	29-Mar-2018
Pertinent details of this maintenance are on file at our facility under the above Work/Service Order Number as applicable.			

Maintenance Log	
Book	Page



Maintenance Transaction Record

CAMP MTR ID # 2915331



This Maintenance Report is To Be Used Solely For (Check One)

Airframe Entries Eng. Serial No. PCE-VA0103 Prop. Serial No. BUA32866

Aircraft Identification and Status

A/C Serial #	A/C Unit #	A/C Registration #	Date	City ID	Total A/C Hours	Total A/C Landings	Total Engine Hrs	Total Engine Cycles	Total Prop Hrs			
208B-5098		RP-C1087	27-Mar-2018	RPLB	2138.8	3274	2138.8	3274	2138.8			

Component Changes, Inspections, Service Bulletins, or Airworthiness Directives Accomplished

Item	Transaction No.	Type	Item Name	Position	Part Number / Alternate Part	Mod Level	Part Serial	Removal Reason	Installed Part Status	TSN/TSO/TSR	Material Costs	Man Hours
053417	1	2	UPDATE NAV DATABASE									
Comments: PERFORMED NAV DATABASE UPDATE IAW G1000 INTRIGATED FLIGHT DECK. SECTION APPENDIX B REV. A PG.584 TO 587. SATISFACTORY												
CYCLE: 1804												

Trans Type: 1 - Component, 2 - Inspection, 3 - SB, 4 - AD, -- Misc. Removal Reasons: WO - Worn to Limits, SC - Scheduled, UN - Unscheduled, CO - Convenience, N - Other(note in comments) Installed Part Status: N - New, R - Repaired / Rebuilt, S - Serviceable, O - Overhauled, T - Tested, M - Modified, I - Inspected

Repair Facility _____	Certified Repair Station Number _____	Work Order No. 180019
Work Performed By ARIEL JAYSON DAYRIT	Certificate No. 102495-AMT/AMS	Date 27-Mar-2018
I certify that the above stated maintenance and/or inspection was performed in accordance with the current regulations of the		
<input type="checkbox"/> Federal Aviation Administration <input checked="" type="checkbox"/> Other (Specify) CAAP _____ and		
THE AIRCRAFT IDENTIFIED ABOVE IS PRESENTLY AIRWORTHY AND APPROVED FOR RETURN TO SERVICE.		
Work Inspected By NESTOR DERPO	Certificate No. 119184-AMT	Date 27-Mar-2018
Pertinent details of this maintenance are on file at our facility under the above Work/Service Order Number as applicable.		

Maintenance Log	
Book	Page



Maintenance Transaction Record

CAMP MTR ID # 2915104



This Maintenance Report is To Be Used Solely For (Check One)

Airframe Entries
 Eng. Serial No. PCE-VA0103
 Prop. Serial No. BUA32866

Aircraft Identification and Status

A/C Serial #	A/C Unit #	A/C Registration #	Date	City ID	Total A/C Hours	Total A/C Landings	Total Engine Hrs	Total Engine Cycles	Total Prop Hrs			
208B-5098		RP-C1087	27-Feb-2018	RPLB	2083.9	3134	2083.9	3134	2083.9			

Component Changes, Inspections, Service Bulletins, or Airworthiness Directives Accomplished

Item	Transaction No.	Type	Item Name	Position	Part Number / Alternate Part	Mod Level	Part Serial	Removal Reason	Installed Part Status	TSN/TSO/TSR	Material Costs	Man Hours
053417	1	2	UPDATE NAV DATABASE									
Comments: PERFORMED NAV DATABASE UPDATE IAW G1000 INTRIGATED FLIGHT DECK. SECTION APPENDIX B REV. A PG.584 TO 587. SATISFACTORY CYCLE:1803												

Trans Type: 1 - Component, 2 - Inspection, 3 - SB, 4 - AD, -- Misc.
 Removal Reasons: WO - Worn to Limits, SC - Scheduled, UN - Unscheduled, CO - Convenience, N - Other(note in comments)
 Installed Part Status: N - New, R - Repaired / Rebuilt, S - Serviceable, O - Overhauled, T - Tested, M - Modified, I - Inspected

Repair Facility	Certified Repair Station Number	Work Order No.	180015
Work Performed By	ARIEL JAYSON DAYRIT	Certificate No.	102495-AMT/AMS
		Date	27-Feb-2018
I certify that the above stated maintenance and/or inspection was performed in accordance with the current regulations of the			
<input type="checkbox"/> Federal Aviation Administration <input checked="" type="checkbox"/> Other (Specify) <u>CAAP</u> and			
THE AIRCRAFT IDENTIFIED ABOVE IS PRESENTLY AIRWORTHY AND APPROVED FOR RETURN TO SERVICE.			
Work Inspected By	NESTOR DERPO	Certificate No.	119184-AMT
		Date	27-Feb-2018
Pertinent details of this maintenance are on file at our facility under the above Work/Service Order Number as applicable.			

Maintenance Log	
Book	Page



Maintenance Transaction Record

CAMP MTR ID # 2907568



This Maintenance Report is To Be Used Solely For (Check One)

Airframe Entries Eng. Serial No. PCE-VA0103 Prop. Serial No. BUA32866

Aircraft Identification and Status

A/C Serial #	A/C Unit #	A/C Registration #	Date	City ID	Total A/C Hours	Total A/C Landings	Total Engine Hrs	Total Engine Cycles	Total Prop Hrs			
208B-5098		RP-C1087	13-Feb-2018	RPLB	1995.4	3029	1995.4	3029	1995.4			

Component Changes, Inspections, Service Bulletins, or Airworthiness Directives Accomplished

Item	Transaction No.	Type	Item Name	Position	Part Number / Alternate Part	Mod Level	Part Serial	Removal Reason	Installed Part Status	TSN/TSO/TSR	Material Costs	Man Hours
5-15-08	1	2	INSPECTION DOCUMENT 08									
Comments: CARRIED OUT INSPECTION DOCUMENT 08 IAW C208B MAINTENANCE MANUAL CH 5-10-01. SATISFACTORY												

Trans Type: 1 - Component, 2 - Inspection, 3 - SB, 4 - AD, -- Misc. Removal Reasons: WO - Worn to Limits, SC - Scheduled, UN - Unscheduled, CO - Convenience, N - Other(note in comments) Installed Part Status: N - New, R - Repaired / Rebuilt, S - Serviceable, O - Overhauled, T - Tested, M - Modified, I - Inspected

Repair Facility _____	Certified Repair Station Number _____	Work Order No. 180011
Work Performed By VICTOR IAN PAULO DIONGLAY	Certificate No. 133864-AMT	Date 13-Feb-2018
I certify that the above stated maintenance and/or inspection was performed in accordance with the current regulations of the		
<input type="checkbox"/> Federal Aviation Administration <input checked="" type="checkbox"/> Other (Specify) CAAP _____ and		
THE AIRCRAFT IDENTIFIED ABOVE IS PRESENTLY AIRWORTHY AND APPROVED FOR RETURN TO SERVICE.		
Work Inspected By NESTOR DERPO	Certificate No. 119184-AMT	Date 13-Feb-2018
Pertinent details of this maintenance are on file at our facility under the above Work/Service Order Number as applicable.		

Maintenance Log	
Book	Page



Maintenance Transaction Record

CAMP MTR ID # 2915488



This Maintenance Report is To Be Used Solely For (Check One)

Airframe Entries Eng. Serial No. PCE-VA0103 Prop. Serial No. BUA32866

Aircraft Identification and Status

A/C Serial #	A/C Unit #	A/C Registration #	Date	City ID	Total A/C Hours	Total A/C Landings	Total Engine Hrs	Total Engine Cycles	Total Prop Hrs			
208B-5098		RP-C1087	13-Feb-2018	RPLB	1995.4	3029	1995.4	3029	1995.4			

Component Changes, Inspections, Service Bulletins, or Airworthiness Directives Accomplished

Item	Transaction No.	Type	Item Name	Position	Part Number / Alternate Part	Mod Level	Part Serial	Removal Reason	Installed Part Status	TSN/TSO/TSR	Material Costs	Man Hours
240301	1	1	STARTER GENERATOR		200SGL153Q-1		S00426	SC	O			

Comments: Removed part no: 200SGL153Q-1 Removed serial no: S00272.

Trans Type: 1 - Component, 2 - Inspection, 3 - SB, 4 - AD, -- Misc. Removal Reasons: WO - Worn to Limits, SC - Scheduled, UN - Unscheduled, CO - Convenience, N - Other(note in comments) Installed Part Status: N - New, R - Repaired / Rebuilt, S - Serviceable, O - Overhauled, T - Tested, M - Modified, I - Inspected

Repair Facility _____	Certified Repair Station Number _____	Work Order No. 180011
Work Performed By FREDERICK JOHN MALON	Certificate No. 110092-AMT	Date 13-Feb-2018
I certify that the above stated maintenance and/or inspection was performed in accordance with the current regulations of the		
<input type="checkbox"/> Federal Aviation Administration <input checked="" type="checkbox"/> Other (Specify) CAAP _____ and		
THE AIRCRAFT IDENTIFIED ABOVE IS PRESENTLY AIRWORTHY AND APPROVED FOR RETURN TO SERVICE.		
Work Inspected By ALLEN GABISON	Certificate No. 110205-AMT	Date 13-Feb-2018
Pertinent details of this maintenance are on file at our facility under the above Work/Service Order Number as applicable.		

Maintenance Log	
Book	Page



Maintenance Transaction Record

CAMP MTR ID # 2907578



This Maintenance Report is To Be Used Solely For (Check One)

Airframe Entries Eng. Serial No. PCE-VA0103 Prop. Serial No. BUA32866

Aircraft Identification and Status

A/C Serial #	A/C Unit #	A/C Registration #	Date	City ID	Total A/C Hours	Total A/C Landings	Total Engine Hrs	Total Engine Cycles	Total Prop Hrs			
208B-5098		RP-C1087	07-Feb-2018	RPLB	1971.6	2984	1971.6	2984	1971.6			

Component Changes, Inspections, Service Bulletins, or Airworthiness Directives Accomplished

Item	Transaction No.	Type	Item Name	Position	Part Number / Alternate Part	Mod Level	Part Serial	Removal Reason	Installed Part Status	TSN/TSO/TSR	Material Costs	Man Hours
5-15-06	1	2	INSPECTION DOCUMENT 06									
Comments: CARRIED OUT INSPECTION DOCUMENT IAW C208B MAINTENANCE MANUAL CH 5-15-06. SATISFACTORY												

Trans Type: 1 - Component, 2 - Inspection, 3 - SB, 4 - AD, -- Misc. Removal Reasons: WO - Worn to Limits, SC - Scheduled, UN - Unscheduled, CO - Convenience, N - Other(note in comments) Installed Part Status: N - New, R - Repaired / Rebuilt, S - Serviceable, O - Overhauled, T - Tested, M - Modified, I - Inspected

Repair Facility _____	Certified Repair Station Number _____	Work Order No. <u>180009</u>
Work Performed By <u>VICTOR IAN PAULO DIONGLAY</u>	Certificate No. <u>133864-AMT</u>	Date <u>07-Feb-2018</u>
I certify that the above stated maintenance and/or inspection was performed in accordance with the current regulations of the		
<input type="checkbox"/> Federal Aviation Administration <input checked="" type="checkbox"/> Other (Specify) <u>CAAP</u> and		
THE AIRCRAFT IDENTIFIED ABOVE IS PRESENTLY AIRWORTHY AND APPROVED FOR RETURN TO SERVICE.		
Work Inspected By <u>NESTOR DERPO</u>	Certificate No. <u>119184-AMT</u>	Date <u>07-Feb-2018</u>
Pertinent details of this maintenance are on file at our facility under the above Work/Service Order Number as applicable.		

Maintenance Log	
Book	Page



Maintenance Transaction Record

CAMP MTR ID # 2915099



This Maintenance Report is To Be Used Solely For (Check One)

Airframe Entries
 Eng. Serial No. PCE-VA0103
 Prop. Serial No. BUA32866

Aircraft Identification and Status

A/C Serial #	A/C Unit #	A/C Registration #	Date	City ID	Total A/C Hours	Total A/C Landings	Total Engine Hrs	Total Engine Cycles	Total Prop Hrs			
208B-5098		RP-C1087	30-Jan-2018	RPLB	1940.1	2932	1940.1	2932	1940.1			

Component Changes, Inspections, Service Bulletins, or Airworthiness Directives Accomplished

Item	Transaction No.	Type	Item Name	Position	Part Number / Alternate Part	Mod Level	Part Serial	Removal Reason	Installed Part Status	TSN/TSO/TSR	Material Costs	Man Hours
053417	1	2	UPDATE NAV DATABASE									
Comments: PERFORMED NAV DATABASE UPDATE IAW G1000 INTRIGATED FLIGHT DECK. SECTION APPENDIX B REV. A PG.584 TO 587. SATISFACTORY CYCLE: 1802												

Trans Type: 1 - Component, 2 - Inspection, 3 - SB, 4 - AD, -- Misc.
 Removal Reasons: WO - Worn to Limits, SC - Scheduled, UN - Unscheduled, CO - Convenience, N - Other(note in comments)
 Installed Part Status: N - New, R - Repaired / Rebuilt, S - Serviceable, O - Overhauled, T - Tested, M - Modified, I - Inspected

Repair Facility _____	Certified Repair Station Number _____	Work Order No. <u>180009</u>
Work Performed By <u>ARIEL JAYSON DAYRIT</u>	Certificate No. <u>102495-AMT/AMS</u>	Date <u>30-Jan-2018</u>
I certify that the above stated maintenance and/or inspection was performed in accordance with the current regulations of the <input type="checkbox"/> Federal Aviation Administration <input checked="" type="checkbox"/> Other (Specify) <u>CAAP</u> and		
THE AIRCRAFT IDENTIFIED ABOVE IS PRESENTLY AIRWORTHY AND APPROVED FOR RETURN TO SERVICE.		
Work Inspected By <u>NESTOR DERPO</u>	Certificate No. <u>119184-AMT</u>	Date <u>30-Jan-2018</u>
Pertinent details of this maintenance are on file at our facility under the above Work/Service Order Number as applicable.		

Maintenance Log	
Book	Page



Maintenance Transaction Record

CAMP MTR ID # 2915094



This Maintenance Report is To Be Used Solely For (Check One)

Airframe Entries Eng. Serial No. PCE-VA0103 Prop. Serial No. BUA32866

Aircraft Identification and Status

A/C Serial #	A/C Unit #	A/C Registration #	Date	City ID	Total A/C Hours	Total A/C Landings	Total Engine Hrs	Total Engine Cycles	Total Prop Hrs			
208B-5098		RP-C1087	02-Jan-2018	RPLB	1873.5	2813	1873.5	2813	1873.5			

Component Changes, Inspections, Service Bulletins, or Airworthiness Directives Accomplished

Item	Transaction No.	Type	Item Name	Position	Part Number / Alternate Part	Mod Level	Part Serial	Removal Reason	Installed Part Status	TSN/TSO/TSR	Material Costs	Man Hours
053417	1	2	UPDATE NAV DATABASE									
Comments: PERFORMED NAV DATABASE UPDATE IAW G1000 INTRIGATED FLIGHT DECK. SECTION APPENDIX B REV. A PG.584 TO 587. SATISFACTORY CYCLE: 1801												

Trans Type: 1 - Component, 2 - Inspection, 3 - SB, 4 - AD, -- Misc. Removal Reasons: WO - Worn to Limits, SC - Scheduled, UN - Unscheduled, CO - Convenience, N - Other(note in comments) Installed Part Status: N - New, R - Repaired / Rebuilt, S - Serviceable, O - Overhauled, T - Tested, M - Modified, I - Inspected

Repair Facility _____	Certified Repair Station Number _____	Work Order No. 180001
Work Performed By ARIEL JAYSON DAYRIT	Certificate No. 102495-AMT/AMS	Date 02-Jan-2018
I certify that the above stated maintenance and/or inspection was performed in accordance with the current regulations of the		
<input type="checkbox"/> Federal Aviation Administration <input checked="" type="checkbox"/> Other (Specify) CAAP _____ and		
THE AIRCRAFT IDENTIFIED ABOVE IS PRESENTLY AIRWORTHY AND APPROVED FOR RETURN TO SERVICE.		
Work Inspected By NESTOR DERPO	Certificate No. 119184-AMT	Date 02-Jan-2018
Pertinent details of this maintenance are on file at our facility under the above Work/Service Order Number as applicable.		

Maintenance Log	
Book	Page



Maintenance Transaction Record

CAMP MTR ID # 2907585



This Maintenance Report is To Be Used Solely For (Check One)

Airframe Entries
 Eng. Serial No. PCE-VA0103
 Prop. Serial No. BUA32866

Aircraft Identification and Status

A/C Serial #	A/C Unit #	A/C Registration #	Date	City ID	Total A/C Hours	Total A/C Landings	Total Engine Hrs	Total Engine Cycles	Total Prop Hrs			
208B-5098		RP-C1087	27-Dec-2017	RPLB	1844.8	2766	1844.8	2766	1844.8			

Component Changes, Inspections, Service Bulletins, or Airworthiness Directives Accomplished

Item	Transaction No.	Type	Item Name	Position	Part Number / Alternate Part	Mod Level	Part Serial	Removal Reason	Installed Part Status	TSN/TSO/TSR	Material Costs	Man Hours
5-15-07	1	2	INSPECTION DOCUMENT 07									
Comments: CARRIED OUT INSP IAW C208N MAINTENANCE MANUAL CH 5-15-07. SATISFACTORY												
614010	2	2	NO. 1 PROPELLER - INSPECT PROPELLER									
Comments: CARRIED OUT INSP IAW HARTZELL PROPELLER OWNER'S MANUAL 139 INSPECT AND CHECK CH 61-00-39 REV.11 DATED JULY/12 PAGE 5-7. SATISFACTORY												
790060	3	2	NO. 1 ENGINE - INSPECT AND CLEAN OIL FILTER ELEMENT FOR DEBRIS									
Comments: CARRIED OUT TASK IAW P AND WC MAINT MANUAL CH 79-20-01. SATISFACTORY												

Trans Type: 1 - Component, 2 - Inspection, 3 - SB, 4 - AD, -- Misc.
 Removal Reasons: WO - Worn to Limits, SC - Scheduled, UN - Unscheduled, CO - Convenience, N - Other(note in comments)
 Installed Part Status: N - New, R - Repaired / Rebuilt, S - Serviceable, O - Overhauled, T - Tested, M - Modified, I - Inspected

Repair Facility _____	Certified Repair Station Number _____	Work Order No. <u>170403</u>
Work Performed By <u>VICTOR IAN PAULO DIONGLAY</u>	Certificate No. <u>133864-AMT</u>	Date <u>27-Dec-2017</u>
I certify that the above stated maintenance and/or inspection was performed in accordance with the current regulations of the <input type="checkbox"/> Federal Aviation Administration <input checked="" type="checkbox"/> Other (Specify) <u>CAAP</u> and _____		
THE AIRCRAFT IDENTIFIED ABOVE IS PRESENTLY AIRWORTHY AND APPROVED FOR RETURN TO SERVICE.		
Work Inspected By <u>NESTOR DERPO</u>	Certificate No. <u>119184-AMT</u>	Date <u>27-Dec-2017</u>
Pertinent details of this maintenance are on file at our facility under the above Work/Service Order Number as applicable.		

Maintenance Log	
Book	Page



Maintenance Transaction Record

CAMP MTR ID # 2915089



This Maintenance Report is To Be Used Solely For (Check One)

Airframe Entries
 Eng. Serial No. PCE-VA0103
 Prop. Serial No. BUA32866

Aircraft Identification and Status

A/C Serial #	A/C Unit #	A/C Registration #	Date	City ID	Total A/C Hours	Total A/C Landings	Total Engine Hrs	Total Engine Cycles	Total Prop Hrs			
208B-5098		RP-C1087	05-Dec-2017	RPLB	1827	2732	1827	2732	1827			

Component Changes, Inspections, Service Bulletins, or Airworthiness Directives Accomplished

Item	Transaction No.	Type	Item Name	Position	Part Number / Alternate Part	Mod Level	Part Serial	Removal Reason	Installed Part Status	TSN/TSO/TSR	Material Costs	Man Hours
------	-----------------	------	-----------	----------	------------------------------	-----------	-------------	----------------	-----------------------	-------------	----------------	-----------

053417 1 2 UPDATE NAV DATABASE

Comments: PERFORMED NAV DATABASE UPDATE IAW G1000 INTRIGATED FLIGHT DECK. SECTION APPENDIX B REV. A PG.584 TO 587. SATISFACTORY

Trans Type: 1 - Component, 2 - Inspection, 3 - SB, 4 - AD, -- Misc. Removal Reasons: WO - Worn to Limits, SC - Scheduled, UN - Unscheduled, CO - Convenience, N - Other(note in comments) Installed Part Status: N - New, R - Repaired / Rebuilt, S - Serviceable, O - Overhauled, T - Tested, M - Modified, I - Inspected

Repair Facility _____	Certified Repair Station Number _____	Work Order No. <u>170393</u>
Work Performed By <u>ARIEL JAYSON DAYRIT</u>	Certificate No. <u>102495-AMT/AMS</u>	Date <u>05-Dec-2017</u>
I certify that the above stated maintenance and/or inspection was performed in accordance with the current regulations of the <input type="checkbox"/> Federal Aviation Administration <input checked="" type="checkbox"/> Other (Specify) <u>CAAP</u> and		
THE AIRCRAFT IDENTIFIED ABOVE IS PRESENTLY AIRWORTHY AND APPROVED FOR RETURN TO SERVICE.		
Work Inspected By <u>NESTOR DERPO</u>	Certificate No. <u>119184-AMT</u>	Date <u>05-Dec-2017</u>
Pertinent details of this maintenance are on file at our facility under the above Work/Service Order Number as applicable.		

Maintenance Log	
Book	Page



Maintenance Transaction Record

CAMP MTR ID # 2915067



This Maintenance Report is To Be Used Solely For (Check One)

Airframe Entries Eng. Serial No. PCE-VA0103 Prop. Serial No. BUA32866

Aircraft Identification and Status

A/C Serial #	A/C Unit #	A/C Registration #	Date	City ID	Total A/C Hours	Total A/C Landings	Total Engine Hrs	Total Engine Cycles	Total Prop Hrs			
208B-5098		RP-C1087	07-Nov-2017	RPLB	1799.6	2692	1799.6	2692	1799.6			

Component Changes, Inspections, Service Bulletins, or Airworthiness Directives Accomplished

Item	Transaction No.	Type	Item Name	Position	Part Number / Alternate Part	Mod Level	Part Serial	Removal Reason	Installed Part Status	TSN/TSO/TSR	Material Costs	Man Hours
053417	1	2	UPDATE NAV DATABASE									
Comments: UPDATED NAV DATABASE IAW GARMIN G1000 INTRIGATED FLIGHT DECK. SECTION APPENDIX B REV. A PG.584 TO 587. SATISFACTORY CYCLE:1711												

Trans Type: 1 - Component, 2 - Inspection, 3 - SB, 4 - AD, -- Misc. Removal Reasons: WO - Worn to Limits, SC - Scheduled, UN - Unscheduled, CO - Convenience, N - Other(note in comments) Installed Part Status: N - New, R - Repaired / Rebuilt, S - Serviceable, O - Overhauled, T - Tested, M - Modified, I - Inspected

Repair Facility _____	Certified Repair Station Number _____	Work Order No. _____
Work Performed By <u>ARIEL JAYSON DAYRIT</u>	Certificate No. <u>102495-AMT/AMS</u>	Date <u>07-Nov-2017</u>
I certify that the above stated maintenance and/or inspection was performed in accordance with the current regulations of the		
<input type="checkbox"/> Federal Aviation Administration	<input checked="" type="checkbox"/> Other (Specify) _____	CAAP _____ and _____
THE AIRCRAFT IDENTIFIED ABOVE IS PRESENTLY AIRWORTHY AND APPROVED FOR RETURN TO SERVICE.		
Work Inspected By <u>NESTOR DERPO</u>	Certificate No. <u>119184-AMT</u>	Date <u>07-Nov-2017</u>
Pertinent details of this maintenance are on file at our facility under the above Work/Service Order Number as applicable.		

Maintenance Log	
Book	Page



Maintenance Transaction Record

CAMP Systems International
8200 E. 34TH STREET
BUILDING 1600, SUITE 1607
Wichita, KS 67226
Phone: 316-462-2267/ Fax: 316-462-0791

This Maintenance Report is To Be Used Solely For (Check One)

Airframe Entries
 Eng. Serial No. PCE-VA0103
 Prop. Serial No. BUA32866

Aircraft Identification and Status

A/C Serial #	A/C Unit #	A/C Registration #	Date	City ID	Total A/C Hours	Total A/C Landings	Total Engine Hrs	Total Engine Cycles	Total Prop Hrs			
208B-5098		RP-C1087	03-Nov-2017	RPLB	1777.3	2657	1777.3	2657	1777.3			

Component Changes, Inspections, Service Bulletins, or Airworthiness Directives Accomplished

Item	Transaction No.	Type	Item Name	Position	Part Number / Alternate Part	Mod Level	Part Serial	Removal Reason	Status	Installed Part TSN/TSO/TSR	Material Costs	Man Hours
370103	1	1	VACUUM RELIEF VALVE FILTER DISCARD		C482001-0202		NSN	UN	N	0 MTH 0 HRS		
Comments: R/R VACUUM RELIEF VALVE FILTER DISCARD IAW C208B MM ATA 37-01-03. SATISFACTORY.												
5-15-06	2	2	INSPECTION DOCUMENT 06									
Comments: C/OUT INSPECTION DOCUMENT 06 IAW C208B MM ATA 5-15-06. SATISFACTORY.												

Trans Type: 1 - Component, 2 - Inspection, 3 - SB, 4 - AD, -- Misc.
 Removal Reasons: WO - Worn to Limits, SC - Scheduled, UN - Unscheduled, CO - Convenience, N - Other(note in comments)
 Installed Part Status: N - New, R - Repaired / Rebuilt, S - Serviceable, O - Overhauled, T - Tested, M - Modified, I - Inspected

Repair Facility _____	Certified Repair Station Number _____	Work Order No. <u>170368</u>	
Work Performed By <u>ARIEL JASON DAYRIT</u>	Certificate No. <u>102495-AMT</u>	Date <u>03-Nov-2017</u>	
I certify that the above stated maintenance and/or inspection was performed in accordance with the current regulations of the <input type="checkbox"/> Federal Aviation Administration <input checked="" type="checkbox"/> Other (Specify) <u>CAAP</u> and			
THE AIRCRAFT IDENTIFIED ABOVE IS PRESENTLY AIRWORTHY AND APPROVED FOR RETURN TO SERVICE.			
Work Inspected By <u>KRISTOPHER ALLEN GABISON</u>	Certificate No. <u>110205-AMT</u>	Date <u>03-Nov-2017</u>	
Pertinent details of this maintenance are on file at our facility under the above Work/Service Order Number as applicable.			

Maintenance Log	
Book	Page



Maintenance Transaction Record

CAMP MTR ID # 2907557



This Maintenance Report is To Be Used Solely For (Check One)

Airframe Entries
 Eng. Serial No. PCE-VA0103
 Prop. Serial No. BUA32866

Aircraft Identification and Status

A/C Serial #	A/C Unit #	A/C Registration #	Date	City ID	Total A/C Hours	Total A/C Landings	Total Engine Hrs	Total Engine Cycles	Total Prop Hrs			
208B-5098		RP-C1087	03-Nov-2017	RPLB	1797.3	2689	1797.3	2689	1797.3			

Component Changes, Inspections, Service Bulletins, or Airworthiness Directives Accomplished

Item	Transaction No.	Type	Item Name	Position	Part Number / Alternate Part	Mod Level	Part Serial	Removal Reason	Installed Part Status	TSN/TSO/TSR	Material Costs	Man Hours
731040	1	2	NO. 1 ENGINE - GENERAL VISUAL INSPECTION FUEL PUMP INLET SCREEN Comments: CARRIED OUT INSP GENERAL VISUAL INSP FUEL PUMP INLET SCREEN IAW P AND WC MAINTENANCE MANUAL MODEL PT6A-140 CH 05.20 SCHEDULED MAINTENANCE CHECK TASK 73-10-05-210-801 FOUND TEST AND SATISFACTORY.		3040760		012610					
750020	2	2	NO. 1 ENGINE - GENERAL VISUAL INSPECTION OF THE COMPRESSOR BLEED VALVE Comments: CARRIED OUT INSP IAW P AND WC MAINTENANCE MANUAL MODEL PT6A-140 CH 05.20 SCHEDULED MAINTENANCE CHECK TASK 75-30-01-210-801 FOUND TEST AND SATISFACTORY.		3049038-03		7819					
370102	3	1	VACUUM SYSTEM CENTRAL AIR FILTER DISCARD Comments: CARRIED OUT INSP IAW MODEL 208 REV.80 AMM REV.30 CH.37-01-02. SATISFACTORY		AAD-9-18-1		NSN	SC	N	0 MTH 0 HRS		

Trans Type: 1 - Component, 2 - Inspection, 3 - SB, 4 - AD, -- Misc.
 Removal Reasons: WO - Worn to Limits, SC - Scheduled, UN - Unscheduled, CO - Convenience, N - Other(note in comments)
 Installed Part Status: N - New, R - Repaired / Rebuilt, S - Serviceable, O - Overhauled, T - Tested, M - Modified, I - Inspected

Repair Facility _____	Certified Repair Station Number _____	Work Order No. <u>170368</u>
Work Performed By <u>ARIEL JASON DAYRIT</u>	Certificate No. <u>102495-AMT</u>	Date <u>03-Nov-2017</u>
I certify that the above stated maintenance and/or inspection was performed in accordance with the current regulations of the <input type="checkbox"/> Federal Aviation Administration <input checked="" type="checkbox"/> Other (Specify) <u>CAAP</u> and _____		
THE AIRCRAFT IDENTIFIED ABOVE IS PRESENTLY AIRWORTHY AND APPROVED FOR RETURN TO SERVICE.		
Work Inspected By <u>ALLEN GABISON</u>	Certificate No. <u>110205-AMT</u>	Date <u>03-Nov-2017</u>
Pertinent details of this maintenance are on file at our facility under the above Work/Service Order Number as applicable.		

Maintenance Log	
Book	Page



Maintenance Transaction Record

CAMP MTR ID # 2907587



This Maintenance Report is To Be Used Solely For (Check One)

Airframe Entries
 Eng. Serial No. PCE-VA0103
 Prop. Serial No. BUA32866

Aircraft Identification and Status

A/C Serial #	A/C Unit #	A/C Registration #	Date	City ID	Total A/C Hours	Total A/C Landings	Total Engine Hrs	Total Engine Cycles	Total Prop Hrs			
208B-5098		RP-C1087	03-Nov-2017	RPLB	1787.6	2671	1787.6	2671	1787.6			

Component Changes, Inspections, Service Bulletins, or Airworthiness Directives Accomplished

Item	Transaction No.	Type	Item Name	Position	Part Number / Alternate Part	Mod Level	Part Serial	Removal Reason	Installed Part Status	TSN/TSO/TSR	Material Costs	Man Hours
051260	1	2	INSPECT 25 HR INSP-FLOATS									
Comments: PERFORMED TASK IAW 8750 AMPHIBIAN/SEAPLANE FLOATS SERVICE MANUAL & ICA DOC. NO. W8750-24-01. CARRIED OUT INSP SATISFACTORILY.												
051265	2	2	INSPECT 50 HR INSP-FLOATS									
Comments: PERFORMED TASK IAW 8750 AMPHIBIAN/SEAPLANE FLOATS SERVICE MANUAL & ICA DOC. NO. W8750-24-01. CARRIED OUT INSP SATISFACTORILY.												
051270	3	2	INSPECT 100 HR INSP-FLOATS									
Comments: PERFORMED TASK IAW 8750 AMPHIBIAN/SEAPLANE FLOATS SERVICE MANUAL & ICA DOC. NO. W8750-24-01. CARRIED OUT INSP SATISFACTORILY.												
051275	4	2	INSPECT 200 HR INSP-FLOATS									
Comments: PERFORMED TASK IAW 8750 AMPHIBIAN/SEAPLANE FLOATS SERVICE MANUAL & ICA DOC. NO. W8750-24-01. CARRIED OUT INSP SATISFACTORILY.												

Trans Type: 1 - Component, 2 - Inspection, 3 - SB, 4 - AD, -- Misc.
 Removal Reasons: WO - Worn to Limits, SC - Scheduled, UN - Unscheduled, CO - Convenience, N - Other(note in comments)
 Installed Part Status: N - New, R - Repaired / Rebuilt, S - Serviceable, O - Overhauled, T - Tested, M - Modified, I - Inspected

Repair Facility _____	Certified Repair Station Number _____	Work Order No. <u>170369</u>
Work Performed By <u>VICTOR IAN PAULO DIONGLAY</u>	Certificate No. <u>133864-AMT</u>	Date <u>03-Nov-2017</u>
I certify that the above stated maintenance and/or inspection was performed in accordance with the current regulations of the <input type="checkbox"/> Federal Aviation Administration <input checked="" type="checkbox"/> Other (Specify) <u>CAAP</u> and _____		
THE AIRCRAFT IDENTIFIED ABOVE IS PRESENTLY AIRWORTHY AND APPROVED FOR RETURN TO SERVICE.		
Work Inspected By <u>NESTOR DERPO</u>	Certificate No. <u>119184-AMT</u>	Date <u>03-Nov-2017</u>
Pertinent details of this maintenance are on file at our facility under the above Work/Service Order Number as applicable.		

Maintenance Log	
Book	Page



Maintenance Transaction Record

This Maintenance Report is To Be Used Solely For (Check One)

<input checked="" type="checkbox"/> Airframe Entries	<input type="checkbox"/> Eng. Serial No. PCE-VA0103	<input type="checkbox"/> Prop. Serial No. BUA32866
--	---	--

CAMP Systems International
 8200 E. 34TH STREET
 BUILDING 1600, SUITE 1607
 Wichita, KS 67226
 Phone: 316-462-2267/ Fax: 316-462-0791

Aircraft Identification and Status

A/C Serial #	A/C Unit #	A/C Registration #	Date	City ID	Total A/C Hours	Total A/C Landings	Total Engine Hrs	Total Engine Cycles	Total Prop Hrs			
208B-5098		RP-C1087	02-Nov-2017	RPLB	1772.7	2650	1772.7	2650	1772.7			

Component Changes, Inspections, Service Bulletins, or Airworthiness Directives Accomplished

Item	Transaction No.	Type	Item Name	Position	Part Number / Alternate Part	Mod Level	Part Serial	Removal Reason	Status	Installed Part TSN/TSO/TSR	Material Costs	Man Hours
051260	1	2	INSPECT 25 HR INSP-FLOATS									
Comments: PERFORMED 25-HR FLOATS INSPECTION IAW WIPAIRE 8750 FLOATS SM (REV. C) PP. 86-89. SATISFACTORY.												

Trans Type: 1 - Component, 2 - Inspection, 3 - SB, 4 - AD, -- Misc. Removal Reasons: WO - Worn to Limits, SC - Scheduled, UN - Unscheduled, CO - Convenience, N - Other(note in comments) Installed Part Status: N - New, R - Repaired / Rebuilt, S - Serviceable, O - Overhauled, T - Tested, M - Modified, I - Inspected

Repair Facility _____	Certified Repair Station Number _____	Work Order No. S17539	
Work Performed By VICTOR IAN PAULO DIONGLAY	Certificate No. 133864-AMT	Date 02-Nov-2017	
I certify that the above stated maintenance and/or inspection was performed in accordance with the current regulations of the <input type="checkbox"/> Federal Aviation Administration <input checked="" type="checkbox"/> Other (Specify) CAAP _____ and THE AIRCRAFT IDENTIFIED ABOVE IS PRESENTLY AIRWORTHY AND APPROVED FOR RETURN TO SERVICE.			
Work Inspected By KRISTOPHER ALLEN GABISON	Certificate No. 110205-AMT	Date 02-Nov-2017	
Pertinent details of this maintenance are on file at our facility under the above Work/Service Order Number as applicable.			

Maintenance Log	
Book	Page



Maintenance Transaction Record

CAMP Systems International
8200 E. 34TH STREET
BUILDING 1600, SUITE 1607
Wichita, KS 67226
Phone: 316-462-2267/ Fax: 316-462-0791

This Maintenance Report is To Be Used Solely For (Check One)

Airframe Entries
 Eng. Serial No. PCE-VA0103
 Prop. Serial No. BUA32866

Aircraft Identification and Status

A/C Serial #	A/C Unit #	A/C Registration #	Date	City ID	Total A/C Hours	Total A/C Landings	Total Engine Hrs	Total Engine Cycles	Total Prop Hrs			
208B-5098		RP-C1087	27-Oct-2017	RPLB	1748.1	2611	1748.1	2611	1748.1			

Component Changes, Inspections, Service Bulletins, or Airworthiness Directives Accomplished

Item	Transaction No.	Type	Item Name	Position	Part Number / Alternate Part	Mod Level	Part Serial	Removal Reason	Status	Installed Part TSN/TSO/TSR	Material Costs	Man Hours
051260	1	2	INSPECT 25 HR INSP-FLOATS									
Comments: C/OUT 25-HRS FLOATS INSPECTION IAW WIPAIRE 8750 SM (REV. C) PP. 86-89. SATISFACTORY.												
051265	2	2	INSPECT 50 HR INSP-FLOATS									
Comments: C/OUT 50-HRS FLOATS INSPECTION IAW WIPAIRE 8750 SM (REV. C) PP. 86-89. SATISFACTORY.												

Trans Type: 1 - Component, 2 - Inspection, 3 - SB, 4 - AD, -- Misc.
 Removal Reasons: WO - Worn to Limits, SC - Scheduled, UN - Unscheduled, CO - Convenience, N - Other(note in comments)
 Installed Part Status: N - New, R - Repaired / Rebuilt, S - Serviceable, O - Overhauled, T - Tested, M - Modified, I - Inspected

Repair Facility _____	Certified Repair Station Number _____	Work Order No. <u>S17514</u>	
Work Performed By <u>ERIC DE LEON</u>	Certificate No. <u>110359-AMT</u>	Date <u>27-Oct-2017</u>	
I certify that the above stated maintenance and/or inspection was performed in accordance with the current regulations of the <input type="checkbox"/> Federal Aviation Administration <input checked="" type="checkbox"/> Other (Specify) <u>CAAP</u> and			
THE AIRCRAFT IDENTIFIED ABOVE IS PRESENTLY AIRWORTHY AND APPROVED FOR RETURN TO SERVICE.			
Work Inspected By <u>KRISTOPHER ALLEN GABISON</u>	Certificate No. <u>110205-AMT</u>	Date <u>27-Oct-2017</u>	
Pertinent details of this maintenance are on file at our facility under the above Work/Service Order Number as applicable.			

Maintenance Log	
Book	Page



Maintenance Transaction Record

CAMP Systems International
8200 E. 34TH STREET
BUILDING 1600, SUITE 1607
Wichita, KS 67226
Phone: 316-462-2267/ Fax: 316-462-0791

This Maintenance Report is To Be Used Solely For (Check One)

Airframe Entries
 Eng. Serial No. PCE-VA0103
 Prop. Serial No. BUA32866

Aircraft Identification and Status

A/C Serial #	A/C Unit #	A/C Registration #	Date	City ID	Total A/C Hours	Total A/C Landings	Total Engine Hrs	Total Engine Cycles	Total Prop Hrs			
208B-5098		RP-C1087	27-Oct-2017	RPLB	1748.1	2611	1748.1	2611	1748.1			

Component Changes, Inspections, Service Bulletins, or Airworthiness Directives Accomplished

Item	Transaction No.	Type	Item Name	Position	Part Number / Alternate Part	Mod Level	Part Serial	Removal Reason	Status	Installed Part TSN/TSO/TSR	Material Costs	Man Hours
2805094001	1	1	FUEL REMOTE CONTROLLER JUMPER PLUG		1006781		NSN	UN	N	0 MTH 0 HRS		

Comments: R/R JUMPER PLUG IAW WIPAIRE 8750 SM DOC. 1004433 (REV. E). SATISFACTORY.

Trans Type: 1 - Component, 2 - Inspection, 3 - SB, 4 - AD, -- Misc.
 Removal Reasons: WO - Worn to Limits, SC - Scheduled, UN - Unscheduled, CO - Convenience, N - Other(note in comments)
 Installed Part Status: N - New, R - Repaired / Rebuilt, S - Serviceable, O - Overhauled, T - Tested, M - Modified, I - Inspected

Repair Facility _____	Certified Repair Station Number _____	Work Order No. <u>S17516</u>	
Work Performed By <u>ARIEL JASON DAYRIT</u>	Certificate No. <u>102495-AMT</u>	Date <u>27-Oct-2017</u>	
I certify that the above stated maintenance and/or inspection was performed in accordance with the current regulations of the <input type="checkbox"/> Federal Aviation Administration <input checked="" type="checkbox"/> Other (Specify) <u>CAAP</u> and			
THE AIRCRAFT IDENTIFIED ABOVE IS PRESENTLY AIRWORTHY AND APPROVED FOR RETURN TO SERVICE.			
Work Inspected By <u>KRISTOPHER ALLEN GABISON</u>	Certificate No. <u>110205-AMT</u>	Date <u>27-Oct-2017</u>	
Pertinent details of this maintenance are on file at our facility under the above Work/Service Order Number as applicable.			

Maintenance Log	
Book	Page



Maintenance Transaction Record

CAMP MTR ID # 2915503



This Maintenance Report is To Be Used Solely For (Check One)

Airframe Entries Eng. Serial No. PCE-VA0103 Prop. Serial No. BUA32866

Aircraft Identification and Status

A/C Serial #	A/C Unit #	A/C Registration #	Date	City ID	Total A/C Hours	Total A/C Landings	Total Engine Hrs	Total Engine Cycles	Total Prop Hrs			
208B-5098		RP-C1087	26-Oct-2017	RPLB	1742.5	2603	1742.5	2603	1742.5			

Component Changes, Inspections, Service Bulletins, or Airworthiness Directives Accomplished

Item	Transaction No.	Type	Item Name	Position	Part Number / Alternate Part	Mod Level	Part Serial	Removal Reason	Installed Part Status	TSN/TSO/TSR	Material Costs	Man Hours
------	-----------------	------	-----------	----------	------------------------------	-----------	-------------	----------------	-----------------------	-------------	----------------	-----------

5-15-20 1 2 INSPECTION DOCUMENT 20
 Comments: CARRIED OUT IAW C208B MAINTENANCE MANUAL, TASK 25-60-00-722. SATISFACTORY

Trans Type: 1 - Component, 2 - Inspection, 3 - SB, 4 - AD, -- Misc. Removal Reasons: WO - Worn to Limits, SC - Scheduled, UN - Unscheduled, CO - Convenience, N - Other(note in comments) Installed Part Status: N - New, R - Repaired / Rebuilt, S - Serviceable, O - Overhauled, T - Tested, M - Modified, I - Inspected

Repair Facility _____	Certified Repair Station Number _____	Work Order No. 170397
Work Performed By AEROTECHNIK SERVICES, INC	Certificate No. _____	Date 26-Oct-2017
I certify that the above stated maintenance and/or inspection was performed in accordance with the current regulations of the		
<input type="checkbox"/> Federal Aviation Administration	<input checked="" type="checkbox"/> Other (Specify) _____	CAAP _____ and _____
THE AIRCRAFT IDENTIFIED ABOVE IS PRESENTLY AIRWORTHY AND APPROVED FOR RETURN TO SERVICE.		
Work Inspected By NESTOR DERPO	Certificate No. 119184-AMT	Date 26-Oct-2017
Pertinent details of this maintenance are on file at our facility under the above Work/Service Order Number as applicable.		

Maintenance Log	
Book	Page



Maintenance Transaction Record

CAMP Systems International
8200 E. 34TH STREET
BUILDING 1600, SUITE 1607
Wichita, KS 67226
Phone: 316-462-2267/ Fax: 316-462-0791

This Maintenance Report is To Be Used Solely For (Check One)

Airframe Entries
 Eng. Serial No. PCE-VA0103
 Prop. Serial No. BUA32866

Aircraft Identification and Status

A/C Serial #	A/C Unit #	A/C Registration #	Date	City ID	Total A/C Hours	Total A/C Landings	Total Engine Hrs	Total Engine Cycles	Total Prop Hrs			
208B-5098		RP-C1087	26-Oct-2017	RPLB	1742.5	2603	1742.5	2603	1742.5			

Component Changes, Inspections, Service Bulletins, or Airworthiness Directives Accomplished

Item	Transaction No.	Type	Item Name	Position	Part Number / Alternate Part	Mod Level	Part Serial	Removal Reason	Status	Installed Part TSN/TSO/TSR	Material Costs	Man Hours
FAA 2017-18-12 PARA (I) & (J)	1	4	INSPECT TO DETERMINE IF THE S/N OF THE INSTALLED PBE, P/N 119003-21, IS WITHIN THE RANGE OF 004-14768M THROUGH 004-21093M OR 004-02393M THROUGH 004-03033M AND IF FOUND WITHIN THE S/N RANGE REPLACE IT. MOC: NOT APPLICABLE Comments: NOT APPLICABLE DUE PBE NOT INSTALLED									
HC-SL-61-356	2	3	NO. 1 PROPELLER - PRIMER SEALER COLOR CHANGE, SERVICE LETTER MOC: NOT APPLICABLE Comments: NOT APPLICABLE - BLADES ARE MADE OF ALUMINUM.									

Trans Type: 1 - Component, 2 - Inspection, 3 - SB, 4 - AD, -- Misc.
 Removal Reasons: WO - Worn to Limits, SC - Scheduled, UN - Unscheduled, CO - Convenience, N - Other(note in comments)
 Installed Part Status: N - New, R - Repaired / Rebuilt, S - Serviceable, O - Overhauled, T - Tested, M - Modified, I - Inspected

Repair Facility _____	Certified Repair Station Number _____	Work Order No. <u>170355</u>	
Work Performed By <u>ERIC DE LEON</u>	Certificate No. <u>110359-AMT</u>	Date <u>26-Oct-2017</u>	
I certify that the above stated maintenance and/or inspection was performed in accordance with the current regulations of the <input type="checkbox"/> Federal Aviation Administration <input checked="" type="checkbox"/> Other (Specify) <u>CAAP</u> and			
THE AIRCRAFT IDENTIFIED ABOVE IS PRESENTLY AIRWORTHY AND APPROVED FOR RETURN TO SERVICE.			
Work Inspected By <u>KRISTOPHER ALLEN GABISON</u>	Certificate No. <u>110205-AMT</u>	Date <u>26-Oct-2017</u>	
Pertinent details of this maintenance are on file at our facility under the above Work/Service Order Number as applicable.			

Maintenance Log	
Book	Page



Maintenance Transaction Record

This Maintenance Report is To Be Used Solely For (Check One)

Airframe Entries
 Eng. Serial No. PCE-VA0103
 Prop. Serial No. BUA32866

CAMP Systems International
 8200 E. 34TH STREET
 BUILDING 1600, SUITE 1607
 Wichita, KS 67226
 Phone: 316-462-2267/ Fax: 316-462-0791

Aircraft Identification and Status

A/C Serial #	A/C Unit #	A/C Registration #	Date	City ID	Total A/C Hours	Total A/C Landings	Total Engine Hrs	Total Engine Cycles	Total Prop Hrs			
208B-5098		RP-C1087	26-Oct-2017	RPLB	1742.5	2603	1742.5	2603	1742.5			

Component Changes, Inspections, Service Bulletins, or Airworthiness Directives Accomplished

Item	Transaction No.	Type	Item Name	Position	Part Number / Alternate Part	Mod Level	Part Serial	Removal Reason	Status	Installed Part TSN/TSO/TSR	Material Costs	Man Hours
------	-----------------	------	-----------	----------	------------------------------	-----------	-------------	----------------	--------	----------------------------	----------------	-----------

5-15-20 1 2 INSPECTION DOCUMENT 20

Comments: C/OUT INSPECTION DOCUMENT 20 IAW C208B MM PER 5-15-20 TASK BY AVIATION SUPPORT INTERNATIONAL, INC. SATISFACTORY.

Trans Type: 1 - Component, 2 - Inspection, 3 - SB, 4 - AD, -- Misc. Removal Reasons: WO - Worn to Limits, SC - Scheduled, UN - Unscheduled, CO - Convenience, N - Other(note in comments) Installed Part Status: N - New, R - Repaired / Rebuilt, S - Serviceable, O - Overhauled, T - Tested, M - Modified, I - Inspected

Repair Facility _____	Certified Repair Station Number _____	Work Order No. <u>170357</u>	
Work Performed By <u>AVIATION SUPPORT INTERNATIONAL INC.</u>	Certificate No. _____	Date <u>26-Oct-2017</u>	
I certify that the above stated maintenance and/or inspection was performed in accordance with the current regulations of the <input type="checkbox"/> Federal Aviation Administration <input checked="" type="checkbox"/> Other (Specify) <u>CAAP</u> and			
THE AIRCRAFT IDENTIFIED ABOVE IS PRESENTLY AIRWORTHY AND APPROVED FOR RETURN TO SERVICE.			
Work Inspected By <u>KRISTOPHER ALLEN GABISON</u>	Certificate No. <u>110205-AMT</u>	Date <u>26-Oct-2017</u>	
Pertinent details of this maintenance are on file at our facility under the above Work/Service Order Number as applicable.			

Maintenance Log	
Book	Page



Maintenance Transaction Record

CAMP Systems International
8200 E. 34TH STREET
BUILDING 1600, SUITE 1607
Wichita, KS 67226
Phone: 316-462-2267/ Fax: 316-462-0791

This Maintenance Report is To Be Used Solely For (Check One)

Airframe Entries
 Eng. Serial No.
 Prop. Serial No.

Aircraft Identification and Status

A/C Serial #	A/C Unit #	A/C Registration #	Date	City ID	Total A/C Hours	Total A/C Landings	Total Engine Hrs	Total Engine Cycles	Total Prop Hrs			
208B-5098		RP-C1087	22-Oct-2017	RPLB	1722.9	2568	1722.9	2568	1722.9			

Component Changes, Inspections, Service Bulletins, or Airworthiness Directives Accomplished

Item	Transaction No.	Type	Item Name	Position	Part Number / Alternate Part	Mod Level	Part Serial	Removal Reason	Status	Installed Part TSN/TSO/TSR	Material Costs	Man Hours
------	-----------------	------	-----------	----------	------------------------------	-----------	-------------	----------------	--------	----------------------------	----------------	-----------

051260 1 2 INSPECT 25 HR INSP-FLOATS

Comments:

Trans Type: 1 - Component, 2 - Inspection, 3 - SB, 4 - AD, -- Misc.
 Removal Reasons: WO - Worn to Limits, SC - Scheduled, UN - Unscheduled, CO - Convenience, N - Other(note in comments)
 Installed Part Status: N - New, R - Repaired / Rebuilt, S - Serviceable, O - Overhauled, T - Tested, M - Modified, I - Inspected

Repair Facility	SUBIC	Certified Repair Station Number		Work Order No.	S17502
Work Performed By	JASON DAYRIT	Certificate No.	102495	Date	22-Oct-2017
I certify that the above stated maintenance and/or inspection was performed in accordance with the current regulations of the <input type="checkbox"/> Federal Aviation Administration <input checked="" type="checkbox"/> Other (Specify) CAAP _____ and _____					
THE AIRCRAFT IDENTIFIED ABOVE IS PRESENTLY AIRWORTHY AND APPROVED FOR RETURN TO SERVICE.					
Work Inspected By	ALLEN GABISON	Certificate No.	110205	Date	22-Oct-2017
Pertinent details of this maintenance are on file at our facility under the above Work/Service Order Number as applicable.					

Maintenance Log	
Book	Page



Maintenance Transaction Record

CAMP Systems International
8200 E. 34TH STREET
BUILDING 1600, SUITE 1607
Wichita, KS 67226
Phone: 316-462-2267/ Fax: 316-462-0791

This Maintenance Report is To Be Used Solely For (Check One)

Airframe Entries
 Eng. Serial No. PCE-VA0103
 Prop. Serial No. BUA32866

Aircraft Identification and Status

A/C Serial #	A/C Unit #	A/C Registration #	Date	City ID	Total A/C Hours	Total A/C Landings	Total Engine Hrs	Total Engine Cycles	Total Prop Hrs			
208B-5098		RP-C1087	22-Oct-2017	RPLB	1722.9	2568	1722.9	2568	1722.9			

Component Changes, Inspections, Service Bulletins, or Airworthiness Directives Accomplished

Item	Transaction No.	Type	Item Name	Position	Part Number / Alternate Part	Mod Level	Part Serial	Removal Reason	Status	Installed Part TSN/TSO/TSR	Material Costs	Man Hours
051260	1	2	INSPECT 25 HR INSP-FLOATS									
Comments: C/OUT 25-HRS FLOATS INSPECTION IAW WIPAIRE 8750 MM (REV. C) PP. 86-89. SATISFACTORY.												

Trans Type: 1 - Component, 2 - Inspection, 3 - SB, 4 - AD, -- Misc.
 Removal Reasons: WO - Worn to Limits, SC - Scheduled, UN - Unscheduled, CO - Convenience, N - Other(note in comments)
 Installed Part Status: N - New, R - Repaired / Rebuilt, S - Serviceable, O - Overhauled, T - Tested, M - Modified, I - Inspected

Repair Facility _____	Certified Repair Station Number _____	Work Order No. <u>S17502</u>	
Work Performed By <u>ERIC DE LEON</u>	Certificate No. <u>110359-AMT</u>	Date <u>22-Oct-2017</u>	
I certify that the above stated maintenance and/or inspection was performed in accordance with the current regulations of the <input type="checkbox"/> Federal Aviation Administration <input checked="" type="checkbox"/> Other (Specify) <u>CAAP</u> and			
THE AIRCRAFT IDENTIFIED ABOVE IS PRESENTLY AIRWORTHY AND APPROVED FOR RETURN TO SERVICE.			
Work Inspected By <u>KRISTOPHER ALLEN GABISON</u>	Certificate No. <u>110205-AMT</u>	Date <u>22-Oct-2017</u>	
Pertinent details of this maintenance are on file at our facility under the above Work/Service Order Number as applicable.			

Maintenance Log	
Book	Page



Maintenance Transaction Record

CAMP Systems International
8200 E. 34TH STREET
BUILDING 1600, SUITE 1607
Wichita, KS 67226
Phone: 316-462-2267/ Fax: 316-462-0791

This Maintenance Report is To Be Used Solely For (Check One)

Airframe Entries
 Eng. Serial No.
 Prop. Serial No.

Aircraft Identification and Status

A/C Serial #	A/C Unit #	A/C Registration #	Date	City ID	Total A/C Hours	Total A/C Landings	Total Engine Hrs	Total Engine Cycles	Total Prop Hrs			
208B-5098		RP-C1087	12-Oct-2017	RPLB	1695.8	2524	1695.8	2524	1695.8			

Component Changes, Inspections, Service Bulletins, or Airworthiness Directives Accomplished

Item	Transaction No.	Type	Item Name	Position	Part Number / Alternate Part	Mod Level	Part Serial	Removal Reason	Status	Installed Part TSN/TSO/TSR	Material Costs	Man Hours
051270	1	2	INSPECT 100 HR INSP-FLOATS									
Comments:												
057010	2	2	NO. 1 ENGINE - MINOR INSPECTION									
Comments:												

Trans Type: 1 - Component, 2 - Inspection, 3 - SB, 4 - AD, -- Misc.
 Removal Reasons: WO - Worn to Limits, SC - Scheduled, UN - Unscheduled, CO - Convenience, N - Other(note in comments)
 Installed Part Status: N - New, R - Repaired / Rebuilt, S - Serviceable, O - Overhauled, T - Tested, M - Modified, I - Inspected

Repair Facility	SUBIC	Certified Repair Station Number	Work Order No.	S17491
Work Performed By	ERIC DE LEON	Certificate No.	110359	Date
I certify that the above stated maintenance and/or inspection was performed in accordance with the current regulations of the <input type="checkbox"/> Federal Aviation Administration <input checked="" type="checkbox"/> Other (Specify) CAAP and				
THE AIRCRAFT IDENTIFIED ABOVE IS PRESENTLY AIRWORTHY AND APPROVED FOR RETURN TO SERVICE.				
Work Inspected By	ARISTEO ALCALA	Certificate No.	115162	Date
Pertinent details of this maintenance are on file at our facility under the above Work/Service Order Number as applicable.				

Maintenance Log	
Book	Page



Maintenance Transaction Record

CAMP Systems International
8200 E. 34TH STREET
BUILDING 1600, SUITE 1607
Wichita, KS 67226
Phone: 316-462-2267/ Fax: 316-462-0791

This Maintenance Report is To Be Used Solely For (Check One)

Airframe Entries
 Eng. Serial No. PCE-VA0103
 Prop. Serial No. BUA32866

Aircraft Identification and Status

A/C Serial #	A/C Unit #	A/C Registration #	Date	City ID	Total A/C Hours	Total A/C Landings	Total Engine Hrs	Total Engine Cycles	Total Prop Hrs			
208B-5098		RP-C1087	12-Oct-2017	RPLB	1695.8	2524	1695.8	2524	1695.8			

Component Changes, Inspections, Service Bulletins, or Airworthiness Directives Accomplished

Item	Transaction No.	Type	Item Name	Position	Part Number / Alternate Part	Mod Level	Part Serial	Removal Reason	Status	Installed Part TSN/TSO/TSR	Material Costs	Man Hours
051265	1	2	INSPECT 50 HR INSP-FLOATS									
Comments: C/OUT 50-HRS FLOATS INSPECTION IAW WIPAIRE 8750 MM (REV. C) PP. 86-89. SATISFACTORY.												

Trans Type: 1 - Component, 2 - Inspection, 3 - SB, 4 - AD, -- Misc.
 Removal Reasons: WO - Worn to Limits, SC - Scheduled, UN - Unscheduled, CO - Convenience, N - Other(note in comments)
 Installed Part Status: N - New, R - Repaired / Rebuilt, S - Serviceable, O - Overhauled, T - Tested, M - Modified, I - Inspected

Repair Facility _____	Certified Repair Station Number _____	Work Order No. <u>S17491</u>	
Work Performed By <u>ERIC DE LEON</u>	Certificate No. <u>110359-AMT</u>	Date <u>12-Oct-2017</u>	
I certify that the above stated maintenance and/or inspection was performed in accordance with the current regulations of the <input type="checkbox"/> Federal Aviation Administration <input checked="" type="checkbox"/> Other (Specify) <u>CAAP</u> and			
THE AIRCRAFT IDENTIFIED ABOVE IS PRESENTLY AIRWORTHY AND APPROVED FOR RETURN TO SERVICE.			
Work Inspected By <u>ARISTEO ALCALA</u>	Certificate No. <u>115162-AMT</u>	Date <u>12-Oct-2017</u>	
Pertinent details of this maintenance are on file at our facility under the above Work/Service Order Number as applicable.			

Maintenance Log	
Book	Page



Maintenance Transaction Record

CAMP Systems International
8200 E. 34TH STREET
BUILDING 1600, SUITE 1607
Wichita, KS 67226
Phone: 316-462-2267/ Fax: 316-462-0791

This Maintenance Report is To Be Used Solely For (Check One)

Airframe Entries
 Eng. Serial No. PCE-VA0103
 Prop. Serial No. BUA32866

Aircraft Identification and Status

A/C Serial #	A/C Unit #	A/C Registration #	Date	City ID	Total A/C Hours	Total A/C Landings	Total Engine Hrs	Total Engine Cycles	Total Prop Hrs			
208B-5098		RP-C1087	12-Oct-2017	RPLB	1695.8	2524	1695.8	2524	1695.8			

Component Changes, Inspections, Service Bulletins, or Airworthiness Directives Accomplished

Item	Transaction No.	Type	Item Name	Position	Part Number / Alternate Part	Mod Level	Part Serial	Removal Reason	Status	Installed Part TSN/TSO/TSR	Material Costs	Man Hours
051260	1	2	INSPECT 25 HR INSP-FLOATS									
Comments: C/OUT 25-HRS FLOATS INSPECTION IAW WIPAIRE 8750 MM (REV. C) PP. 86-89. SATISFACTORY.												

Trans Type: 1 - Component, 2 - Inspection, 3 - SB, 4 - AD, -- Misc.
 Removal Reasons: WO - Worn to Limits, SC - Scheduled, UN - Unscheduled, CO - Convenience, N - Other(note in comments)
 Installed Part Status: N - New, R - Repaired / Rebuilt, S - Serviceable, O - Overhauled, T - Tested, M - Modified, I - Inspected

Repair Facility _____	Certified Repair Station Number _____	Work Order No. <u>S17491</u>	
Work Performed By <u>ERIC DE LEON</u>	Certificate No. <u>110359-AMT</u>	Date <u>12-Oct-2017</u>	
I certify that the above stated maintenance and/or inspection was performed in accordance with the current regulations of the			
<input type="checkbox"/> Federal Aviation Administration <input checked="" type="checkbox"/> Other (Specify) <u>CAAP</u> and			
THE AIRCRAFT IDENTIFIED ABOVE IS PRESENTLY AIRWORTHY AND APPROVED FOR RETURN TO SERVICE.			
Work Inspected By <u>ARISTEO ALCALA</u>	Certificate No. <u>115162-AMT</u>	Date <u>12-Oct-2017</u>	
Pertinent details of this maintenance are on file at our facility under the above Work/Service Order Number as applicable.			

Maintenance Log	
Book	Page



Maintenance Transaction Record

CAMP Systems International
8200 E. 34TH STREET
BUILDING 1600, SUITE 1607
Wichita, KS 67226
Phone: 316-462-2267/ Fax: 316-462-0791

This Maintenance Report is To Be Used Solely For (Check One)

Airframe Entries
 Eng. Serial No. PCE-VA0103
 Prop. Serial No. BUA32866

Aircraft Identification and Status

A/C Serial #	A/C Unit #	A/C Registration #	Date	City ID	Total A/C Hours	Total A/C Landings	Total Engine Hrs	Total Engine Cycles	Total Prop Hrs			
208B-5098		RP-C1087	12-Oct-2017	RPLB	1695.8	2514	1695.8	2514	1695.8			

Component Changes, Inspections, Service Bulletins, or Airworthiness Directives Accomplished

Item	Transaction No.	Type	Item Name	Position	Part Number / Alternate Part	Mod Level	Part Serial	Removal Reason	Status	Installed Part TSN/TSO/TSR	Material Costs	Man Hours
------	-----------------	------	-----------	----------	------------------------------	-----------	-------------	----------------	--------	----------------------------	----------------	-----------

053417 1 2 UPDATE NAV DATABASE
 Comments: C/OUT NAV DATABASE UPDATE IAW GARMIN G1000 MM PER 053417 TASK. SATISFACTORY.

Trans Type: 1 - Component, 2 - Inspection, 3 - SB, 4 - AD, -- Misc. Removal Reasons: WO - Worn to Limits, SC - Scheduled, UN - Unscheduled, CO - Convenience, N - Other(note in comments) Installed Part Status: N - New, R - Repaired / Rebuilt, S - Serviceable, O - Overhauled, T - Tested, M - Modified, I - Inspected

Repair Facility _____	Certified Repair Station Number _____	Work Order No. <u>S17522</u>	
Work Performed By <u>ARIEL JASON DAYRIT</u>	Certificate No. <u>102495-AMT</u>	Date <u>12-Oct-2017</u>	
I certify that the above stated maintenance and/or inspection was performed in accordance with the current regulations of the <input type="checkbox"/> Federal Aviation Administration <input checked="" type="checkbox"/> Other (Specify) <u>CAAP</u> and			
THE AIRCRAFT IDENTIFIED ABOVE IS PRESENTLY AIRWORTHY AND APPROVED FOR RETURN TO SERVICE.			
Work Inspected By <u>ROMEIO LERIOS II</u>	Certificate No. <u>112167-AMT/AMS</u>	Date <u>12-Oct-2017</u>	
Pertinent details of this maintenance are on file at our facility under the above Work/Service Order Number as applicable.			

Maintenance Log	
Book	Page



Maintenance Transaction Record

This Maintenance Report is To Be Used Solely For (Check One)

Airframe Entries
 Eng. Serial No. PCE-VA0103
 Prop. Serial No. BUA32866

CAMP Systems International
 8200 E. 34TH STREET
 BUILDING 1600, SUITE 1607
 Wichita, KS 67226
 Phone: 316-462-2267/ Fax: 316-462-0791

Aircraft Identification and Status

A/C Serial #	A/C Unit #	A/C Registration #	Date	City ID	Total A/C Hours	Total A/C Landings	Total Engine Hrs	Total Engine Cycles	Total Prop Hrs			
208B-5098		RP-C1087	12-Oct-2017	RPLB	1695.8	2524	1695.8	2524	1695.8			

Component Changes, Inspections, Service Bulletins, or Airworthiness Directives Accomplished

Item	Transaction No.	Type	Item Name	Position	Part Number / Alternate Part	Mod Level	Part Serial	Removal Reason	Status	Installed Part TSN/TSO/TSR	Material Costs	Man Hours
051270	1	2	INSPECT 100 HR INSP-FLOATS									
Comments: C/OUT 100-HRS FLOATS INSPECTION IAW WIPAIRE 8750 SM (REV. C) PP/ 86-89. SATISFACTORY.												

Trans Type: 1 - Component, 2 - Inspection, 3 - SB, 4 - AD, -- Misc.
 Removal Reasons: WO - Worn to Limits, SC - Scheduled, UN - Unscheduled, CO - Convenience, N - Other(note in comments)
 Installed Part Status: N - New, R - Repaired / Rebuilt, S - Serviceable, O - Overhauled, T - Tested, M - Modified, I - Inspected

Repair Facility _____	Certified Repair Station Number _____	Work Order No. <u>S17491</u>	
Work Performed By <u>ERIC DE LEON</u>	Certificate No. <u>110359-AMT</u>	Date <u>12-Oct-2017</u>	
I certify that the above stated maintenance and/or inspection was performed in accordance with the current regulations of the <input type="checkbox"/> Federal Aviation Administration <input checked="" type="checkbox"/> Other (Specify) <u>CAAP</u> and			
THE AIRCRAFT IDENTIFIED ABOVE IS PRESENTLY AIRWORTHY AND APPROVED FOR RETURN TO SERVICE.			
Work Inspected By <u>ARISTEO ALCALA</u>	Certificate No. <u>115162-AMT</u>	Date <u>12-Oct-2017</u>	
Pertinent details of this maintenance are on file at our facility under the above Work/Service Order Number as applicable.			

Maintenance Log	
Book	Page



Maintenance Transaction Record

CAMP Systems International
8200 E. 34TH STREET
BUILDING 1600, SUITE 1607
Wichita, KS 67226
Phone: 316-462-2267/ Fax: 316-462-0791

This Maintenance Report is To Be Used Solely For (Check One)

Airframe Entries
 Eng. Serial No. PCE-VA0103
 Prop. Serial No. BUA32866

Aircraft Identification and Status

A/C Serial #	A/C Unit #	A/C Registration #	Date	City ID	Total A/C Hours	Total A/C Landings	Total Engine Hrs	Total Engine Cycles	Total Prop Hrs			
208B-5098		RP-C1087	05-Oct-2017	RPLB	1672.4	2481	1672.4	2481	1672.4			

Component Changes, Inspections, Service Bulletins, or Airworthiness Directives Accomplished

Item	Transaction No.	Type	Item Name	Position	Part Number / Alternate Part	Mod Level	Part Serial	Removal Reason	Status	Installed Part TSN/TSO/TSR	Material Costs	Man Hours
051260	1	2	INSPECT 25 HR INSP-FLOATS									
Comments: C/OUT 25-HRS FLOATS INSPECTION IAW WIPAIRE 8750 MM (REV. C) PP. 86-89. SATISFACTORY.												

Trans Type: 1 - Component, 2 - Inspection, 3 - SB, 4 - AD, -- Misc.
 Removal Reasons: WO - Worn to Limits, SC - Scheduled, UN - Unscheduled, CO - Convenience, N - Other(note in comments)
 Installed Part Status: N - New, R - Repaired / Rebuilt, S - Serviceable, O - Overhauled, T - Tested, M - Modified, I - Inspected

Repair Facility _____	Certified Repair Station Number _____	Work Order No. <u>S17481</u>	
Work Performed By <u>ERIC DE LEON</u>	Certificate No. <u>110359-AMT</u>	Date <u>05-Oct-2017</u>	
I certify that the above stated maintenance and/or inspection was performed in accordance with the current regulations of the <input type="checkbox"/> Federal Aviation Administration <input checked="" type="checkbox"/> Other (Specify) <u>CAAP</u> and			
THE AIRCRAFT IDENTIFIED ABOVE IS PRESENTLY AIRWORTHY AND APPROVED FOR RETURN TO SERVICE.			
Work Inspected By <u>KRISTOPHER ALLEN GABISON</u>	Certificate No. <u>110205-AMT</u>	Date <u>05-Oct-2017</u>	
Pertinent details of this maintenance are on file at our facility under the above Work/Service Order Number as applicable.			

Maintenance Log	
Book	Page



Maintenance Transaction Record



This Maintenance Report is To Be Used Solely For (Check One)

Airframe Entries Eng. Serial No. PCE-VA0103 Prop. Serial No. BUA32866

CAMP Systems International
8200 E. 34TH STREET
BUILDING 1600, SUITE 1607
Wichita, KS 67226
Phone: 316-462-2267/ Fax: 316-462-0791

Aircraft Identification and Status

Table with columns: A/C Serial #, A/C Unit #, A/C Registration #, Date, City ID, Total A/C Hours, Total A/C Landings, Total Engine Hrs, Total Engine Cycles, Total Prop Hrs. Row 1: 208B-5098, RP-C1087, 27-Sep-2017, RPLB, 1648.3, 2450, 1648.3, 2450, 1648.3

Component Changes, Inspections, Service Bulletins, or Airworthiness Directives Accomplished

Table with columns: Item, Transaction No. Type, Item Name, Position, Part Number / Alternate Part Number, Mod Level, Part Serial, Removal Reason, Installed Part Status TSN/TSO/TSR, Material Costs, Man Hours. Row 1: 2776059001, 1 1, TORQUE PRESSURE TRANSDUCER, 3049260-3, 14060363, UN, N, 0 MTH 0 HRS. Comments: R/R TORQUE PRESSURE TRANSDUCER IAW PT6A-140 MM ATA 71-10-01. GROUND RUN CHECK SATISFACTORY.

Trans. Type: 1 - Component, 2 - Inspection, 3 - SB, 4 - AD, - - Misc.

Removal Reasons: WO - Worn to Limits, SC - Scheduled, UN - Unscheduled, CO - Convenience, N - Other(note in comments)

Installed Part Status: N - New, R - Repaired/Rebuilt, S - Serviceable, O - Overhauled

Repair Facility, Certified Repair Station Number, Work Order No. S17464, Date 27-Sep-2017. Work Performed By VICTOR IAN PAOLO DIONGLAY, Certificate No. 133864-AMT. I certify that the above stated maintenance and/or inspection was performed in accordance with the current regulations of the Federal Aviation Administration and Other (Specify) CAAP. THE AIRCRAFT IDENTIFIED ABOVE IS PRESENTLY AIRWORTHY AND APPROVED FOR RETURN TO SERVICE. Work Inspected By KRISTOPHER ALLEN GABISON, Certificate No. 110205-AMT, Date 27-Sep-2017. Pertinent details of this maintenance are on file at our facility under the above Work/Service Order Number as applicable.

Maintenance Log table with columns: Book, Page



Maintenance Transaction Record



This Maintenance Report is To Be Used Solely For (Check One)

Form with checkboxes for Airframe Entries, Eng. Serial No. (PCE-VA0103), and Prop. Serial No. (BUA32866)

CAMP Systems International
8200 E. 34TH STREET
BUILDING 1600, SUITE 1607
Wichita, KS 67226
Phone: 316-462-2267/ Fax: 316-462-0791

Aircraft Identification and Status

Table with columns: A/C Serial #, A/C Unit #, A/C Registration #, Date, City ID, Total A/C Hours, Total A/C Landings, Total Engine Hrs, Total Engine Cycles, Total Prop Hrs

Component Changes, Inspections, Service Bulletins, or Airworthiness Directives Accomplished

Table with columns: Item, Transaction No. Type, Item Name, Position, Part Number / Alternate Part Number, Mod Level, Part Serial, Removal Reason, Installed Part Status TSN/TSO/TSR, Material Costs, Man Hours

Trans. Type: 1 - Component, 2 - Inspection, 3 - SB, 4 - AD, - - Misc.

Removal Reasons: WO - Worn to Limits, SC - Scheduled, UN - Unscheduled, CO - Convenience, N - Other(note in comments)

Installed Part Status: N - New, R - Repaired/Rebuilt, S - Serviceable, O - Overhauled

Main repair record form containing fields for Repair Facility, Certified Repair Station Number, Work Order No., Work Performed By, Date, and Work Inspected By.

Maintenance Log table with columns: Book, Page



Maintenance Transaction Record



This Maintenance Report is To Be Used Solely For (Check One)

Airframe Entries Eng. Serial No. PCE-VA0103 Prop. Serial No. BUA32866

CAMP Systems International
8200 E. 34TH STREET
BUILDING 1600, SUITE 1607
Wichita, KS 67226
Phone: 316-462-2267/ Fax: 316-462-0791

Aircraft Identification and Status

Table with columns: A/C Serial #, A/C Unit #, A/C Registration #, Date, City ID, Total A/C Hours, Total A/C Landings, Total Engine Hrs, Total Engine Cycles, Total Prop Hrs. Row 1: 208B-5098, RP-C1087, 16-Sep-2017, RPLB, 1622.3, 2410, 1622.3, 2410, 1622.3

Component Changes, Inspections, Service Bulletins, or Airworthiness Directives Accomplished

Table with columns: Item, Transaction No. Type, Item Name, Position, Part Number / Alternate Part Number, Mod Level, Part Serial, Removal Reason, Installed Part Status TSN/TSO/TSR, Material Costs, Man Hours. Row 1: 051260, 1 2, INSPECT 25 HR INSP-FLOATS, Comments: PERFORMED 25 HR FLOATS INSPECTION IAW WIPAIRE 8750 FLOATS SERVICE MANUAL PP. 86-89. SATISFACTORY

Trans. Type: 1 - Component, 2 - Inspection, 3 - SB, 4 - AD, - - Misc.

Removal Reasons: WO - Worn to Limits, SC - Scheduled, UN - Unscheduled, CO - Convenience, N - Other(note in comments)

Installed Part Status: N - New, R - Repaired/Rebuilt, S - Serviceable, O - Overhauled

Repair Facility, Certified Repair Station Number, Work Order No. S17436, Work Performed By ERIC DE LEON, Certificate No. 110359-AMT, Date 16-Sep-2017. I certify that the above stated maintenance and/or inspection was performed in accordance with the current regulations of the Federal Aviation Administration and Other (Specify) CAAP. THE AIRCRAFT IDENTIFIED ABOVE IS PRESENTLY AIRWORTHY AND APPROVED FOR RETURN TO SERVICE. Work Inspected By JAYSON RAMOS, Certificate No. 110593-AMT, Date 16-Sep-2017. Pertinent details of this maintenance are on file at our facility under the above Work/Service Order Number as applicable.

Maintenance Log table with columns: Book, Page



Maintenance Transaction Record



This Maintenance Report is To Be Used Solely For (Check One)

Airframe Entries Eng. Serial No. PCE-VA0103 Prop. Serial No. BUA32866

CAMP Systems International
8200 E. 34TH STREET
BUILDING 1600, SUITE 1607
Wichita, KS 67226
Phone: 316-462-2267/ Fax: 316-462-0791

Aircraft Identification and Status

Table with columns: A/C Serial #, A/C Unit #, A/C Registration #, Date, City ID, Total A/C Hours, Total A/C Landings, Total Engine Hrs, Total Engine Cycles, Total Prop Hrs. Row 1: 208B-5098, RP-C1087, 13-Sep-2017, RPLB, 1613.4, 2395, 1613.4, 2395, 1613.4

Component Changes, Inspections, Service Bulletins, or Airworthiness Directives Accomplished

Table with columns: Item, Transaction No. Type, Item Name, Position, Part Number / Alternate Part Number, Mod Level, Part Serial, Removal Reason, Installed Part Status TSN/TSO/TSR, Material Costs, Man Hours. Row 1: 051001, 1 2, RENEWAL AIRWORTHINESS, Comments: C/OUT RENEWAL AIRWORTHINESS. SATISFACTORY.

Trans. Type: 1 - Component, 2 - Inspection, 3 - SB, 4 - AD, - - Misc.

Removal Reasons: WO - Worn to Limits, SC - Scheduled, UN - Unscheduled, CO - Convenience, N - Other(note in comments)

Installed Part Status: N - New, R - Repaired/Rebuilt, S - Serviceable, O - Overhauled

Repair Facility, Certified Repair Station Number, Work Order No. S17431, Work Performed By ERIC DE LEON, Certificate No. 110359-AMT, Date 13-Sep-2017. I certify that the above stated maintenance and/or inspection was performed in accordance with the current regulations of the Federal Aviation Administration and Other (Specify) CAAP. THE AIRCRAFT IDENTIFIED ABOVE IS PRESENTLY AIRWORTHY AND APPROVED FOR RETURN TO SERVICE. Work Inspected By ARISTEO ALCALA, Certificate No. 115162-AMT, Date 13-Sep-2017. Pertinent details of this maintenance are on file at our facility under the above Work/Service Order Number as applicable.

Maintenance Log table with columns: Book, Page



Maintenance Transaction Record



This Maintenance Report is To Be Used Solely For (Check One)

Airframe Entries Eng. Serial No. PCE-VA0103 Prop. Serial No. BUA32866

CAMP Systems International
8200 E. 34TH STREET
BUILDING 1600, SUITE 1607
Wichita, KS 67226
Phone: 316-462-2267/ Fax: 316-462-0791

Aircraft Identification and Status

Table with columns: A/C Serial #, A/C Unit #, A/C Registration #, Date, City ID, Total A/C Hours, Total A/C Landings, Total Engine Hrs, Total Engine Cycles, Total Prop Hrs. Row 1: 208B-5098, RP-C1087, 07-Sep-2017, RPLB, 1605.6, 2380, 1605.6, 2380, 1605.6

Component Changes, Inspections, Service Bulletins, or Airworthiness Directives Accomplished

Table with columns: Item, Transaction No. Type, Item Name, Position, Part Number / Alternate Part Number, Mod Level, Part Serial, Removal Reason, Installed Part Status TSN/TSO/TSR, Material Costs, Man Hours. Row 1: 053417, 1 2, UPDATE NAV DATABASE, Comments: UPDATED NAV DATABASE IAW GARMIN G1000 COCKPIT REFERENCE GUIDE FOR THE CESSNA NAV III SEC. 1.8 REV. A. SATISFACTORY. CYCLE: 1710 NEXT DUE: 12 OCT 2017

Trans. Type: 1 - Component, 2 - Inspection, 3 - SB, 4 - AD, - - Misc.

Removal Reasons: WO - Worn to Limits, SC - Scheduled, UN - Unscheduled, CO - Convenience, N - Other(note in comments)

Installed Part Status: N - New, R - Repaired/Rebuilt, S - Serviceable, O - Overhauled

Repair Facility, Certified Repair Station Number, Work Order No. S17421, Date 07-Sep-2017. I certify that the above stated maintenance and/or inspection was performed in accordance with the current regulations of the Federal Aviation Administration and CAAP. THE AIRCRAFT IDENTIFIED ABOVE IS PRESENTLY AIRWORTHY AND APPROVED FOR RETURN TO SERVICE.

Maintenance Log table with columns: Book, Page



Maintenance Transaction Record



This Maintenance Report is To Be Used Solely For (Check One)

Airframe Entries Eng. Serial No. PCE-VA0103 Prop. Serial No. BUA32866

CAMP Systems International
8200 E. 34TH STREET
BUILDING 1600, SUITE 1607
Wichita, KS 67226
Phone: 316-462-2267/ Fax: 316-462-0791

Aircraft Identification and Status

Table with columns: A/C Serial #, A/C Unit #, A/C Registration #, Date, City ID, Total A/C Hours, Total A/C Landings, Total Engine Hrs, Total Engine Cycles, Total Prop Hrs. Row 1: 208B-5098, RP-C1087, 03-Sep-2017, RPLB, 1597.5, 2361, 1597.5, 2361, 1597.5

Component Changes, Inspections, Service Bulletins, or Airworthiness Directives Accomplished

Table with columns: Item, Transaction No. Type, Item Name, Position, Part Number / Alternate Part Number, Mod Level, Part Serial, Removal Reason, Installed Part Status TSN/TSO/TSR, Material Costs, Man Hours. Rows include inspection items 051260, 051265, and 051275 with comments.

Trans. Type: 1 - Component, 2 - Inspection, 3 - SB, 4 - AD, - - Misc.

Removal Reasons: WO - Worn to Limits, SC - Scheduled, UN - Unscheduled, CO - Convenience, N - Other(note in comments)

Installed Part Status: N - New, R - Repaired/Rebuilt, S - Serviceable, O - Overhauled

Repair Facility, Certified Repair Station Number, Work Order No. S17411, Work Performed By ERIC DE LEON, Certificate No. 110359-AMT, Date 03-Sep-2017. Includes certification text and Work Inspected By JAYSON RAMOS, Certificate No. 110593-AMT, Date 03-Sep-2017.

Maintenance Log table with columns: Book, Page



Maintenance Transaction Record



This Maintenance Report is To Be Used Solely For (Check One)

Form with checkboxes for Airframe Entries, Eng. Serial No. (PCE-VA0103), and Prop. Serial No. (BUA32866)

CAMP Systems International
8200 E. 34TH STREET
BUILDING 1600, SUITE 1607
Wichita, KS 67226
Phone: 316-462-2267/ Fax: 316-462-0791

Aircraft Identification and Status

Table with columns: A/C Serial #, A/C Unit #, A/C Registration #, Date, City ID, Total A/C Hours, Total A/C Landings, Total Engine Hrs, Total Engine Cycles, Total Prop Hrs

Component Changes, Inspections, Service Bulletins, or Airworthiness Directives Accomplished

Table with columns: Item, Transaction No. Type, Item Name, Position, Part Number / Alternate Part Number, Mod Level, Part Serial, Removal Reason, Installed Part Status TSN/TSO/TSR, Material Costs, Man Hours

Trans. Type: 1 - Component, 2 - Inspection, 3 - SB, 4 - AD, - - Misc.

Removal Reasons: WO - Worn to Limits, SC - Scheduled, UN - Unscheduled, CO - Convenience, N - Other(note in comments)

Installed Part Status: N - New, R - Repaired/Rebuilt, S - Serviceable, O - Overhauled

Main repair form containing fields for Repair Facility, Certified Repair Station Number, Work Order No., Work Performed By, Certificate No., Date, and Work Inspected By.

Maintenance Log table with columns: Book, Page



Maintenance Transaction Record



This Maintenance Report is To Be Used Solely For (Check One)

Airframe Entries Eng. Serial No. PCE-VA0103 Prop. Serial No. BUA32866

CAMP Systems International
8200 E. 34TH STREET
BUILDING 1600, SUITE 1607
Wichita, KS 67226
Phone: 316-462-2267/ Fax: 316-462-0791

Aircraft Identification and Status

Table with columns: A/C Serial #, A/C Unit #, A/C Registration #, Date, City ID, Total A/C Hours, Total A/C Landings, Total Engine Hrs, Total Engine Cycles, Total Prop Hrs. Row 1: 208B-5098, RP-C1087, 17-Aug-2017, RPLB, 1544.3, 2280, 1544.3, 2280, 1544.3

Component Changes, Inspections, Service Bulletins, or Airworthiness Directives Accomplished

Table with columns: Item, Transaction No. Type, Item Name, Position, Part Number / Alternate Part Number, Mod Level, Part Serial, Removal Reason, Installed Part Status TSN/TSO/TSR, Material Costs, Man Hours. Includes transactions 051265 and 710055 with detailed descriptions.

Trans. Type: 1 - Component, 2 - Inspection, 3 - SB, 4 - AD, - - Misc.

Removal Reasons: WO - Worn to Limits, SC - Scheduled, UN - Unscheduled, CO - Convenience, N - Other(note in comments)

Installed Part Status: N - New, R - Repaired/Rebuilt, S - Serviceable, O - Overhauled

Repair Facility, Certified Repair Station Number, Work Order No. 170231, Work Performed By ERIC DE LEON, Certificate No. 110359-AMT, Date 17-Aug-2017. Includes certification text and Work Inspected By JAYSON RAMOS, Certificate No. 110593-AMT, Date 17-Aug-2017.

Maintenance Log table with columns: Book, Page



Maintenance Transaction Record



This Maintenance Report is To Be Used Solely For (Check One)

Airframe Entries Eng. Serial No. PCE-VA0103 Prop. Serial No. BUA32866

CAMP Systems International
8200 E. 34TH STREET
BUILDING 1600, SUITE 1607
Wichita, KS 67226
Phone: 316-462-2267/ Fax: 316-462-0791

Aircraft Identification and Status

Table with columns: A/C Serial #, A/C Unit #, A/C Registration #, Date, City ID, Total A/C Hours, Total A/C Landings, Total Engine Hrs, Total Engine Cycles, Total Prop Hrs. Row 1: 208B-5098, RP-C1087, 13-Aug-2017, RPLB, 1541.1, 2276, 1541.1, 2276, 1541.1

Component Changes, Inspections, Service Bulletins, or Airworthiness Directives Accomplished

Table with columns: Item, Transaction No. Type, Item Name, Position, Part Number / Alternate Part Number, Mod Level, Part Serial, Removal Reason, Installed Part Status TSN/TSO/TSR, Material Costs, Man Hours. Row 1: 053417, 1 2, UPDATE NAV DATABASE, Comments: C/OUT NAV DATABASE UPDATE IAW GARMIN G100 MM PER 053417 TASK. SATISFACTORY.

Trans. Type: 1 - Component, 2 - Inspection, 3 - SB, 4 - AD, - - Misc.

Removal Reasons: WO - Worn to Limits, SC - Scheduled, UN - Unscheduled, CO - Convenience, N - Other(note in comments)

Installed Part Status: N - New, R - Repaired/Rebuilt, S - Serviceable, O - Overhauled

Repair Facility, Certified Repair Station Number, Work Order No. S17318, Date 13-Aug-2017. I certify that the above stated maintenance and/or inspection was performed in accordance with the current regulations of the Federal Aviation Administration and CAAP. THE AIRCRAFT IDENTIFIED ABOVE IS PRESENTLY AIRWORTHY AND APPROVED FOR RETURN TO SERVICE.

Maintenance Log table with columns: Book, Page



Maintenance Transaction Record



This Maintenance Report is To Be Used Solely For (Check One)

Airframe Entries Eng. Serial No. PCE-VA0103 Prop. Serial No. BUA32866

CAMP Systems International
8200 E. 34TH STREET
BUILDING 1600, SUITE 1607
Wichita, KS 67226
Phone: 316-462-2267/ Fax: 316-462-0791

Aircraft Identification and Status

Table with columns: A/C Serial #, A/C Unit #, A/C Registration #, Date, City ID, Total A/C Hours, Total A/C Landings, Total Engine Hrs, Total Engine Cycles, Total Prop Hrs. Row 1: 208B-5098, RP-C1087, 11-Aug-2017, RPLB, 1464.3, 2146, 1464.3, 2146, 1464.3

Component Changes, Inspections, Service Bulletins, or Airworthiness Directives Accomplished

Table with columns: Item, Transaction No. Type, Item Name, Position, Part Number / Alternate Part Number, Mod Level, Part Serial, Removal Reason, Installed Part Status TSN/TSO/TSR, Material Costs, Man Hours. Row 1: 350301, 1 1, CENTER OXYGEN 50.67 CU FT AND 116.95 CU FT CYLINDER, CENTER, N/A, N/A, N, T, 1 MTH. Comments: NOT APPLICABLE - NO OXYGEN INSTALLED

Trans. Type: 1 - Component, 2 - Inspection, 3 - SB, 4 - AD, - - Misc.

Removal Reasons: WO - Worn to Limits, SC - Scheduled, UN - Unscheduled, CO - Convenience, N - Other(note in comments)

Installed Part Status: N - New, R - Repaired/Rebuilt, S - Serviceable, O - Overhauled

Repair Facility, Certified Repair Station Number, Work Order No. S17230, Date 06-Jul-2017. I certify that the above stated maintenance and/or inspection was performed in accordance with the current regulations of the Federal Aviation Administration and Other (Specify) CAAP. THE AIRCRAFT IDENTIFIED ABOVE IS PRESENTLY AIRWORTHY AND APPROVED FOR RETURN TO SERVICE.

Maintenance Log table with columns: Book, Page



Maintenance Transaction Record



This Maintenance Report is To Be Used Solely For (Check One)

Airframe Entries Eng. Serial No. PCE-VA0103 Prop. Serial No. BUA32866

CAMP Systems International
8200 E. 34TH STREET
BUILDING 1600, SUITE 1607
Wichita, KS 67226
Phone: 316-462-2267/ Fax: 316-462-0791

Aircraft Identification and Status

Table with columns: A/C Serial #, A/C Unit #, A/C Registration #, Date, City ID, Total A/C Hours, Total A/C Landings, Total Engine Hrs, Total Engine Cycles, Total Prop Hrs. Row 1: 208B-5098, RP-C1087, 11-Aug-2017, RPLL, 713.9, 884, 713.9, 884, 713.9

Component Changes, Inspections, Service Bulletins, or Airworthiness Directives Accomplished

Table with columns: Item, Transaction No. Type, Item Name, Position, Part Number / Alternate Part Number, Mod Level, Part Serial, Removal Reason, Installed Part Status TSN/TSO/TSR, Material Costs, Man Hours. Row 1: CAL-28-01 R1, 1 3, FUEL - INSPECTION/ REPLACEMENT OF LEFT LOW FUEL LEVEL SWITCH COVER ASSEMBLY, SERVICE LETTER, MOC: COMPLIED WITH, Comments: C/OUT INSP. IAW SL CAL-28-01 R1 FUEL INSPECTION / REPLACEMENT OF LEFT LOW FUEL LEVEL SWITCH COVER ASSEMBLY. SATISFACTORY

Trans. Type: 1 - Component, 2 - Inspection, 3 - SB, 4 - AD, - - Misc.

Removal Reasons: WO - Worn to Limits, SC - Scheduled, UN - Unscheduled, CO - Convenience, N - Other(note in comments)

Installed Part Status: N - New, R - Repaired/Rebuilt, S - Serviceable, O - Overhauled

Repair Facility, Certified Repair Station Number, Work Order No. 160011/ AML 0036, Work Performed By DAVE BANARES, Certificate No. 114533-AMT, Date 12-Jan-2017. I certify that the above stated maintenance and/or inspection was performed in accordance with the current regulations of the Federal Aviation Administration and Other (Specify) CAAP. THE AIRCRAFT IDENTIFIED ABOVE IS PRESENTLY AIRWORTHY AND APPROVED FOR RETURN TO SERVICE. Work Inspected By NESTOR DERPO, Certificate No. 119184-AMT, Date 12-Jan-2017. Pertinent details of this maintenance are on file at our facility under the above Work/Service Order Number as applicable.

Maintenance Log table with columns: Book, Page



Maintenance Transaction Record



This Maintenance Report is To Be Used Solely For (Check One)

Form with checkboxes for Airframe Entries, Eng. Serial No. (PCE-VA0103), and Prop. Serial No. (BUA32866)

CAMP Systems International
8200 E. 34TH STREET
BUILDING 1600, SUITE 1607
Wichita, KS 67226
Phone: 316-462-2267/ Fax: 316-462-0791

Aircraft Identification and Status

Table with columns: A/C Serial #, A/C Unit #, A/C Registration #, Date, City ID, Total A/C Hours, Total A/C Landings, Total Engine Hrs, Total Engine Cycles, Total Prop Hrs

Component Changes, Inspections, Service Bulletins, or Airworthiness Directives Accomplished

Table with columns: Item, Transaction No. Type, Item Name, Position, Part Number / Alternate Part Number, Mod Level, Part Serial, Removal Reason, Installed Part Status TSN/TSO/TSR, Material Costs, Man Hours

Trans. Type: 1 - Component, 2 - Inspection, 3 - SB, 4 - AD, - - Misc.

Removal Reasons: WO - Worn to Limits, SC - Scheduled, UN - Unscheduled, CO - Convenience, N - Other(note in comments)

Installed Part Status: N - New, R - Repaired/Rebuilt, S - Serviceable, O - Overhauled

Repair Facility form containing fields for Certified Repair Station Number, Work Order No., Work Performed By, Date, and Work Inspected By.

Maintenance Log table with columns: Book, Page



Maintenance Transaction Record



This Maintenance Report is To Be Used Solely For (Check One)

Airframe Entries Eng. Serial No. PCE-VA0103 Prop. Serial No. BUA32866

CAMP Systems International
8200 E. 34TH STREET
BUILDING 1600, SUITE 1607
Wichita, KS 67226
Phone: 316-462-2267/ Fax: 316-462-0791

Aircraft Identification and Status

Table with columns: A/C Serial #, A/C Unit #, A/C Registration #, Date, City ID, Total A/C Hours, Total A/C Landings, Total Engine Hrs, Total Engine Cycles, Total Prop Hrs. Row 1: 208B-5098, RP-C1087, 02-Aug-2017, RPLB, 1514.5, 2234, 1514.5, 2234, 1514.5

Component Changes, Inspections, Service Bulletins, or Airworthiness Directives Accomplished

Table with columns: Item, Transaction No. Type, Item Name, Position, Part Number / Alternate Part Number, Mod Level, Part Serial, Removal Reason, Installed Part Status TSN/TSO/TSR, Material Costs, Man Hours. Row 1: 053417, 1 2, UPDATE NAV DATABASE, Comments: C/OUT NAV DATABASE UPDATE IAW GARMIN G1000 PILOT'S GUIDE CESSNA NAV III REV. A SECTIONS APPENDIX PP. 584-587. SATISFACTORY

Trans. Type: 1 - Component, 2 - Inspection, 3 - SB, 4 - AD, - - Misc.

Removal Reasons: WO - Worn to Limits, SC - Scheduled, UN - Unscheduled, CO - Convenience, N - Other(note in comments)

Installed Part Status: N - New, R - Repaired/Rebuilt, S - Serviceable, O - Overhauled

Repair Facility, Certified Repair Station Number, Work Order No., Work Performed By, ARIEL JASON DAYRIT, Certificate No. 102495-AMT, Date 02-Aug-2017. I certify that the above stated maintenance and/or inspection was performed in accordance with the current regulations of the Federal Aviation Administration and Other (Specify) CAAP. THE AIRCRAFT IDENTIFIED ABOVE IS PRESENTLY AIRWORTHY AND APPROVED FOR RETURN TO SERVICE. Work Inspected By, JAYSON RAMOS, Certificate No. 110593-AMT, Date 02-Aug-2017. Pertinent details of this maintenance are on file at our facility under the above Work/Service Order Number as applicable.

Maintenance Log table with columns: Book, Page



Maintenance Transaction Record



This Maintenance Report is To Be Used Solely For (Check One)

Airframe Entries Eng. Serial No. PCE-VA0103 Prop. Serial No. BUA32866

CAMP Systems International
8200 E. 34TH STREET
BUILDING 1600, SUITE 1607
Wichita, KS 67226
Phone: 316-462-2267/ Fax: 316-462-0791

Aircraft Identification and Status

Table with columns: A/C Serial #, A/C Unit #, A/C Registration #, Date, City ID, Total A/C Hours, Total A/C Landings, Total Engine Hrs, Total Engine Cycles, Total Prop Hrs. Row 1: 208B-5098, RP-C1087, 24-Jul-2017, RPLB, 1504.7, 2216, 1504.7, 2216, 1504.7

Component Changes, Inspections, Service Bulletins, or Airworthiness Directives Accomplished

Table with columns: Item, Transaction No. Type, Item Name, Position, Part Number / Alternate Part Number, Mod Level, Part Serial, Removal Reason, Installed Part Status TSN/TSO/TSR, Material Costs, Man Hours. Row 1: 5-15-07, 1 2, INSPECTION DOCUMENT 07, Comments: C/OUT INSPECTION DOCUMENT 07 PER C208B MM CHAP 5-15-07. SATISFACTORY

Trans. Type: 1 - Component, 2 - Inspection, 3 - SB, 4 - AD, - - Misc.

Removal Reasons: WO - Worn to Limits, SC - Scheduled, UN - Unscheduled, CO - Convenience, N - Other(note in comments)

Installed Part Status: N - New, R - Repaired/Rebuilt, S - Serviceable, O - Overhauled

Repair Facility, Certified Repair Station Number, Work Order No. S17287, Work Performed By ERIC DE LEON, Certificate No. 110359-AMT, Date 24-Jul-2017. I certify that the above stated maintenance and/or inspection was performed in accordance with the current regulations of the Federal Aviation Administration and Other (Specify) CAAP. THE AIRCRAFT IDENTIFIED ABOVE IS PRESENTLY AIRWORTHY AND APPROVED FOR RETURN TO SERVICE. Work Inspected By JAYSON I RAMOS, Certificate No. 110593-AMT, Date 24-Jul-2017. Pertinent details of this maintenance are on file at our facility under the above Work/Service Order Number as applicable.

Maintenance Log table with columns: Book, Page



Maintenance Transaction Record



This Maintenance Report is To Be Used Solely For (Check One)

Airframe Entries Eng. Serial No. PCE-VA0103 Prop. Serial No. BUA32866

CAMP Systems International
8200 E. 34TH STREET
BUILDING 1600, SUITE 1607
Wichita, KS 67226
Phone: 316-462-2267/ Fax: 316-462-0791

Aircraft Identification and Status

Table with columns: A/C Serial #, A/C Unit #, A/C Registration #, Date, City ID, Total A/C Hours, Total A/C Landings, Total Engine Hrs, Total Engine Cycles, Total Prop Hrs. Row 1: 208B-5098, RP-C1087, 06-Jul-2017, RPLB, 1464.3, 2146, 1464.3, 2146, 1464.3

Component Changes, Inspections, Service Bulletins, or Airworthiness Directives Accomplished

Table with columns: Item, Transaction No. Type, Item Name, Position, Part Number / Alternate Part Number, Mod Level, Part Serial, Removal Reason, Installed Part Status TSN/TSO/TSR, Material Costs, Man Hours. Rows include FAA 2016-11-20 and FAA 2017-04-06.

Trans. Type: 1 - Component, 2 - Inspection, 3 - SB, 4 - AD, -- Misc.

Removal Reasons: WO - Worn to Limits, SC - Scheduled, UN - Unscheduled, CO - Convenience, N - Other(note in comments)

Installed Part Status: N - New, R - Repaired/Rebuilt, S - Serviceable, O - Overhauled

Repair Facility, Certified Repair Station Number, Work Order No. S17229, Work Performed By JAYSON RAMOS, Certificate No. 110593-AMT, Date 06-Jul-2017. I certify that the above stated maintenance and/or inspection was performed in accordance with the current regulations of the Federal Aviation Administration and Other (Specify) CAAP. THE AIRCRAFT IDENTIFIED ABOVE IS PRESENTLY AIRWORTHY AND APPROVED FOR RETURN TO SERVICE. Work Inspected By KRISTOPHER ALLEN GABISON, Certificate No. 110205-AMT, Date 06-Jul-2017.

Maintenance Log table with columns: Book, Page



Maintenance Transaction Record



This Maintenance Report is To Be Used Solely For (Check One)

Airframe Entries Eng. Serial No. PCE-VA0103 Prop. Serial No. BUA32866

CAMP Systems International
8200 E. 34TH STREET
BUILDING 1600, SUITE 1607
Wichita, KS 67226
Phone: 316-462-2267/ Fax: 316-462-0791

Aircraft Identification and Status

Table with columns: A/C Serial #, A/C Unit #, A/C Registration #, Date, City ID, Total A/C Hours, Total A/C Landings, Total Engine Hrs, Total Engine Cycles, Total Prop Hrs. Row 1: 208B-5098, RP-C1087, 06-Jul-2017, RPLB, 1464.3, 2146, 1464.3, 2146, 1464.3

Component Changes, Inspections, Service Bulletins, or Airworthiness Directives Accomplished

Table with columns: Item, Transaction No. Type, Item Name, Position, Part Number / Alternate Part Number, Mod Level, Part Serial, Removal Reason, Installed Part Status TSN/TSO/TSR, Material Costs, Man Hours. Row 1: 350004, 1 2, HYDROSTATIC TEST CENTER OXYGEN 50.67 CU FT AND 116.95 CU FT CYLINDER (DOT-E 8162), CENTER, PN, SN-UNKNOWN, Hydro Check Date: 06-Jul-2017, Comments: N/A - NO OXYGEN INSTALLED

Trans. Type: 1 - Component, 2 - Inspection, 3 - SB, 4 - AD, - - Misc.

Removal Reasons: WO - Worn to Limits, SC - Scheduled, UN - Unscheduled, CO - Convenience, N - Other(note in comments)

Installed Part Status: N - New, R - Repaired/Rebuilt, S - Serviceable, O - Overhauled

Repair Facility, Certified Repair Station Number, Work Order No., Work Performed By ERIC DE LEON, Certificate No. 110359-AMT, Date 06-Jul-2017. I certify that the above stated maintenance and/or inspection was performed in accordance with the current regulations of the Federal Aviation Administration and THE AIRCRAFT IDENTIFIED ABOVE IS PRESENTLY AIRWORTHY AND APPROVED FOR RETURN TO SERVICE. Work Inspected By JAYSON I RAMOS, Certificate No. 110593-AMT, Date 06-Jul-2017. Pertinent details of this maintenance are on file at our facility under the above Work/Service Order Number as applicable.

Maintenance Log table with columns: Book, Page



Maintenance Transaction Record



This Maintenance Report is To Be Used Solely For (Check One)

Airframe Entries Eng. Serial No. PCE-VA0103 Prop. Serial No. BUA32866

CAMP Systems International
8200 E. 34TH STREET
BUILDING 1600, SUITE 1607
Wichita, KS 67226
Phone: 316-462-2267/ Fax: 316-462-0791

Aircraft Identification and Status

Table with columns: A/C Serial #, A/C Unit #, A/C Registration #, Date, City ID, Total A/C Hours, Total A/C Landings, Total Engine Hrs, Total Engine Cycles, Total Prop Hrs. Row 1: 208B-5098, RP-C1087, 06-Jul-2017, RPLB, 1464.3, 2146, 1464.3, 2146, 1464.3

Component Changes, Inspections, Service Bulletins, or Airworthiness Directives Accomplished

Table with columns: Item, Transaction No. Type, Item Name, Position, Part Number / Alternate Part Number, Mod Level, Part Serial, Removal Reason, Installed Part Status TSN/TSO/TSR, Material Costs, Man Hours. Rows for items 051260 and 051265, both describing inspection of floats.

Trans. Type: 1 - Component, 2 - Inspection, 3 - SB, 4 - AD, - - Misc.

Removal Reasons: WO - Worn to Limits, SC - Scheduled, UN - Unscheduled, CO - Convenience, N - Other(note in comments)

Installed Part Status: N - New, R - Repaired/Rebuilt, S - Serviceable, O - Overhauled

Repair Facility, Certified Repair Station Number, Work Order No., Work Performed By ERIC DE LEON, Certificate No. 110359-AMT, Date 06-Jul-2017. I certify that the above stated maintenance and/or inspection was performed in accordance with the current regulations of the Federal Aviation Administration and THE AIRCRAFT IDENTIFIED ABOVE IS PRESENTLY AIRWORTHY AND APPROVED FOR RETURN TO SERVICE. Work Inspected By JAYSON I RAMOS, Certificate No. 110593-AMT, Date 06-Jul-2017.

Maintenance Log table with columns: Book, Page



Maintenance Transaction Record



This Maintenance Report is To Be Used Solely For (Check One)

Airframe Entries Eng. Serial No. PCE-VA0103 Prop. Serial No. BUA32866

CAMP Systems International
8200 E. 34TH STREET
BUILDING 1600, SUITE 1607
Wichita, KS 67226
Phone: 316-462-2267/ Fax: 316-462-0791

Aircraft Identification and Status

Table with columns: A/C Serial #, A/C Unit #, A/C Registration #, Date, City ID, Total A/C Hours, Total A/C Landings, Total Engine Hrs, Total Engine Cycles, Total Prop Hrs. Row 1: 208B-5098, RP-C1087, 06-Jul-2017, RPLB, 1464.3, 2146, 1464.3, 2146, 1464.3

Component Changes, Inspections, Service Bulletins, or Airworthiness Directives Accomplished

Table with columns: Item, Transaction No. Type, Item Name, Position, Part Number / Alternate Part Number, Mod Level, Part Serial, Removal Reason, Installed Part Status TSN/TSO/TSR, Material Costs, Man Hours. Row 1: 051260, 1 2, INSPECT 25 HR INSP-FLOATS, Comments: C/OUT 25 HOURS FLOAT INSPECTION IAW WIPAIRE 8750 MM PAGE 86 TO 89...SATISFACTORY

Trans. Type: 1 - Component, 2 - Inspection, 3 - SB, 4 - AD, - - Misc.

Removal Reasons: WO - Worn to Limits, SC - Scheduled, UN - Unscheduled, CO - Convenience, N - Other(note in comments)

Installed Part Status: N - New, R - Repaired/Rebuilt, S - Serviceable, O - Overhauled

Repair Facility, Certified Repair Station Number, Work Order No. S17234, Date 06-Jul-2017. I certify that the above stated maintenance and/or inspection was performed in accordance with the current regulations of the Federal Aviation Administration and CAAP. THE AIRCRAFT IDENTIFIED ABOVE IS PRESENTLY AIRWORTHY AND APPROVED FOR RETURN TO SERVICE.

Maintenance Log table with columns: Book, Page



Maintenance Transaction Record



This Maintenance Report is To Be Used Solely For (Check One)

Airframe Entries Eng. Serial No. PCE-VA0103 Prop. Serial No. BUA32866

CAMP Systems International
8200 E. 34TH STREET
BUILDING 1600, SUITE 1607
Wichita, KS 67226
Phone: 316-462-2267/ Fax: 316-462-0791

Aircraft Identification and Status

Table with columns: A/C Serial #, A/C Unit #, A/C Registration #, Date, City ID, Total A/C Hours, Total A/C Landings, Total Engine Hrs, Total Engine Cycles, Total Prop Hrs. Row 1: 208B-5098, RP-C1087, 29-Jun-2017, RPLB, 1446.3, 2117, 1446.3, 2117, 1446.3

Component Changes, Inspections, Service Bulletins, or Airworthiness Directives Accomplished

Table with columns: Item, Transaction No. Type, Item Name, Position, Part Number / Alternate Part Number, Mod Level, Part Serial, Removal Reason, Installed Part Status TSN/TSO/TSR, Material Costs, Man Hours. Rows include inspection items 051260 and 051265.

Trans. Type: 1 - Component, 2 - Inspection, 3 - SB, 4 - AD, - - Misc.

Removal Reasons: WO - Worn to Limits, SC - Scheduled, UN - Unscheduled, CO - Convenience, N - Other(note in comments)

Installed Part Status: N - New, R - Repaired/Rebuilt, S - Serviceable, O - Overhauled

Repair Facility, Certified Repair Station Number, Work Order No. S17208, Work Performed By MARK GERSHON U TARAY, Certificate No. 114778-AMT, Date 29-Jun-2017. Includes certification text and Work Inspected By JAYSON I RAMOS, Certificate No. 110593-AMT, Date 29-Jun-2017.

Maintenance Log table with columns: Book, Page



Maintenance Transaction Record



This Maintenance Report is To Be Used Solely For (Check One)

Form with checkboxes for Airframe Entries, Eng. Serial No., and Prop. Serial No.

CAMP Systems International
8200 E. 34TH STREET
BUILDING 1600, SUITE 1607
Wichita, KS 67226
Phone: 316-462-2267/ Fax: 316-462-0791

Aircraft Identification and Status

Table with columns: A/C Serial #, A/C Unit #, A/C Registration #, Date, City ID, Total A/C Hours, Total A/C Landings, Total Engine Hrs, Total Engine Cycles, Total Prop Hrs

Component Changes, Inspections, Service Bulletins, or Airworthiness Directives Accomplished

Table with columns: Item, Transaction No. Type, Item Name, Position, Part Number / Alternate Part Number, Mod Level, Part Serial, Removal Reason, Installed Part Status TSN/TSO/TSR, Material Costs, Man Hours

Trans. Type: 1 - Component, 2 - Inspection, 3 - SB, 4 - AD, - - Misc.

Removal Reasons: WO - Worn to Limits, SC - Scheduled, UN - Unscheduled, CO - Convenience, N - Other(note in comments)

Installed Part Status: N - New, R - Repaired/Rebuilt, S - Serviceable, O - Overhauled

Main repair form containing fields for Repair Facility, Certified Repair Station Number, Work Order No., Work Performed By, Certificate No., Date, and Work Inspected By.

Maintenance Log table with columns: Book, Page



Maintenance Transaction Record



This Maintenance Report is To Be Used Solely For (Check One)

Form with checkboxes for Airframe Entries, Eng. Serial No., and Prop. Serial No.

CAMP Systems International
8200 E. 34TH STREET
BUILDING 1600, SUITE 1607
Wichita, KS 67226
Phone: 316-462-2267/ Fax: 316-462-0791

Aircraft Identification and Status

Table with columns: A/C Serial #, A/C Unit #, A/C Registration #, Date, City ID, Total A/C Hours, Total A/C Landings, Total Engine Hrs, Total Engine Cycles, Total Prop Hrs

Component Changes, Inspections, Service Bulletins, or Airworthiness Directives Accomplished

Table with columns: Item, Transaction No. Type, Item Name, Position, Part Number / Alternate Part Number, Mod Level, Part Serial, Removal Reason, Installed Part Status TSN/TSO/TSR, Material Costs, Man Hours

Trans. Type: 1 - Component, 2 - Inspection, 3 - SB, 4 - AD, - - Misc.

Removal Reasons: WO - Worn to Limits, SC - Scheduled, UN - Unscheduled, CO - Convenience, N - Other(note in comments)

Installed Part Status: N - New, R - Repaired/Rebuilt, S - Serviceable, O - Overhauled

Main repair record form containing fields for Repair Facility, Certified Repair Station Number, Work Order No., Work Performed By, Certificate No., Date, and Work Inspected By.

Maintenance Log table with columns: Book, Page



Maintenance Transaction Record



This Maintenance Report is To Be Used Solely For (Check One)

Form with checkboxes for Airframe Entries, Eng. Serial No., and Prop. Serial No.

CAMP Systems International
8200 E. 34TH STREET
BUILDING 1600, SUITE 1607
Wichita, KS 67226
Phone: 316-462-2267/ Fax: 316-462-0791

Aircraft Identification and Status

Table with columns: A/C Serial #, A/C Unit #, A/C Registration #, Date, City ID, Total A/C Hours, Total A/C Landings, Total Engine Hrs, Total Engine Cycles, Total Prop Hrs.

Component Changes, Inspections, Service Bulletins, or Airworthiness Directives Accomplished

Table with columns: Item, Transaction No. Type, Item Name, Position, Part Number / Alternate Part Number, Mod Level, Part Serial, Removal Reason, Installed Part Status TSN/TSO/TSR, Material Costs, Man Hours.

Trans. Type: 1 - Component, 2 - Inspection, 3 - SB, 4 - AD, -- Misc.

Removal Reasons: WO - Worn to Limits, SC - Scheduled, UN - Unscheduled, CO - Convenience, N - Other(note in comments)

Installed Part Status: N - New, R - Repaired/Rebuilt, S - Serviceable, O - Overhauled

Main repair form containing fields for Repair Facility, Certified Repair Station Number, Work Order No., Work Performed By, Certificate No., Date, and Work Inspected By.

Maintenance Log table with columns: Book, Page.



Maintenance Transaction Record



This Maintenance Report is To Be Used Solely For (Check One)

Form with checkboxes for Airframe Entries, Eng. Serial No., and Prop. Serial No.

CAMP Systems International
8200 E. 34TH STREET
BUILDING 1600, SUITE 1607
Wichita, KS 67226
Phone: 316-462-2267/ Fax: 316-462-0791

Aircraft Identification and Status

Table with columns: A/C Serial #, A/C Unit #, A/C Registration #, Date, City ID, Total A/C Hours, Total A/C Landings, Total Engine Hrs, Total Engine Cycles, Total Prop Hrs.

Component Changes, Inspections, Service Bulletins, or Airworthiness Directives Accomplished

Table with columns: Item, Transaction No. Type, Item Name, Position, Part Number / Alternate Part Number, Mod Level, Part Serial, Removal Reason, Installed Part Status TSN/TSO/TSR, Material Costs, Man Hours.

Trans. Type: 1 - Component, 2 - Inspection, 3 - SB, 4 - AD, -- Misc.

Removal Reasons: WO - Worn to Limits, SC - Scheduled, UN - Unscheduled, CO - Convenience, N - Other(note in comments)

Installed Part Status: N - New, R - Repaired/Rebuilt, S - Serviceable, O - Overhauled

Main repair form containing fields for Repair Facility, Certified Repair Station Number, Work Order No., Work Performed By, Certificate No., Date, and Work Inspected By.

Maintenance Log table with columns: Book, Page.



Maintenance Transaction Record



This Maintenance Report is To Be Used Solely For (Check One)

Form with checkboxes for Airframe Entries, Eng. Serial No., and Prop. Serial No.

CAMP Systems International
8200 E. 34TH STREET
BUILDING 1600, SUITE 1607
Wichita, KS 67226
Phone: 316-462-2267/ Fax: 316-462-0791

Aircraft Identification and Status

Table with columns: A/C Serial #, A/C Unit #, A/C Registration #, Date, City ID, Total A/C Hours, Total A/C Landings, Total Engine Hrs, Total Engine Cycles, Total Prop Hrs.

Component Changes, Inspections, Service Bulletins, or Airworthiness Directives Accomplished

Table with columns: Item, Transaction No. Type, Item Name, Position, Part Number / Alternate Part Number, Mod Level, Part Serial, Removal Reason, Installed Part Status TSN/TSO/TSR, Material Costs, Man Hours.

Trans. Type: 1 - Component, 2 - Inspection, 3 - SB, 4 - AD, - - Misc.

Removal Reasons: WO - Worn to Limits, SC - Scheduled, UN - Unscheduled, CO - Convenience, N - Other(note in comments)

Installed Part Status: N - New, R - Repaired/Rebuilt, S - Serviceable, O - Overhauled

Main repair form containing fields for Repair Facility, Certified Repair Station Number, Work Order No., Work Performed By, Date, and Work Inspected By.

Maintenance Log table with columns: Book, Page.



Maintenance Transaction Record



This Maintenance Report is To Be Used Solely For (Check One)

Form with checkboxes for Airframe Entries, Eng. Serial No., and Prop. Serial No.

CAMP Systems International
8200 E. 34TH STREET
BUILDING 1600, SUITE 1607
Wichita, KS 67226
Phone: 316-462-2267/ Fax: 316-462-0791

Aircraft Identification and Status

Table with columns: A/C Serial #, A/C Unit #, A/C Registration #, Date, City ID, Total A/C Hours, Total A/C Landings, Total Engine Hrs, Total Engine Cycles, Total Prop Hrs

Component Changes, Inspections, Service Bulletins, or Airworthiness Directives Accomplished

Main table with columns: Item, Transaction No. Type, Item Name, Position, Part Number / Alternate Part Number, Mod Level, Part Serial, Removal Reason, Installed Part Status, Material Costs, Man Hours

Trans. Type: 1 - Component, 2 - Inspection, 3 - SB, 4 - AD, - - Misc.

Removal Reasons: WO - Worn to Limits, SC - Scheduled, UN - Unscheduled, CO - Convenience, N - Other(note in comments)

Installed Part Status: N - New, R - Repaired/Rebuilt, S - Serviceable, O - Overhauled

Repair Facility, Certified Repair Station Number, Work Order No., Work Performed By, Date, and Work Inspected By fields.

Maintenance Log table with columns: Book, Page



Maintenance Transaction Record



This Maintenance Report is To Be Used Solely For (Check One)

Form with checkboxes for Airframe Entries, Eng. Serial No., and Prop. Serial No.

CAMP Systems International
8200 E. 34TH STREET
BUILDING 1600, SUITE 1607
Wichita, KS 67226
Phone: 316-462-2267/ Fax: 316-462-0791

Aircraft Identification and Status

Table with columns: A/C Serial #, A/C Unit #, A/C Registration #, Date, City ID, Total A/C Hours, Total A/C Landings, Total Engine Hrs, Total Engine Cycles, Total Prop Hrs.

Component Changes, Inspections, Service Bulletins, or Airworthiness Directives Accomplished

Table with columns: Item, Transaction No., Type, Item Name, Position, Part Number / Alternate Part Number, Mod Level, Part Serial, Removal Reason, Installed Part Status, TSN/TSO/TSR, Material Costs, Man Hours.

Trans. Type: 1 - Component, 2 - Inspection, 3 - SB, 4 - AD, - - Misc.

Removal Reasons: WO - Worn to Limits, SC - Scheduled, UN - Unscheduled, CO - Convenience, N - Other(note in comments)

Installed Part Status: N - New, R - Repaired/Rebuilt, S - Serviceable, O - Overhauled

Repair Facility form containing fields for Facility, Certified Repair Station Number, Work Order No., Work Performed By, Certificate No., Date, and Work Inspected By.

Maintenance Log table with columns: Book, Page.



Maintenance Transaction Record



This Maintenance Report is To Be Used Solely For (Check One)

Form with checkboxes for Airframe Entries, Eng. Serial No., and Prop. Serial No.

CAMP Systems International
8200 E. 34TH STREET
BUILDING 1600, SUITE 1607
Wichita, KS 67226
Phone: 316-462-2267/ Fax: 316-462-0791

Aircraft Identification and Status

Table with columns: A/C Serial #, A/C Unit #, A/C Registration #, Date, City ID, Total A/C Hours, Total A/C Landings, Total Engine Hrs, Total Engine Cycles, Total Prop Hrs

Component Changes, Inspections, Service Bulletins, or Airworthiness Directives Accomplished

Table with columns: Item, Transaction No. Type, Item Name, Position, Part Number / Alternate Part Number, Mod Level, Part Serial, Removal Reason, Installed Part Status TSN/TSO/TSR, Material Costs, Man Hours

Trans. Type: 1 - Component, 2 - Inspection, 3 - SB, 4 - AD, - - Misc.

Removal Reasons: WO - Worn to Limits, SC - Scheduled, UN - Unscheduled, CO - Convenience, N - Other(note in comments)

Installed Part Status: N - New, R - Repaired/Rebuilt, S - Serviceable, O - Overhauled

Main repair form containing fields for Repair Facility, Certified Repair Station Number, Work Order No., Work Performed By, Date, and Work Inspected By.

Maintenance Log table with columns: Book, Page



Maintenance Transaction Record



This Maintenance Report is To Be Used Solely For (Check One)

Form with checkboxes for Airframe Entries, Eng. Serial No., and Prop. Serial No.

CAMP Systems International
8200 E. 34TH STREET
BUILDING 1600, SUITE 1607
Wichita, KS 67226
Phone: 316-462-2267/ Fax: 316-462-0791

Aircraft Identification and Status

Table with columns: A/C Serial #, A/C Unit #, A/C Registration #, Date, City ID, Total A/C Hours, Total A/C Landings, Total Engine Hrs, Total Engine Cycles, Total Prop Hrs.

Component Changes, Inspections, Service Bulletins, or Airworthiness Directives Accomplished

Table with columns: Item, Transaction No. Type, Item Name, Position, Part Number / Alternate Part Number, Mod Level, Part Serial, Removal Reason, Installed Part Status TSN/TSO/TSR, Material Costs, Man Hours.

Trans. Type: 1 - Component, 2 - Inspection, 3 - SB, 4 - AD, -- Misc.

Removal Reasons: WO - Worn to Limits, SC - Scheduled, UN - Unscheduled, CO - Convenience, N - Other(note in comments)

Installed Part Status: N - New, R - Repaired/Rebuilt, S - Serviceable, O - Overhauled

Main maintenance report form containing fields for Repair Facility, Certified Repair Station Number, Work Order No., Work Performed By, Date, and Work Inspected By.

Maintenance Log table with columns: Book, Page.



Maintenance Transaction Record



This Maintenance Report is To Be Used Solely For (Check One)

Form with checkboxes for Airframe Entries, Eng. Serial No., and Prop. Serial No.

CAMP Systems International
8200 E. 34TH STREET
BUILDING 1600, SUITE 1607
Wichita, KS 67226
Phone: 316-462-2267/ Fax: 316-462-0791

Aircraft Identification and Status

Table with columns: A/C Serial #, A/C Unit #, A/C Registration #, Date, City ID, Total A/C Hours, Total A/C Landings, Total Engine Hrs, Total Engine Cycles, Total Prop Hrs.

Component Changes, Inspections, Service Bulletins, or Airworthiness Directives Accomplished

Table with columns: Item, Transaction No. Type, Item Name, Position, Part Number / Alternate Part Number, Mod Level, Part Serial, Removal Reason, Installed Part Status TSN/TSO/TSR, Material Costs, Man Hours.

Trans. Type: 1 - Component, 2 - Inspection, 3 - SB, 4 - AD, - - Misc.

Removal Reasons: WO - Worn to Limits, SC - Scheduled, UN - Unscheduled, CO - Convenience, N - Other(note in comments)

Installed Part Status: N - New, R - Repaired/Rebuilt, S - Serviceable, O - Overhauled

Main maintenance report form containing fields for Repair Facility, Certified Repair Station Number, Work Order No., Work Performed By, Certificate No., Date, and Work Inspected By.

Maintenance Log table with columns: Book, Page.



Maintenance Transaction Record



This Maintenance Report is To Be Used Solely For (Check One)

Form with checkboxes for Airframe Entries, Eng. Serial No., and Prop. Serial No.

CAMP Systems International
8200 E. 34TH STREET
BUILDING 1600, SUITE 1607
Wichita, KS 67226
Phone: 316-462-2267/ Fax: 316-462-0791

Aircraft Identification and Status

Table with columns: A/C Serial #, A/C Unit #, A/C Registration #, Date, City ID, Total A/C Hours, Total A/C Landings, Total Engine Hrs, Total Engine Cycles, Total Prop Hrs.

Component Changes, Inspections, Service Bulletins, or Airworthiness Directives Accomplished

Table with columns: Item, Transaction No., Type, Item Name, Position, Part Number / Alternate Part Number, Mod Level, Part Serial, Removal Reason, Installed Part Status, TSN/TSO/TSR, Material Costs, Man Hours.

Trans. Type: 1 - Component, 2 - Inspection, 3 - SB, 4 - AD, - - Misc.

Removal Reasons: WO - Worn to Limits, SC - Scheduled, UN - Unscheduled, CO - Convenience, N - Other(note in comments)

Installed Part Status: N - New, R - Repaired/Rebuilt, S - Serviceable, O - Overhauled

Form for repair details including Facility (SUBIC), Certified Repair Station Number, Work Order No. (S17085), Work Performed By (ARISTEO ALCALA), Certificate No. (115162-AMT), Date (03-Apr-2017), and Work Inspected By (KRISTOFER ALLEN GABISON).

Maintenance Log table with columns: Book, Page.



Maintenance Transaction Record



This Maintenance Report is To Be Used Solely For (Check One)

Form with checkboxes for Airframe Entries, Eng. Serial No., and Prop. Serial No.

CAMP Systems International
8200 E. 34TH STREET
BUILDING 1600, SUITE 1607
Wichita, KS 67226
Phone: 316-462-2267/ Fax: 316-462-0791

Aircraft Identification and Status

Table with columns: A/C Serial #, A/C Unit #, A/C Registration #, Date, City ID, Total A/C Hours, Total A/C Landings, Total Engine Hrs, Total Engine Cycles, Total Prop Hrs.

Component Changes, Inspections, Service Bulletins, or Airworthiness Directives Accomplished

Main table for component changes with columns: Item, Transaction No., Type, Item Name, Position, Part Number / Alternate Part Number, Mod Level, Part Serial, Removal Reason, Installed Part Status, TSN/TSO/TSR, Material Costs, Man Hours.

Trans. Type: 1 - Component, 2 - Inspection, 3 - SB, 4 - AD, -- Misc.

Removal Reasons: WO - Worn to Limits, SC - Scheduled, UN - Unscheduled, CO - Convenience, N - Other(note in comments)

Installed Part Status: N - New, R - Repaired/Rebuilt, S - Serviceable, O - Overhauled

Repair Facility details form including fields for Facility, Certified Repair Station Number, Work Order No., Work Performed By, Date, and Work Inspected By.

Maintenance Log table with columns: Book, Page.



Maintenance Transaction Record



This Maintenance Report is To Be Used Solely For (Check One)

Form with checkboxes for Airframe Entries, Eng. Serial No., and Prop. Serial No.

CAMP Systems International
8200 E. 34TH STREET
BUILDING 1600, SUITE 1607
Wichita, KS 67226
Phone: 316-462-2267/ Fax: 316-462-0791

Aircraft Identification and Status

Table with columns: A/C Serial #, A/C Unit #, A/C Registration #, Date, City ID, Total A/C Hours, Total A/C Landings, Total Engine Hrs, Total Engine Cycles, Total Prop Hrs

Component Changes, Inspections, Service Bulletins, or Airworthiness Directives Accomplished

Table with columns: Item, Transaction No. Type, Item Name, Position, Part Number / Alternate Part Number, Mod Level, Part Serial, Removal Reason, Installed Part Status TSN/TSO/TSR, Material Costs, Man Hours

Trans. Type: 1 - Component, 2 - Inspection, 3 - SB, 4 - AD, - - Misc.

Removal Reasons: WO - Worn to Limits, SC - Scheduled, UN - Unscheduled, CO - Convenience, N - Other(note in comments)

Installed Part Status: N - New, R - Repaired/Rebuilt, S - Serviceable, O - Overhauled

Main repair form containing fields for Repair Facility, Certified Repair Station Number, Work Order No., Work Performed By, Certificate No., Date, and Work Inspected By.

Maintenance Log table with columns: Book, Page



Maintenance Transaction Record



This Maintenance Report is To Be Used Solely For (Check One)

Form with checkboxes for Airframe Entries, Eng. Serial No., and Prop. Serial No.

CAMP Systems International
8200 E. 34TH STREET
BUILDING 1600, SUITE 1607
Wichita, KS 67226
Phone: 316-462-2267/ Fax: 316-462-0791

Aircraft Identification and Status

Table with columns: A/C Serial #, A/C Unit #, A/C Registration #, Date, City ID, Total A/C Hours, Total A/C Landings, Total Engine Hrs, Total Engine Cycles, Total Prop Hrs

Component Changes, Inspections, Service Bulletins, or Airworthiness Directives Accomplished

Table with columns: Item, Transaction No. Type, Item Name, Position, Part Number / Alternate Part Number, Mod Level, Part Serial, Removal Reason, Installed Part Status TSN/TSO/TSR, Material Costs, Man Hours

Trans. Type: 1 - Component, 2 - Inspection, 3 - SB, 4 - AD, - - Misc.

Removal Reasons: WO - Worn to Limits, SC - Scheduled, UN - Unscheduled, CO - Convenience, N - Other(note in comments)

Installed Part Status: N - New, R - Repaired/Rebuilt, S - Serviceable, O - Overhauled

Main repair record form containing fields for Repair Facility, Certified Repair Station Number, Work Order No., Work Performed By, Certificate No., Date, and Work Inspected By.

Maintenance Log table with columns: Book, Page



Maintenance Transaction Record



This Maintenance Report is To Be Used Solely For (Check One)

Form with checkboxes for Airframe Entries, Eng. Serial No., and Prop. Serial No.

CAMP Systems International
8200 E. 34TH STREET
BUILDING 1600, SUITE 1607
Wichita, KS 67226
Phone: 316-462-2267/ Fax: 316-462-0791

Aircraft Identification and Status

Table with columns: A/C Serial #, A/C Unit #, A/C Registration #, Date, City ID, Total A/C Hours, Total A/C Landings, Total Engine Hrs, Total Engine Cycles, Total Prop Hrs

Component Changes, Inspections, Service Bulletins, or Airworthiness Directives Accomplished

Table with columns: Item, Transaction No. Type, Item Name, Position, Part Number / Alternate Part Number, Mod Level, Part Serial, Removal Reason, Installed Part Status TSN/TSO/TSR, Material Costs, Man Hours

Trans. Type: 1 - Component, 2 - Inspection, 3 - SB, 4 - AD, - - Misc.

Removal Reasons: WO - Worn to Limits, SC - Scheduled, UN - Unscheduled, CO - Convenience, N - Other(note in comments)

Installed Part Status: N - New, R - Repaired/Rebuilt, S - Serviceable, O - Overhauled

Main maintenance report form containing fields for Repair Facility, Certified Repair Station Number, Work Order No., Work Performed By, Date, and Work Inspected By.

Maintenance Log table with columns: Book, Page



Maintenance Transaction Record



This Maintenance Report is To Be Used Solely For (Check One)

Form with checkboxes for Airframe Entries, Eng. Serial No., and Prop. Serial No.

CAMP Systems International
8200 E. 34TH STREET
BUILDING 1600, SUITE 1607
Wichita, KS 67226
Phone: 316-462-2267/ Fax: 316-462-0791

Aircraft Identification and Status

Table with columns: A/C Serial #, A/C Unit #, A/C Registration #, Date, City ID, Total A/C Hours, Total A/C Landings, Total Engine Hrs, Total Engine Cycles, Total Prop Hrs.

Component Changes, Inspections, Service Bulletins, or Airworthiness Directives Accomplished

Table with columns: Item, Transaction No. Type, Item Name, Position, Part Number / Alternate Part Number, Mod Level, Part Serial, Removal Reason, Installed Part Status TSN/TSO/TSR, Material Costs, Man Hours.

Trans. Type: 1 - Component, 2 - Inspection, 3 - SB, 4 - AD, - - Misc.

Removal Reasons: WO - Worn to Limits, SC - Scheduled, UN - Unscheduled, CO - Convenience, N - Other(note in comments)

Installed Part Status: N - New, R - Repaired/Rebuilt, S - Serviceable, O - Overhauled

Main repair form containing fields for Repair Facility, Certified Repair Station Number, Work Order No., Work Performed By, Certificate No., Date, and Work Inspected By.

Maintenance Log table with columns: Book, Page.



Maintenance Transaction Record



This Maintenance Report is To Be Used Solely For (Check One)

Airframe Entries Eng. Serial No. _____ Prop. Serial No. _____

CAMP Systems International
8200 E. 34TH STREET
BUILDING 1600, SUITE 1607
Wichita, KS 67226
Phone: 316-462-2267/ Fax: 316-462-0791

Aircraft Identification and Status

A/C Serial #	A/C Unit #	A/C Registration #	Date	City ID	Total A/C Hours	Total A/C Landings	Total Engine Hrs	Total Engine Cycles	Total Prop Hrs			
208B-5098		RP-C1087	16-Jan-2017	RPLB	1125.6	1607	1125.6	1607	1125.6			

Component Changes, Inspections, Service Bulletins, or Airworthiness Directives Accomplished

Item	Transaction No. Type	Item Name	Position	Part Number / Alternate Part Number	Mod Level	Part Serial	Removal Reason	InstalledPart Status TSN/TSO/TSR	Material Costs	Man Hours
CAB-32-04	1 3	LANDING GEAR - MAIN LANDING GEAR TRUNNION AND FAIRING INSPECTION, SERVICE BULLETIN MOC: NOT APPLICABLE Comments:								

Trans. Type: 1 - Component, 2 - Inspection, 3 - SB, 4 - AD, -- Misc.

Removal Reasons: WO - Worn to Limits, SC - Scheduled, UN - Unscheduled, CO - Convenience, N - Other(note in comments)

Installed Part Status: N - New, R - Repaired/Rebuilt, S - Serviceable, O - Overhauled

Repair Facility SUBIC **Certified Repair Station Number** _____ **Work Order No.** NA

Work Performed By ARIEL JASON M. DAYRIT **Certificate No.** 102495-AMT **Date** 16-Jan-2017

I certify that the above stated maintenance and/or inspection was performed in accordance with the current regulations of the
 Federal Aviation Administration Other (Specify) CAAP and

THE AIRCRAFT IDENTIFIED ABOVE IS PRESENTLY AIRWORTHY AND APPROVED FOR RETURN TO SERVICE.

Work Inspected By KRISTOFER ALLEN GABISON **Certificate No.** 110205-AMT **Date** 16-Jan-2017

Pertinent details of this maintenance are on file at our facility under the above Work/Service Order Number as applicable.

Maintenance Log	
Book	Page



Maintenance Transaction Record



This Maintenance Report is To Be Used Solely For (Check One)

Airframe Entries Eng. Serial No. PCE-VA0103 Prop. Serial No. BUA32866

CAMP Systems International
8200 E. 34TH STREET
BUILDING 1600, SUITE 1607
Wichita, KS 67226
Phone: 316-462-2267/ Fax: 316-462-0791

Aircraft Identification and Status

Table with columns: A/C Serial #, A/C Unit #, A/C Registration #, Date, City ID, Total A/C Hours, Total A/C Landings, Total Engine Hrs, Total Engine Cycles, Total Prop Hrs. Row 1: 208B-5098, RP-C1087, 21-Dec-2016, RPLB, 1075.3, 1429, 1075.3, 1429, 1075.3

Component Changes, Inspections, Service Bulletins, or Airworthiness Directives Accomplished

Table with columns: Item, Transaction No. Type, Item Name, Position, Part Number / Alternate Part Number, Mod Level, Part Serial, Removal Reason, Installed Part Status TSN/TSO/TSR, Material Costs, Man Hours. Row 1: 051260, 1 2 INSPECT 25 HR INSP-FLOATS, Comments: Carried out 25 hours Float Inspection IAW Wipaire 8750 Float Service Manual. SATISFACTORY.

Trans. Type: 1 - Component, 2 - Inspection, 3 - SB, 4 - AD, - - Misc.

Removal Reasons: WO - Worn to Limits, SC - Scheduled, UN - Unscheduled, CO - Convenience, N - Other(note in comments)

Installed Part Status: N - New, R - Repaired/Rebuilt, S - Serviceable, O - Overhauled

Repair Facility, Certified Repair Station Number, Work Order No. S16048, Date 21-Dec-2016. Work Performed By JEOMART TONQUIN, Certificate No. 106388-AMT. I certify that the above stated maintenance and/or inspection was performed in accordance with the current regulations of the Federal Aviation Administration and Other (Specify) CAAP. THE AIRCRAFT IDENTIFIED ABOVE IS PRESENTLY AIRWORTHY AND APPROVED FOR RETURN TO SERVICE. Work Inspected By MIKE ANGELO MARTINEZ, Certificate No. 112468-AMT, Date 21-Dec-2016. Pertinent details of this maintenance are on file at our facility under the above Work/Service Order Number as applicable.

Maintenance Log table with columns: Book, Page



Maintenance Transaction Record



This Maintenance Report is To Be Used Solely For (Check One)

Airframe Entries Eng. Serial No. _____ Prop. Serial No. _____

CAMP Systems International
8200 E. 34TH STREET
BUILDING 1600, SUITE 1607
Wichita, KS 67226
Phone: 316-462-2267/ Fax: 316-462-0791

Aircraft Identification and Status

A/C Serial #	A/C Unit #	A/C Registration #	Date	City ID	Total A/C Hours	Total A/C Landings	Total Engine Hrs	Total Engine Cycles	Total Prop Hrs			
208B-5098		RP-C1087	18-Dec-2016	RPLB	1065	1409	1065	1409	1065			

Component Changes, Inspections, Service Bulletins, or Airworthiness Directives Accomplished

Item	Transaction No. Type	Item Name	Position	Part Number / Alternate Part Number	Mod Level	Part Serial	Removal Reason	InstalledPart Status TSN/TSO/TSR	Material Costs	Man Hours
5-15-07	1 2	INSPECTION DOCUMENT 07								
Comments:										

Trans. Type: 1 - Component, 2 - Inspection, 3 - SB, 4 - AD, - - Misc.

Removal Reasons: WO - Worn to Limits, SC - Scheduled, UN - Unscheduled, CO - Convenience, N - Other(note in comments)

Installed Part Status: N - New, R - Repaired/Rebuilt, S - Serviceable, O - Overhauled

Repair Facility SUBIC **Certified Repair Station Number** _____ **Work Order No.** S16059
Work Performed By ARIEL JASON M. DAYRIT **Certificate No.** 102495-AMT **Date** 18-Dec-2016
 I certify that the above stated maintenance and/or inspection was performed in accordance with the current regulations of the
 Federal Aviation Administration Other (Specify) CAAP and
 THE AIRCRAFT IDENTIFIED ABOVE IS PRESENTLY AIRWORTHY AND APPROVED FOR RETURN TO SERVICE.
Work Inspected By KRISTOFER ALLEN GABISON **Certificate No.** 110205-AMT **Date** 18-Dec-2016
 Pertinent details of this maintenance are on file at our facility under the above Work/Service Order Number as applicable.

Maintenance Log	
Book	Page



Maintenance Transaction Record



This Maintenance Report is To Be Used Solely For (Check One)

Airframe Entries
 Eng. Serial No. _____
 Prop. Serial No. _____

CAMP Systems International
 8200 E. 34TH STREET
 BUILDING 1600, SUITE 1607
 Wichita, KS 67226
 Phone: 316-462-2267/ Fax: 316-462-0791

Aircraft Identification and Status

A/C Serial #	A/C Unit #	A/C Registration #	Date	City ID	Total A/C Hours	Total A/C Landings	Total Engine Hrs	Total Engine Cycles	Total Prop Hrs			
208B-5098		RP-C1087	10-Dec-2016	RPLB	1046.2	1394	1046.2	1394	1046.2			

Component Changes, Inspections, Service Bulletins, or Airworthiness Directives Accomplished

Item	Transaction No.	Type	Item Name	Position	Part Number / Alternate Part Number	Mod Level	Part Serial	Removal Reason	InstalledPart Status	TSN/TSO/TSR	Material Costs	Man Hours
5-15-06	1	2	INSPECTION DOCUMENT 06									
Comments:												
614010	2	2	NO. 1 PROPELLER - INSPECT PROPELLER									
Comments:												
614010	3	2	NO. 1 PROPELLER - INSPECT PROPELLER									
Comments:												
725040	4	2	NO. 1 ENGINE - GENERAL VISUAL INSPECTION ENGINE EXHAUST DUCT FOR CRACKS									
Comments:												
760000	5	2	NO. 1 ENGINE - DOWNLOAD ECTM									
Comments:												

Trans. Type: 1 - Component, 2 - Inspection, 3 - SB, 4 - AD, -- Misc.

Removal Reasons: WO - Worn to Limits, SC - Scheduled, UN - Unscheduled, CO - Convenience, N - Other(note in comments)

Installed Part Status: N - New, R - Repaired/Rebuilt, S - Serviceable, O - Overhauled

Repair Facility	SUBIC	Certified Repair Station Number	Work Order No.	S16044
Work Performed By	ARIEL JASON M. DAYRIT		Certificate No.	102495-AMT
			Date	10-Dec-2016
I certify that the above stated maintenance and/or inspection was performed in accordance with the current regulations of the <input type="checkbox"/> Federal Aviation Administration <input checked="" type="checkbox"/> Other (Specify) CAAP and THE AIRCRAFT IDENTIFIED ABOVE IS PRESENTLY AIRWORTHY AND APPROVED FOR RETURN TO SERVICE.				
Work Inspected By	MIKE ANGELO MARTINEZ		Certificate No.	112468-AMT
			Date	10-Dec-2016
Pertinent details of this maintenance are on file at our facility under the above Work/Service Order Number as applicable.				

Maintenance Log	
Book	Page



Maintenance Transaction Record



This Maintenance Report is To Be Used Solely For (Check One)

Airframe Entries Eng. Serial No. PCE-VA0103 Prop. Serial No. BUA32866

CAMP Systems International
8200 E. 34TH STREET
BUILDING 1600, SUITE 1607
Wichita, KS 67226
Phone: 316-462-2267/ Fax: 316-462-0791

Aircraft Identification and Status

A/C Serial #	A/C Unit #	A/C Registration #	Date	City ID	Total A/C Hours	Total A/C Landings	Total Engine Hrs	Total Engine Cycles	Total Prop Hrs			
208B-5098		RP-C1087	26-Sep-2016	RPLL	1002.1	1302	1002.1	1302	1002.1			

Component Changes, Inspections, Service Bulletins, or Airworthiness Directives Accomplished

Item	Transaction No. Type	Item Name	Position	Part Number / Alternate Part Number	Mod Level	Part Serial	Removal Reason	InstalledPart Status TSN/TSO/TSR	Material Costs	Man Hours
051001	1 2	RENEWAL AIRWORTHINESS								
Comments: CERTIFICATE OF AIRWORTHINESS.										

Trans. Type: 1 - Component, 2 - Inspection, 3 - SB, 4 - AD, - - Misc.

Removal Reasons: WO - Worn to Limits, SC - Scheduled, UN - Unscheduled, CO - Convenience, N - Other(note in comments)

Installed Part Status: N - New, R - Repaired/Rebuilt, S - Serviceable, O - Overhauled

Repair Facility _____	Certified Repair Station Number _____	Work Order No. <u>160423</u>
Work Performed By <u>DAVE BANARES</u>	Certificate No. <u>114533-AMT</u>	Date <u>23-Sep-2016</u>
I certify that the above stated maintenance and/or inspection was performed in accordance with the current regulations of the <input type="checkbox"/> Federal Aviation Administration <input checked="" type="checkbox"/> Other (Specify) <u>CAAP</u> and		
THE AIRCRAFT IDENTIFIED ABOVE IS PRESENTLY AIRWORTHY AND APPROVED FOR RETURN TO SERVICE.		
Work Inspected By <u>NESTOR DERPO</u>	Certificate No. <u>119184-AMT</u>	Date <u>23-Sep-2016</u>
Pertinent details of this maintenance are on file at our facility under the above Work/Service Order Number as applicable.		

Maintenance Log	
Book	Page



Maintenance Transaction Record



This Maintenance Report is To Be Used Solely For (Check One)

Airframe Entries Eng. Serial No. PCE-VA0103 Prop. Serial No. BUA32866

CAMP Systems International
8200 E. 34TH STREET
BUILDING 1600, SUITE 1607
Wichita, KS 67226
Phone: 316-462-2267/ Fax: 316-462-0791

Aircraft Identification and Status

A/C Serial #	A/C Unit #	A/C Registration #	Date	City ID	Total A/C Hours	Total A/C Landings	Total Engine Hrs	Total Engine Cycles	Total Prop Hrs			
208B-5098		RP-C1087	23-Sep-2016	RPLL	1002.1	1302	1002.1	1302	1002.1			

Component Changes, Inspections, Service Bulletins, or Airworthiness Directives Accomplished

Item	Transaction No. Type	Item Name	Position	Part Number / Alternate Part Number	Mod Level	Part Serial	Removal Reason	InstalledPart Status TSN/TSO/TSR	Material Costs	Man Hours
2627563	1 2	CERTIFICATION OF AIRWORTHINESS				208B5098				
Comments: CERTIFICATE OF AIRWORTHINESS SURVEY NEXT DUE AT 23 SEPTEMBER,2017.										

Trans. Type: 1 - Component, 2 - Inspection, 3 - SB, 4 - AD, - - Misc.

Removal Reasons: WO - Worn to Limits, SC - Scheduled, UN - Unscheduled, CO - Convenience, N - Other(note in comments)

Installed Part Status: N - New, R - Repaired/Rebuilt, S - Serviceable, O - Overhauled

Repair Facility _____	Certified Repair Station Number _____	Work Order No. <u>160423</u>
Work Performed By <u>DAVE BANARES</u>	Certificate No. <u>114533-AMT</u>	Date <u>23-Sep-2016</u>
I certify that the above stated maintenance and/or inspection was performed in accordance with the current regulations of the <input type="checkbox"/> Federal Aviation Administration <input checked="" type="checkbox"/> Other (Specify) <u>CAAP</u> and		
THE AIRCRAFT IDENTIFIED ABOVE IS PRESENTLY AIRWORTHY AND APPROVED FOR RETURN TO SERVICE.		
Work Inspected By <u>NESTOR DERPO</u>	Certificate No. <u>119184-AMT</u>	Date <u>23-Sep-2016</u>
Pertinent details of this maintenance are on file at our facility under the above Work/Service Order Number as applicable.		

Maintenance Log	
Book	Page



Maintenance Transaction Record



This Maintenance Report is To Be Used Solely For (Check One)

Airframe Entries Eng. Serial No. PCE-VA0103 Prop. Serial No. BUA32866

CAMP Systems International
8200 E. 34TH STREET
BUILDING 1600, SUITE 1607
Wichita, KS 67226
Phone: 316-462-2267/ Fax: 316-462-0791

Aircraft Identification and Status

A/C Serial #	A/C Unit #	A/C Registration #	Date	City ID	Total A/C Hours	Total A/C Landings	Total Engine Hrs	Total Engine Cycles	Total Prop Hrs			
208B-5098		RP-C1087	18-Sep-2016	RPLL	999.5	1299	999.5	1299	999.5			

Component Changes, Inspections, Service Bulletins, or Airworthiness Directives Accomplished

Item	Transaction No.	Type	Item Name	Position	Part Number / Alternate Part Number	Mod Level	Part Serial	Removal Reason	Installed Part Status	TSN/TSO/TSR	Material Costs	Man Hours
051265	1	2	INSPECT 50 HR INSP-FLOATS									
Comments: CARRIED OUT INSP IAW WIPAIRE FLOATS AMM 8750. SATISFACTORY												

Trans. Type: 1 - Component, 2 - Inspection, 3 - SB, 4 - AD, - - Misc.

Removal Reasons: WO - Worn to Limits, SC - Scheduled, UN - Unscheduled, CO - Convenience, N - Other(note in comments)

Installed Part Status: N - New, R - Repaired/Rebuilt, S - Serviceable, O - Overhauled

Repair Facility _____	Certified Repair Station Number _____	Work Order No. <u>160413</u>
Work Performed By <u>DAVE BANARES</u>	Certificate No. <u>114533-AMT</u>	Date <u>19-Sep-2016</u>
I certify that the above stated maintenance and/or inspection was performed in accordance with the current regulations of the <input type="checkbox"/> Federal Aviation Administration <input checked="" type="checkbox"/> Other (Specify) <u>CAAP</u> and _____		
THE AIRCRAFT IDENTIFIED ABOVE IS PRESENTLY AIRWORTHY AND APPROVED FOR RETURN TO SERVICE.		
Work Inspected By <u>NESTOR DERPO</u>	Certificate No. <u>119184-AMT</u>	Date <u>19-Sep-2016</u>
Pertinent details of this maintenance are on file at our facility under the above Work/Service Order Number as applicable.		

Maintenance Log	
Book	Page



Maintenance Transaction Record



This Maintenance Report is To Be Used Solely For (Check One)

Airframe Entries Eng. Serial No. PCE-VA0103 Prop. Serial No. BUA32866

CAMP Systems International
8200 E. 34TH STREET
BUILDING 1600, SUITE 1607
Wichita, KS 67226
Phone: 316-462-2267/ Fax: 316-462-0791

Aircraft Identification and Status

A/C Serial #	A/C Unit #	A/C Registration #	Date	City ID	Total A/C Hours	Total A/C Landings	Total Engine Hrs	Total Engine Cycles	Total Prop Hrs			
208B-5098		RP-C1087	18-Sep-2016	RPLL	999.5	1299	999.5	1299	999.5			

Component Changes, Inspections, Service Bulletins, or Airworthiness Directives Accomplished

Item	Transaction No.	Type	Item Name	Position	Part Number / Alternate Part Number	Mod Level	Part Serial	Removal Reason	Installed Part Status	TSN/TSO/TSR	Material Costs	Man Hours
051260	1	2	INSPECT 25 HR INSP-FLOATS									
Comments: CARRIED OUT INSP IAW WIPAIRE FLOATS AMM 8750. SATISFACTORY												

Trans. Type: 1 - Component, 2 - Inspection, 3 - SB, 4 - AD, - - Misc.

Removal Reasons: WO - Worn to Limits, SC - Scheduled, UN - Unscheduled, CO - Convenience, N - Other(note in comments)

Installed Part Status: N - New, R - Repaired/Rebuilt, S - Serviceable, O - Overhauled

Repair Facility _____	Certified Repair Station Number _____	Work Order No. <u>160413</u>
Work Performed By <u>DAVE BANARES</u>	Certificate No. <u>114533-AMT</u>	Date <u>14-Sep-2016</u>
I certify that the above stated maintenance and/or inspection was performed in accordance with the current regulations of the <input type="checkbox"/> Federal Aviation Administration <input checked="" type="checkbox"/> Other (Specify) <u>CAAP</u> and _____		
THE AIRCRAFT IDENTIFIED ABOVE IS PRESENTLY AIRWORTHY AND APPROVED FOR RETURN TO SERVICE.		
Work Inspected By <u>NESTOR DERPO</u>	Certificate No. <u>119184-AMT</u>	Date <u>14-Sep-2016</u>
Pertinent details of this maintenance are on file at our facility under the above Work/Service Order Number as applicable.		

Maintenance Log	
Book	Page



Maintenance Transaction Record



This Maintenance Report is To Be Used Solely For (Check One)

Airframe Entries Eng. Serial No. PCE-VA0103 Prop. Serial No. BUA32866

CAMP Systems International
8200 E. 34TH STREET
BUILDING 1600, SUITE 1607
Wichita, KS 67226
Phone: 316-462-2267/ Fax: 316-462-0791

Aircraft Identification and Status

A/C Serial #	A/C Unit #	A/C Registration #	Date	City ID	Total A/C Hours	Total A/C Landings	Total Engine Hrs	Total Engine Cycles	Total Prop Hrs			
208B-5098		RP-C1087	18-Sep-2016	RPLL	999.5	1299	999.5	1299	999.5			

Component Changes, Inspections, Service Bulletins, or Airworthiness Directives Accomplished

Item	Transaction No.	Type	Item Name	Position	Part Number / Alternate Part Number	Mod Level	Part Serial	Removal Reason	Installed Part Status	TSN/TSO/TSR	Material Costs	Man Hours
051270	1	2	INSPECT 100 HR INSP-FLOATS									
Comments: CARRIED OUT INSP IAW WIPAIRE FLOATS AMM 8750. SATISFACTORY												

Trans. Type: 1 - Component, 2 - Inspection, 3 - SB, 4 - AD, - - Misc.

Removal Reasons: WO - Worn to Limits, SC - Scheduled, UN - Unscheduled, CO - Convenience, N - Other(note in comments)

Installed Part Status: N - New, R - Repaired/Rebuilt, S - Serviceable, O - Overhauled

Repair Facility _____	Certified Repair Station Number _____	Work Order No. <u>160413</u>
Work Performed By <u>KRISTOPHER ALLEN GABISON</u>	Certificate No. <u>110205-AMT</u>	Date <u>14-Sep-2016</u>
I certify that the above stated maintenance and/or inspection was performed in accordance with the current regulations of the <input type="checkbox"/> Federal Aviation Administration <input checked="" type="checkbox"/> Other (Specify) <u>CAAP</u> and _____		
THE AIRCRAFT IDENTIFIED ABOVE IS PRESENTLY AIRWORTHY AND APPROVED FOR RETURN TO SERVICE.		
Work Inspected By <u>NESTOR DERPO</u>	Certificate No. <u>119184-AMT</u>	Date <u>14-Sep-2016</u>
Pertinent details of this maintenance are on file at our facility under the above Work/Service Order Number as applicable.		

Maintenance Log	
Book	Page



Maintenance Transaction Record



This Maintenance Report is To Be Used Solely For (Check One)

Airframe Entries Eng. Serial No. PCE-VA0103 Prop. Serial No. BUA32866

CAMP Systems International
8200 E. 34TH STREET
BUILDING 1600, SUITE 1607
Wichita, KS 67226
Phone: 316-462-2267/ Fax: 316-462-0791

Aircraft Identification and Status

A/C Serial #	A/C Unit #	A/C Registration #	Date	City ID	Total A/C Hours	Total A/C Landings	Total Engine Hrs	Total Engine Cycles	Total Prop Hrs			
208B-5098		RP-C1087	18-Sep-2016	RPLL	999.5	1299	999.5	1299	999.5			

Component Changes, Inspections, Service Bulletins, or Airworthiness Directives Accomplished

Item	Transaction No. Type	Item Name	Position	Part Number / Alternate Part Number	Mod Level	Part Serial	Removal Reason	Installed Part Status TSN/TSO/TSR	Material Costs	Man Hours
051275	1 2	INSPECT 200 HR INSP-FLOATS								
Comments: CARRIED OUT INSP IAW WIPAIRE FLOATS AMM 8750. SATISFACTORY										

Trans. Type: 1 - Component, 2 - Inspection, 3 - SB, 4 - AD, - - Misc.

Removal Reasons: WO - Worn to Limits, SC - Scheduled, UN - Unscheduled, CO - Convenience, N - Other(note in comments)

Installed Part Status: N - New, R - Repaired/Rebuilt, S - Serviceable, O - Overhauled

Repair Facility _____	Certified Repair Station Number _____	Work Order No. <u>160413</u>
Work Performed By <u>KRISTOPHER ALLEN GABISON</u>	Certificate No. <u>110205-AMT</u>	Date <u>14-Sep-2016</u>
I certify that the above stated maintenance and/or inspection was performed in accordance with the current regulations of the <input type="checkbox"/> Federal Aviation Administration <input checked="" type="checkbox"/> Other (Specify) <u>CAAP</u> and _____		
THE AIRCRAFT IDENTIFIED ABOVE IS PRESENTLY AIRWORTHY AND APPROVED FOR RETURN TO SERVICE.		
Work Inspected By <u>NESTOR DERPO</u>	Certificate No. <u>119184-AMT</u>	Date <u>14-Sep-2016</u>
Pertinent details of this maintenance are on file at our facility under the above Work/Service Order Number as applicable.		

Maintenance Log	
Book	Page



Maintenance Transaction Record



This Maintenance Report is To Be Used Solely For (Check One)

Airframe Entries Eng. Serial No. PCE-VA0103 Prop. Serial No. BUA32866

CAMP Systems International
8200 E. 34TH STREET
BUILDING 1600, SUITE 1607
Wichita, KS 67226
Phone: 316-462-2267/ Fax: 316-462-0791

Aircraft Identification and Status

A/C Serial #	A/C Unit #	A/C Registration #	Date	City ID	Total A/C Hours	Total A/C Landings	Total Engine Hrs	Total Engine Cycles	Total Prop Hrs			
208B-5098		RP-C1087	06-Sep-2016	RPLL	985.4	1283	985.4	1283	985.4			

Component Changes, Inspections, Service Bulletins, or Airworthiness Directives Accomplished

Item	Transaction No. Type	Item Name	Position	Part Number / Alternate Part Number	Mod Level	Part Serial	Removal Reason	Installed Part Status TSN/TSO/TSR	Material Costs	Man Hours
5-15-22	1 2	INSPECTION DOCUMENT 22								
Comments: CARRIED OUT INSP IAW C208B MAINTENANCE MANUAL TASK 34-50-720. SATISFACTORY NEXT DUE: 01 SEPTEMBER 2017 NOTE: C/W HAWKER PACIFIC										

Trans. Type: 1 - Component, 2 - Inspection, 3 - SB, 4 - AD, - - Misc.

Removal Reasons: WO - Worn to Limits, SC - Scheduled, UN - Unscheduled, CO - Convenience, N - Other(note in comments)

Installed Part Status: N - New, R - Repaired/Rebuilt, S - Serviceable, O - Overhauled

Repair Facility _____	Certified Repair Station Number _____	Work Order No. <u>160396</u>
Work Performed By <u>DAVE BANARES</u>	Certificate No. <u>114533-AMT</u>	Date <u>06-Sep-2016</u>
I certify that the above stated maintenance and/or inspection was performed in accordance with the current regulations of the <input type="checkbox"/> Federal Aviation Administration <input checked="" type="checkbox"/> Other (Specify) <u>CAAP</u> and _____		
THE AIRCRAFT IDENTIFIED ABOVE IS PRESENTLY AIRWORTHY AND APPROVED FOR RETURN TO SERVICE.		
Work Inspected By <u>NESTOR DERPO</u>	Certificate No. <u>119184-AMT</u>	Date <u>06-Sep-2016</u>
Pertinent details of this maintenance are on file at our facility under the above Work/Service Order Number as applicable.		

Maintenance Log	
Book	Page



Maintenance Transaction Record



This Maintenance Report is To Be Used Solely For (Check One)

Airframe Entries Eng. Serial No. PCE-VA0103 Prop. Serial No. BUA32866

CAMP Systems International
8200 E. 34TH STREET
BUILDING 1600, SUITE 1607
Wichita, KS 67226
Phone: 316-462-2267/ Fax: 316-462-0791

Aircraft Identification and Status

A/C Serial #	A/C Unit #	A/C Registration #	Date	City ID	Total A/C Hours	Total A/C Landings	Total Engine Hrs	Total Engine Cycles	Total Prop Hrs			
208B-5098		RP-C1087	06-Sep-2016	RPLL	977.7	1270	977.7	1270	977.7			

Component Changes, Inspections, Service Bulletins, or Airworthiness Directives Accomplished

Item	Transaction No.	Type	Item Name	Position	Part Number / Alternate Part Number	Mod Level	Part Serial	Removal Reason	Installed Part Status	TSN/TSO/TSR	Material Costs	Man Hours
5-15-20	1	2	INSPECTION DOCUMENT 20									
Comments: CARRIED OUT INSP IAW C208B MAINTENANCE MANUAL. SATISFACTORY												

Trans. Type: 1 - Component, 2 - Inspection, 3 - SB, 4 - AD, - - Misc.

Removal Reasons: WO - Worn to Limits, SC - Scheduled, UN - Unscheduled, CO - Convenience, N - Other(note in comments)

Installed Part Status: N - New, R - Repaired/Rebuilt, S - Serviceable, O - Overhauled

Repair Facility _____ **Certified Repair Station Number** _____ **Work Order No.** 160347
Work Performed By HAWKER PACIFIC ASIA PTE LTD. **Certificate No.** _____ **Date** 26-Aug-2016
 I certify that the above stated maintenance and/or inspection was performed in accordance with the current regulations of the
 Federal Aviation Administration Other (Specify) CAAP and _____
 THE AIRCRAFT IDENTIFIED ABOVE IS PRESENTLY AIRWORTHY AND APPROVED FOR RETURN TO SERVICE.
Work Inspected By NESTOR DERPO **Certificate No.** 119184-AMT **Date** 26-Aug-2016
 Pertinent details of this maintenance are on file at our facility under the above Work/Service Order Number as applicable.

Maintenance Log	
Book	Page



Maintenance Transaction Record



This Maintenance Report is To Be Used Solely For (Check One)

Airframe Entries Eng. Serial No. PCE-VA0103 Prop. Serial No. BUA32866

CAMP Systems International
8200 E. 34TH STREET
BUILDING 1600, SUITE 1607
Wichita, KS 67226
Phone: 316-462-2267/ Fax: 316-462-0791

Aircraft Identification and Status

A/C Serial #	A/C Unit #	A/C Registration #	Date	City ID	Total A/C Hours	Total A/C Landings	Total Engine Hrs	Total Engine Cycles	Total Prop Hrs			
208B-5098		RP-C1087	11-Sep-2016	RPLL	991.7	1292	991.7	1292	991.7			

Component Changes, Inspections, Service Bulletins, or Airworthiness Directives Accomplished

Item	Transaction No. Type	Item Name	Position	Part Number / Alternate Part Number	Mod Level	Part Serial	Removal Reason	Installed Part Status TSN/TSO/TSR	Material Costs	Man Hours
053417	1 2	UPDATE NAV DATABASE								
Comments: PERFORMED NAVIGATION DATABASE UPDATE IAW FLY GARMIN. SATISFACTORY. CYCLE: 1610 EFFECTIVE: 15-SEP-2016 EXPIRE: 13-OCT-2016										

Trans. Type: 1 - Component, 2 - Inspection, 3 - SB, 4 - AD, - - Misc.

Removal Reasons: WO - Worn to Limits, SC - Scheduled, UN - Unscheduled, CO - Convenience, N - Other(note in comments)

Installed Part Status: N - New, R - Repaired/Rebuilt, S - Serviceable, O - Overhauled

Repair Facility _____	Certified Repair Station Number _____	Work Order No. <u>160402</u>
Work Performed By <u>LOUIE JAY ABOG</u>	Certificate No. <u>121069-AMS/AMT</u>	Date <u>11-Sep-2016</u>
I certify that the above stated maintenance and/or inspection was performed in accordance with the current regulations of the <input type="checkbox"/> Federal Aviation Administration <input checked="" type="checkbox"/> Other (Specify) <u>CAAP</u> and		
THE AIRCRAFT IDENTIFIED ABOVE IS PRESENTLY AIRWORTHY AND APPROVED FOR RETURN TO SERVICE.		
Work Inspected By <u>DAVE H.BANARES</u>	Certificate No. <u>114533-AMT</u>	Date <u>11-Sep-2016</u>
Pertinent details of this maintenance are on file at our facility under the above Work/Service Order Number as applicable.		

Maintenance Log	
Book	Page



Maintenance Transaction Record



This Maintenance Report is To Be Used Solely For (Check One)

Airframe Entries Eng. Serial No. PCE-VA0103 Prop. Serial No. BUA32866

CAMP Systems International
8200 E. 34TH STREET
BUILDING 1600, SUITE 1607
Wichita, KS 67226
Phone: 316-462-2267/ Fax: 316-462-0791

Aircraft Identification and Status

Table with columns: A/C Serial #, A/C Unit #, A/C Registration #, Date, City ID, Total A/C Hours, Total A/C Landings, Total Engine Hrs, Total Engine Cycles, Total Prop Hrs. Row 1: 208B-5098, RP-C1087, 02-Sep-2016, RPLL, 985.4, 1283, 985.4, 1283, 985.4

Component Changes, Inspections, Service Bulletins, or Airworthiness Directives Accomplished

Table with columns: Item, Transaction No. Type, Item Name, Position, Part Number / Alternate Part Number, Mod Level, Part Serial, Removal Reason, Installed Part Status TSN/TSO/TSR, Material Costs, Man Hours. Row 1: CAB-27-03, 1 3, FLIGHT CONTROLS - INSPECTION OF AILERON CABLE INTERFERENCE, SERVICE BULLETIN MOC: COMPLIED WITH Comments: C/OUT FLIGHT CONTROLS - INSPECTION OF AILERON CABLE INTERFERENCE IAW SB CAB 27-03 , SATISFACTORY

Trans. Type: 1 - Component, 2 - Inspection, 3 - SB, 4 - AD, - - Misc.

Removal Reasons: WO - Worn to Limits, SC - Scheduled, UN - Unscheduled, CO - Convenience, N - Other(note in comments)

Installed Part Status: N - New, R - Repaired/Rebuilt, S - Serviceable, O - Overhauled

Repair Facility, Certified Repair Station Number, Work Order No., Work Performed By DAVE BANARES, Certificate No. 114533-AMT, Date 02-Sep-2016. I certify that the above stated maintenance and/or inspection was performed in accordance with the current regulations of the Federal Aviation Administration and THE AIRCRAFT IDENTIFIED ABOVE IS PRESENTLY AIRWORTHY AND APPROVED FOR RETURN TO SERVICE. Work Inspected By NESTOR L DERPO, Certificate No. 119184-AMT, Date 02-Sep-2016. Pertinent details of this maintenance are on file at our facility under the above Work/Service Order Number as applicable.

Maintenance Log table with columns: Book, Page



Maintenance Transaction Record



This Maintenance Report is To Be Used Solely For (Check One)

Airframe Entries Eng. Serial No. PCE-VA0103 Prop. Serial No. BUA32866

CAMP Systems International
8200 E. 34TH STREET
BUILDING 1600, SUITE 1607
Wichita, KS 67226
Phone: 316-462-2267/ Fax: 316-462-0791

Aircraft Identification and Status

A/C Serial #	A/C Unit #	A/C Registration #	Date	City ID	Total A/C Hours	Total A/C Landings	Total Engine Hrs	Total Engine Cycles	Total Prop Hrs			
208B-5098		RP-C1087	02-Sep-2016	RPLL	907.1	1158	907.1	1158	907.1			

Component Changes, Inspections, Service Bulletins, or Airworthiness Directives Accomplished

Item	Transaction No.	Type	Item Name	Position	Part Number / Alternate Part Number	Mod Level	Part Serial	Removal Reason	Installed Part Status	TSN/TSO/TSR	Material Costs	Man Hours
340035	1	1	NO. 1 TRANSPONDER	NO. 1	011-00779-10	S3100-474	89128030	CO	S			
Comments: SWAP TRANSPONDER FROM 1087 TO 1780 IAW C208 MAINTENANCE MANUAL (REV 30) CH 34-54-20 (REV 20). SATISFACTORY												
340035	2	1	NO. 2 TRANSPONDER	NO. 2	011-00779-10	S3100-474	89127200	CO	S			
Comments: SWAP TRANSPONDER FROM 1087 TO 1780 IAW C208 MAINTENANCE MANUAL (REV 30) CH 34-54-20 (REV 20). SATISFACTORY												

Trans. Type: 1 - Component, 2 - Inspection, 3 - SB, 4 - AD, - - Misc.

Removal Reasons: WO - Worn to Limits, SC - Scheduled, UN - Unscheduled, CO - Convenience, N - Other(note in comments)

Installed Part Status: N - New, R - Repaired/Rebuilt, S - Serviceable, O - Overhauled

Repair Facility _____	Certified Repair Station Number _____	Work Order No. <u>160259</u>
Work Performed By <u>ROMEO LERIOS</u>	Certificate No. <u>112167-AMS/AMT</u>	Date <u>20-Jun-2016</u>
I certify that the above stated maintenance and/or inspection was performed in accordance with the current regulations of the <input type="checkbox"/> Federal Aviation Administration <input checked="" type="checkbox"/> Other (Specify) <u>CAAP</u> and		
THE AIRCRAFT IDENTIFIED ABOVE IS PRESENTLY AIRWORTHY AND APPROVED FOR RETURN TO SERVICE.		
Work Inspected By <u>NESTOR DERPO</u>	Certificate No. <u>119184-AMT</u>	Date <u>20-Jun-2016</u>
Pertinent details of this maintenance are on file at our facility under the above Work/Service Order Number as applicable.		

Maintenance Log	
Book	Page



Maintenance Transaction Record



This Maintenance Report is To Be Used Solely For (Check One)

Airframe Entries Eng. Serial No. A0103 Prop. Serial No. BUA32866

CAMP Systems International
8200 E. 34TH STREET
BUILDING 1600, SUITE 1607
Wichita, KS 67226
Phone: 316-462-2267/ Fax: 316-462-0791

Aircraft Identification and Status

A/C Serial #	A/C Unit #	A/C Registration #	Date	City ID	Total A/C Hours	Total A/C Landings	Total Engine Hrs	Total Engine Cycles	Total Prop Hrs			
208B-5098		RP-C1087	24-Aug-2016	RPLL	974.7	1263	974.7	1263	974.7			

Component Changes, Inspections, Service Bulletins, or Airworthiness Directives Accomplished

Item	Transaction No. Type	Item Name	Position	Part Number / Alternate Part Number	Mod Level	Part Serial	Removal Reason	InstalledPart Status TSN/TSO/TSR	Material Costs	Man Hours
051260	1 2	INSPECT 25 HR INSP-FLOATS								
Comments: CARRIED OUT INSP. IAW 8750 WIPAIRE FLOAT MANUAL. SATISFACTORY										

Trans. Type: 1 - Component, 2 - Inspection, 3 - SB, 4 - AD, - - Misc.

Removal Reasons: WO - Worn to Limits, SC - Scheduled, UN - Unscheduled, CO - Convenience, N - Other(note in comments)

Installed Part Status: N - New, R - Repaired/Rebuilt, S - Serviceable, O - Overhauled

Repair Facility _____	Certified Repair Station Number _____	Work Order No. <u>160370</u>
Work Performed By <u>ARISTEO ALCALA</u>	Certificate No. <u>115162-AMT</u>	Date <u>24-Aug-2016</u>
I certify that the above stated maintenance and/or inspection was performed in accordance with the current regulations of the <input type="checkbox"/> Federal Aviation Administration <input checked="" type="checkbox"/> Other (Specify) <u>CAAP</u> and _____		
Work Inspected By <u>NESTOR DERPO</u>	Certificate No. <u>119184-AMT</u>	Date <u>24-Aug-2016</u>
Pertinent details of this maintenance are on file at our facility under the above Work/Service Order Number as applicable.		

Maintenance Log	
Book	Page



Maintenance Transaction Record



This Maintenance Report is To Be Used Solely For (Check One)

Airframe Entries Eng. Serial No. PCE-VA0103 Prop. Serial No. BUA32866

CAMP Systems International
8200 E. 34TH STREET
BUILDING 1600, SUITE 1607
Wichita, KS 67226
Phone: 316-462-2267/ Fax: 316-462-0791

Aircraft Identification and Status

A/C Serial #	A/C Unit #	A/C Registration #	Date	City ID	Total A/C Hours	Total A/C Landings	Total Engine Hrs	Total Engine Cycles	Total Prop Hrs			
208B-5098		RP-C1087	22-Aug-2016	RPLL	967.1	1255	967.1	1255	967.1			

Component Changes, Inspections, Service Bulletins, or Airworthiness Directives Accomplished

Item	Transaction No.	Type	Item Name	Position	Part Number / Alternate Part Number	Mod Level	Part Serial	Removal Reason	Installed Part Status	TSN/TSO/TSR	Material Costs	Man Hours
053417	1	2	UPDATE NAV DATABASE									
Comments: PERFORMED NAVIGATION DATABASE UPDARE IAW FLY GARMIN.												

Trans. Type: 1 - Component, 2 - Inspection, 3 - SB, 4 - AD, - - Misc.

Removal Reasons: WO - Worn to Limits, SC - Scheduled, UN - Unscheduled, CO - Convenience, N - Other(note in comments)

Installed Part Status: N - New, R - Repaired/Rebuilt, S - Serviceable, O - Overhauled

Repair Facility _____	Certified Repair Station Number _____	Work Order No. <u>160360</u>
Work Performed By <u>LOUIE JAY ABOG</u>	Certificate No. <u>121069-AMS/AMT</u>	Date <u>17-Aug-2016</u>
I certify that the above stated maintenance and/or inspection was performed in accordance with the current regulations of the <input type="checkbox"/> Federal Aviation Administration <input checked="" type="checkbox"/> Other (Specify) <u>CAAP</u> and		
THE AIRCRAFT IDENTIFIED ABOVE IS PRESENTLY AIRWORTHY AND APPROVED FOR RETURN TO SERVICE.		
Work Inspected By <u>NESTOR DERPO</u>	Certificate No. <u>119184-AMT</u>	Date <u>17-Aug-2016</u>
Pertinent details of this maintenance are on file at our facility under the above Work/Service Order Number as applicable.		

Maintenance Log	
Book	Page



Maintenance Transaction Record



This Maintenance Report is To Be Used Solely For (Check One)

Airframe Entries Eng. Serial No. PCE-VA0103 Prop. Serial No. BUA32866

CAMP Systems International
8200 E. 34TH STREET
BUILDING 1600, SUITE 1607
Wichita, KS 67226
Phone: 316-462-2267/ Fax: 316-462-0791

Aircraft Identification and Status

A/C Serial #	A/C Unit #	A/C Registration #	Date	City ID	Total A/C Hours	Total A/C Landings	Total Engine Hrs	Total Engine Cycles	Total Prop Hrs			
208B-5098		RP-C1087	18-Aug-2016	RPLL	950	1222	950	1222	950			

Component Changes, Inspections, Service Bulletins, or Airworthiness Directives Accomplished

Item	Transaction No.	Type	Item Name	Position	Part Number / Alternate Part Number	Mod Level	Part Serial	Removal Reason	Installed Part Status	TSN/TSO/TSR	Material Costs	Man Hours
051260	1	2	INSPECT 25 HR INSP-FLOATS									
Comments: CARRIED OUT INSP IAW WIPAIRE FLOATS SERVICE MANUAL 8750. SATISFACTORY												

Trans. Type: 1 - Component, 2 - Inspection, 3 - SB, 4 - AD, - - Misc.

Removal Reasons: WO - Worn to Limits, SC - Scheduled, UN - Unscheduled, CO - Convenience, N - Other(note in comments)

Installed Part Status: N - New, R - Repaired/Rebuilt, S - Serviceable, O - Overhauled

Repair Facility _____ **Certified Repair Station Number** _____ **Work Order No.** 160328
Work Performed By MIKE ANGELO MARTINES **Certificate No.** 112468-AMT **Date** 25-Jul-2016
 I certify that the above stated maintenance and/or inspection was performed in accordance with the current regulations of the
 Federal Aviation Administration Other (Specify) CAAP and
 THE AIRCRAFT IDENTIFIED ABOVE IS PRESENTLY AIRWORTHY AND APPROVED FOR RETURN TO SERVICE.
Work Inspected By NESTOR DERPO **Certificate No.** 119184-AMT **Date** 25-Jul-2016
 Pertinent details of this maintenance are on file at our facility under the above Work/Service Order Number as applicable.

Maintenance Log	
Book	Page



Maintenance Transaction Record



This Maintenance Report is To Be Used Solely For (Check One)

Airframe Entries Eng. Serial No. PCE-VA0103 Prop. Serial No. BUA32866

CAMP Systems International
8200 E. 34TH STREET
BUILDING 1600, SUITE 1607
Wichita, KS 67226
Phone: 316-462-2267/ Fax: 316-462-0791

Aircraft Identification and Status

A/C Serial #	A/C Unit #	A/C Registration #	Date	City ID	Total A/C Hours	Total A/C Landings	Total Engine Hrs	Total Engine Cycles	Total Prop Hrs			
208B-5098		RP-C1087	18-Aug-2016	RPLL	804.1	1019	804.1	1019	804.1			

Component Changes, Inspections, Service Bulletins, or Airworthiness Directives Accomplished

Item	Transaction No. Type	Item Name	Position	Part Number / Alternate Part Number	Mod Level	Part Serial	Removal Reason	Installed Part Status TSN/TSO/TSR	Material Costs	Man Hours
051275	1 2	INSPECT 200 HR INSP-FLOATS								
Comments: CARRIED OUT INSP IAW WIPAIRE FLOATS MANUAL 8750. SATISFACTORY										

Trans. Type: 1 - Component, 2 - Inspection, 3 - SB, 4 - AD, - - Misc.

Removal Reasons: WO - Worn to Limits, SC - Scheduled, UN - Unscheduled, CO - Convenience, N - Other(note in comments)

Installed Part Status: N - New, R - Repaired/Rebuilt, S - Serviceable, O - Overhauled

Repair Facility _____ **Certified Repair Station Number** _____ **Work Order No.** 160288
Work Performed By DAVE BANARES **Certificate No.** 114533-AMT **Date** 14-Feb-2016
 I certify that the above stated maintenance and/or inspection was performed in accordance with the current regulations of the
 Federal Aviation Administration Other (Specify) CAAP and
 THE AIRCRAFT IDENTIFIED ABOVE IS PRESENTLY AIRWORTHY AND APPROVED FOR RETURN TO SERVICE.
Work Inspected By NESTOR DERPO **Certificate No.** 119184-AMT **Date** 14-Feb-2016
 Pertinent details of this maintenance are on file at our facility under the above Work/Service Order Number as applicable.

Maintenance Log	
Book	Page



Maintenance Transaction Record



This Maintenance Report is To Be Used Solely For (Check One)

Airframe Entries Eng. Serial No. PCE-VA010 Prop. Serial No. BUA32866

CAMP Systems International
8200 E. 34TH STREET
BUILDING 1600, SUITE 1607
Wichita, KS 67226
Phone: 316-462-2267/ Fax: 316-462-0791

Aircraft Identification and Status

A/C Serial #	A/C Unit #	A/C Registration #	Date	City ID	Total A/C Hours	Total A/C Landings	Total Engine Hrs	Total Engine Cycles	Total Prop Hrs			
208B-5098		RP-C1087	18-Aug-2016	RPLL	804.1	1019	804.1	1019	804.1			

Component Changes, Inspections, Service Bulletins, or Airworthiness Directives Accomplished

Item	Transaction No.	Type	Item Name	Position	Part Number / Alternate Part Number	Mod Level	Part Serial	Removal Reason	Installed Part Status	TSN/TSO/TSR	Material Costs	Man Hours
725040	1	2	NO. 1 ENGINE - GENERAL VISUAL INSPECTION ENGINE EXHAUST DUCT FOR CRACKS Comments: CARRIED OUT INSP IAW C208B AMM 78-10-00. SATISFACTORY									

Trans. Type: 1 - Component, 2 - Inspection, 3 - SB, 4 - AD, - - Misc.

Removal Reasons: WO - Worn to Limits, SC - Scheduled, UN - Unscheduled, CO - Convenience, N - Other (note in comments)

Installed Part Status: N - New, R - Repaired/Rebuilt, S - Serviceable, O - Overhauled

Repair Facility _____ **Certified Repair Station Number** _____ **Work Order No.** 160050
Work Performed By DAVE BANARES **Certificate No.** 114533-AMT **Date** 14-Feb-2016
 I certify that the above stated maintenance and/or inspection was performed in accordance with the current regulations of the
 Federal Aviation Administration Other (Specify) CAAP and
 THE AIRCRAFT IDENTIFIED ABOVE IS PRESENTLY AIRWORTHY AND APPROVED FOR RETURN TO SERVICE.
Work Inspected By NESTOR DERPO **Certificate No.** 119184-AMT **Date** 14-Feb-2016
 Pertinent details of this maintenance are on file at our facility under the above Work/Service Order Number as applicable.

Maintenance Log	
Book	Page



Maintenance Transaction Record



This Maintenance Report is To Be Used Solely For (Check One)

Airframe Entries Eng. Serial No. PCE-VA0103 Prop. Serial No. BUA32866

CAMP Systems International
8200 E. 34TH STREET
BUILDING 1600, SUITE 1607
Wichita, KS 67226
Phone: 316-462-2267/ Fax: 316-462-0791

Aircraft Identification and Status

A/C Serial #	A/C Unit #	A/C Registration #	Date	City ID	Total A/C Hours	Total A/C Landings	Total Engine Hrs	Total Engine Cycles	Total Prop Hrs			
208B-5098		RP-C1087	17-Aug-2016	RPLL	948.2	1222	948.2	1222	948.2			

Component Changes, Inspections, Service Bulletins, or Airworthiness Directives Accomplished

Item	Transaction No.	Type	Item Name	Position	Part Number / Alternate Part Number	Mod Level	Part Serial	Removal Reason	Installed Part Status	TSN/TSO/TSR	Material Costs	Man Hours
051260	1	2	INSPECT 25 HR INSP-FLOATS									
Comments: CARRIED OUT INSP IAW WIPAIRE FLOATS MANUAL 8750 - 25 HRS INSP FLOATS. SATISFACTORY												

Trans. Type: 1 - Component, 2 - Inspection, 3 - SB, 4 - AD, - - Misc.

Removal Reasons: WO - Worn to Limits, SC - Scheduled, UN - Unscheduled, CO - Convenience, N - Other(note in comments)

Installed Part Status: N - New, R - Repaired/Rebuilt, S - Serviceable, O - Overhauled

Repair Facility _____	Certified Repair Station Number _____	Work Order No. <u>160328</u>
Work Performed By <u>DAVE BANARES</u>	Certificate No. <u>114533-AMT</u>	Date <u>25-Jul-2016</u>
I certify that the above stated maintenance and/or inspection was performed in accordance with the current regulations of the		
<input type="checkbox"/> Federal Aviation Administration <input checked="" type="checkbox"/> Other (Specify) <u>CAAP</u> and		
THE AIRCRAFT IDENTIFIED ABOVE IS PRESENTLY AIRWORTHY AND APPROVED FOR RETURN TO SERVICE.		
Work Inspected By <u>NESTOR DERPO</u>	Certificate No. <u>119184-AMT</u>	Date <u>25-Jul-2016</u>
Pertinent details of this maintenance are on file at our facility under the above Work/Service Order Number as applicable.		

Maintenance Log	
Book	Page



Maintenance Transaction Record



This Maintenance Report is To Be Used Solely For (Check One)

Airframe Entries Eng. Serial No. PCE-VA0103 Prop. Serial No. BUA32866

CAMP Systems International
8200 E. 34TH STREET
BUILDING 1600, SUITE 1607
Wichita, KS 67226
Phone: 316-462-2267/ Fax: 316-462-0791

Aircraft Identification and Status

A/C Serial #	A/C Unit #	A/C Registration #	Date	City ID	Total A/C Hours	Total A/C Landings	Total Engine Hrs	Total Engine Cycles	Total Prop Hrs			
208B-5098		RP-C1087	17-Aug-2016	RPLL	786.2	995	786.2	995	786.2			

Component Changes, Inspections, Service Bulletins, or Airworthiness Directives Accomplished

Item	Transaction No.	Type	Item Name	Position	Part Number / Alternate Part Number	Mod Level	Part Serial	Removal Reason	Installed Part Status	TSN/TSO/TSR	Material Costs	Man Hours
051275	1	2	INSPECT 200 HR INSP-FLOATS									
Comments: CARRIED OUT INSP IAW WIPAIRE FLOATS MANUAL 8750. SATISFACTORY												

Trans. Type: 1 - Component, 2 - Inspection, 3 - SB, 4 - AD, - - Misc.

Removal Reasons: WO - Worn to Limits, SC - Scheduled, UN - Unscheduled, CO - Convenience, N - Other(note in comments)

Installed Part Status: N - New, R - Repaired/Rebuilt, S - Serviceable, O - Overhauled

Repair Facility _____	Certified Repair Station Number _____	Work Order No. <u>160288</u>
Work Performed By <u>DAVE BANARES</u>	Certificate No. <u>114533-AMT</u>	Date <u>09-Feb-2016</u>
I certify that the above stated maintenance and/or inspection was performed in accordance with the current regulations of the <input type="checkbox"/> Federal Aviation Administration <input checked="" type="checkbox"/> Other (Specify) <u>CAAP</u> and _____		
THE AIRCRAFT IDENTIFIED ABOVE IS PRESENTLY AIRWORTHY AND APPROVED FOR RETURN TO SERVICE.		
Work Inspected By <u>NESTOR DERPO</u>	Certificate No. <u>119184-AMT</u>	Date <u>09-Feb-2016</u>
Pertinent details of this maintenance are on file at our facility under the above Work/Service Order Number as applicable.		

Maintenance Log	
Book	Page



Maintenance Transaction Record



This Maintenance Report is To Be Used Solely For (Check One)

Airframe Entries Eng. Serial No. PCE-VA0103 Prop. Serial No. BUA32866

CAMP Systems International
8200 E. 34TH STREET
BUILDING 1600, SUITE 1607
Wichita, KS 67226
Phone: 316-462-2267/ Fax: 316-462-0791

Aircraft Identification and Status

A/C Serial #	A/C Unit #	A/C Registration #	Date	City ID	Total A/C Hours	Total A/C Landings	Total Engine Hrs	Total Engine Cycles	Total Prop Hrs			
208B-5098		RP-C1087	03-Aug-2016	RPLL	950	1222	950	1222	950			

Component Changes, Inspections, Service Bulletins, or Airworthiness Directives Accomplished

Item	Transaction No.	Type	Item Name	Position	Part Number / Alternate Part Number	Mod Level	Part Serial	Removal Reason	Installed Part Status	TSN/TSO/TSR	Material Costs	Man Hours
051265	1	2	INSPECT 50 HR INSP-FLOATS									
Comments: CARRIED OUT INSP IAW WIPAIRE FLOATS SERVICE MANUAL 8750. SATISFACTORY												

Trans. Type: 1 - Component, 2 - Inspection, 3 - SB, 4 - AD, - - Misc.

Removal Reasons: WO - Worn to Limits, SC - Scheduled, UN - Unscheduled, CO - Convenience, N - Other(note in comments)

Installed Part Status: N - New, R - Repaired/Rebuilt, S - Serviceable, O - Overhauled

Repair Facility _____	Certified Repair Station Number _____	Work Order No. <u>160328</u>
Work Performed By <u>MIKE ANGELO MARTINES</u>	Certificate No. <u>112468-AMT</u>	Date <u>25-Jul-2016</u>
I certify that the above stated maintenance and/or inspection was performed in accordance with the current regulations of the <input type="checkbox"/> Federal Aviation Administration <input checked="" type="checkbox"/> Other (Specify) <u>CAAP</u> and _____		
THE AIRCRAFT IDENTIFIED ABOVE IS PRESENTLY AIRWORTHY AND APPROVED FOR RETURN TO SERVICE.		
Work Inspected By <u>DAVE H.BANARES</u>	Certificate No. <u>114533-AMT</u>	Date <u>25-Jul-2016</u>
Pertinent details of this maintenance are on file at our facility under the above Work/Service Order Number as applicable.		

Maintenance Log	
Book	Page



Maintenance Transaction Record



This Maintenance Report is To Be Used Solely For (Check One)

Airframe Entries Eng. Serial No. PCE-VA0103 Prop. Serial No. BUA32866

CAMP Systems International
8200 E. 34TH STREET
BUILDING 1600, SUITE 1607
Wichita, KS 67226
Phone: 316-462-2267/ Fax: 316-462-0791

Aircraft Identification and Status

A/C Serial #	A/C Unit #	A/C Registration #	Date	City ID	Total A/C Hours	Total A/C Landings	Total Engine Hrs	Total Engine Cycles	Total Prop Hrs			
208B-5098		RP-C1087	21-Jul-2016	RPLL	937.3	1207	937.3	1207	937.3			

Component Changes, Inspections, Service Bulletins, or Airworthiness Directives Accomplished

Item	Transaction No. Type	Item Name	Position	Part Number / Alternate Part Number	Mod Level	Part Serial	Removal Reason	InstalledPart Status TSN/TSO/TSR	Material Costs	Man Hours
053417	1 2	UPDATE NAV DATABASE								
Comments: PERFORMED NAVIGATION DATABASE DOWNLOAD I/AW FLY GARMIN G1000 CYCLE: 1608 EFFECTIVE: 21-JULY-18 EXPIRES: 18-AUGUST-16										

Trans. Type: 1 - Component, 2 - Inspection, 3 - SB, 4 - AD, - - Misc.

Removal Reasons: WO - Worn to Limits, SC - Scheduled, UN - Unscheduled, CO - Convenience, N - Other(note in comments)

Installed Part Status: N - New, R - Repaired/Rebuilt, S - Serviceable, O - Overhauled

Repair Facility _____	Certified Repair Station Number _____	Work Order No. <u>160311</u>
Work Performed By <u>ROMEO LERIOS</u>	Certificate No. <u>112167-AMS/AMT</u>	Date <u>19-Jul-2016</u>
I certify that the above stated maintenance and/or inspection was performed in accordance with the current regulations of the <input type="checkbox"/> Federal Aviation Administration <input checked="" type="checkbox"/> Other (Specify) <u>CAAP</u> and		
THE AIRCRAFT IDENTIFIED ABOVE IS PRESENTLY AIRWORTHY AND APPROVED FOR RETURN TO SERVICE.		
Work Inspected By <u>NESTOR DERPO</u>	Certificate No. <u>119184-AMT</u>	Date <u>19-Jul-2016</u>
Pertinent details of this maintenance are on file at our facility under the above Work/Service Order Number as applicable.		

Maintenance Log	
Book	Page



Maintenance Transaction Record



This Maintenance Report is To Be Used Solely For (Check One)

Airframe Entries Eng. Serial No. PCE-VA0103 Prop. Serial No. BUA32866

CAMP Systems International
8200 E. 34TH STREET
BUILDING 1600, SUITE 1607
Wichita, KS 67226
Phone: 316-462-2267/ Fax: 316-462-0791

Aircraft Identification and Status

A/C Serial #	A/C Unit #	A/C Registration #	Date	City ID	Total A/C Hours	Total A/C Landings	Total Engine Hrs	Total Engine Cycles	Total Prop Hrs			
208B-5098		RP-C1087	21-Jul-2016	RPLL	922.8	1184	922.8	1184	922.8			

Component Changes, Inspections, Service Bulletins, or Airworthiness Directives Accomplished

Item	Transaction No.	Type	Item Name	Position	Part Number / Alternate Part Number	Mod Level	Part Serial	Removal Reason	Installed Part Status	TSN/TSO/TSR	Material Costs	Man Hours
FAA 2016-11-20 PARA (G)	1	4	PHYSICALLY INSPECT THE PBE POUCH TO DETERMINE IF IT HAS AN INTACT VACUUM SEAL IN ACCORDANCE WITH B/E AEROSPACE SERVICE BULLETIN NO. 119003-35-011, REV .000, DATED FEBRUARY 4, 2015, PARA III.A.1 MOC: NOT APPLICABLE Comments: NOT APPLICABLE									

Trans. Type: 1 - Component, 2 - Inspection, 3 - SB, 4 - AD, - - Misc.

Removal Reasons: WO - Worn to Limits, SC - Scheduled, UN - Unscheduled, CO - Convenience, N - Other(note in comments)

Installed Part Status: N - New, R - Repaired/Rebuilt, S - Serviceable, O - Overhauled

Repair Facility _____	Certified Repair Station Number _____	Work Order No. <u>160286</u>
Work Performed By <u>DAVE BANARES</u>	Certificate No. <u>114533-AMT</u>	Date <u>01-Jul-2016</u>
I certify that the above stated maintenance and/or inspection was performed in accordance with the current regulations of the <input type="checkbox"/> Federal Aviation Administration <input checked="" type="checkbox"/> Other (Specify) <u>CAAP</u> and THE AIRCRAFT IDENTIFIED ABOVE IS PRESENTLY AIRWORTHY AND APPROVED FOR RETURN TO SERVICE.		
Work Inspected By <u>NESTOR DERPO</u>	Certificate No. <u>119184-AMT</u>	Date <u>01-Jul-2016</u>
Pertinent details of this maintenance are on file at our facility under the above Work/Service Order Number as applicable.		

Maintenance Log	
Book	Page



Maintenance Transaction Record



This Maintenance Report is To Be Used Solely For (Check One)

Airframe Entries Eng. Serial No. PCE-VA0103 Prop. Serial No. BUA32866

CAMP Systems International
8200 E. 34TH STREET
BUILDING 1600, SUITE 1607
Wichita, KS 67226
Phone: 316-462-2267/ Fax: 316-462-0791

Aircraft Identification and Status

A/C Serial #	A/C Unit #	A/C Registration #	Date	City ID	Total A/C Hours	Total A/C Landings	Total Engine Hrs	Total Engine Cycles	Total Prop Hrs			
208B-5098		RP-C1087	21-Jul-2016	RPLL	922.8	1184	922.8	1184	922.8			

Component Changes, Inspections, Service Bulletins, or Airworthiness Directives Accomplished

Item	Transaction No.	Type	Item Name	Position	Part Number / Alternate Part Number	Mod Level	Part Serial	Removal Reason	Installed Part Status	TSN/TSO/TSR	Material Costs	Man Hours
FAA 2016-11-20 PARA (H)(1)	1	4	REPLACEMENT OF A PBE POUCH, FOUND DURING THE INSPECTION IN PARAGRAPH (G) OF THIS AD, THAT DOES NOT HAVE AN INTACT VACUUM SEAL. MOC: NOT APPLICABLE Comments: NOT APPLICABLE									

Trans. Type: 1 - Component, 2 - Inspection, 3 - SB, 4 - AD, - - Misc.

Removal Reasons: WO - Worn to Limits, SC - Scheduled, UN - Unscheduled, CO - Convenience, N - Other(note in comments)

Installed Part Status: N - New, R - Repaired/Rebuilt, S - Serviceable, O - Overhauled

Repair Facility _____	Certified Repair Station Number _____	Work Order No. <u>160286</u>
Work Performed By <u>DAVE BANARES</u>	Certificate No. <u>114533-AMT</u>	Date <u>01-Jul-2016</u>
I certify that the above stated maintenance and/or inspection was performed in accordance with the current regulations of the <input type="checkbox"/> Federal Aviation Administration <input checked="" type="checkbox"/> Other (Specify) <u>CAAP</u> and _____		
THE AIRCRAFT IDENTIFIED ABOVE IS PRESENTLY AIRWORTHY AND APPROVED FOR RETURN TO SERVICE.		
Work Inspected By <u>NESTOR DERPO</u>	Certificate No. <u>119184-AMT</u>	Date <u>01-Jul-2016</u>
Pertinent details of this maintenance are on file at our facility under the above Work/Service Order Number as applicable.		

Maintenance Log	
Book	Page



Maintenance Transaction Record



This Maintenance Report is To Be Used Solely For (Check One)

Airframe Entries Eng. Serial No. PCE-VA0103 Prop. Serial No. BUA32866

CAMP Systems International
8200 E. 34TH STREET
BUILDING 1600, SUITE 1607
Wichita, KS 67226
Phone: 316-462-2267/ Fax: 316-462-0791

Aircraft Identification and Status

A/C Serial #	A/C Unit #	A/C Registration #	Date	City ID	Total A/C Hours	Total A/C Landings	Total Engine Hrs	Total Engine Cycles	Total Prop Hrs			
208B-5098		RP-C1087	04-Jul-2016	RPLL	925	1184	925	1184	925			

Component Changes, Inspections, Service Bulletins, or Airworthiness Directives Accomplished

Item	Transaction No. Type	Item Name	Position	Part Number / Alternate Part Number	Mod Level	Part Serial	Removal Reason	InstalledPart Status TSN/TSO/TSR	Material Costs	Man Hours
051260	1 2	INSPECT 25 HR INSP-FLOATS								
Comments: CARRIED OUT INSPECTION IAW WIPAIRE 8750 SERVICE MANUAL 25 HR INSP - FLOATS. SATISFACTORY										

Trans. Type: 1 - Component, 2 - Inspection, 3 - SB, 4 - AD, - - Misc.

Removal Reasons: WO - Worn to Limits, SC - Scheduled, UN - Unscheduled, CO - Convenience, N - Other(note in comments)

Installed Part Status: N - New, R - Repaired/Rebuilt, S - Serviceable, O - Overhauled

Repair Facility _____ **Certified Repair Station Number** _____ **Work Order No.** 160288
Work Performed By MIKE ANGELO MARTINES **Certificate No.** 112468-AMT **Date** 01-Jul-2016
 I certify that the above stated maintenance and/or inspection was performed in accordance with the current regulations of the
 Federal Aviation Administration Other (Specify) CAAP and
 THE AIRCRAFT IDENTIFIED ABOVE IS PRESENTLY AIRWORTHY AND APPROVED FOR RETURN TO SERVICE.
Work Inspected By DAVE H.BANARES **Certificate No.** 114533-AMT **Date** 01-Jul-2016
 Pertinent details of this maintenance are on file at our facility under the above Work/Service Order Number as applicable.

Maintenance Log	
Book	Page



Maintenance Transaction Record



This Maintenance Report is To Be Used Solely For (Check One)

Airframe Entries Eng. Serial No. PCE-VA0103 Prop. Serial No. BUA32866

CAMP Systems International
8200 E. 34TH STREET
BUILDING 1600, SUITE 1607
Wichita, KS 67226
Phone: 316-462-2267/ Fax: 316-462-0791

Aircraft Identification and Status

A/C Serial #	A/C Unit #	A/C Registration #	Date	City ID	Total A/C Hours	Total A/C Landings	Total Engine Hrs	Total Engine Cycles	Total Prop Hrs			
208B-5098		RP-C1087	28-Jun-2016	RPLL	907.1	1158	907.1	1158	907.1			

Component Changes, Inspections, Service Bulletins, or Airworthiness Directives Accomplished

Item	Transaction No.	Type	Item Name	Position	Part Number / Alternate Part Number	Mod Level	Part Serial	Removal Reason	Installed Part Status	TSN/TSO/TSR	Material Costs	Man Hours
340035	1	1	NO. 1 TRANSPONDER Comments: GTX 33 SERIAL NUMBER UPDATE Removed part no: 011-00779-10 Removed serial no: 89126249.	NO. 1	011-00779-10 S3100-474		89128030	SC	N	0 MTH 0 HRS		
340035	2	1	NO. 2 TRANSPONDER Comments: GTX 33 SERIAL NUMBER UPDATE Removed part no: 011-00779-10 Removed serial no: 89126098.	NO. 2	011-00779-10 S3100-474		89126098	SC	N	0 MTH 0 HRS		

Trans. Type: 1 - Component, 2 - Inspection, 3 - SB, 4 - AD, - - Misc.

Removal Reasons: WO - Worn to Limits, SC - Scheduled, UN - Unscheduled, CO - Convenience, N - Other(note in comments)

Installed Part Status: N - New, R - Repaired/Rebuilt, S - Serviceable, O - Overhauled

Repair Facility _____	Certified Repair Station Number _____	Work Order No. <u>160261</u>
Work Performed By <u>ROMEO LERIOS</u>	Certificate No. <u>112167-AMS/AMT</u>	Date <u>21-Jun-2016</u>
I certify that the above stated maintenance and/or inspection was performed in accordance with the current regulations of the <input type="checkbox"/> Federal Aviation Administration <input checked="" type="checkbox"/> Other (Specify) <u>CAAP</u> and THE AIRCRAFT IDENTIFIED ABOVE IS PRESENTLY AIRWORTHY AND APPROVED FOR RETURN TO SERVICE.		
Work Inspected By <u>NESTOR DERPO</u>	Certificate No. <u>119184-AMT</u>	Date <u>21-Jun-2016</u>
Pertinent details of this maintenance are on file at our facility under the above Work/Service Order Number as applicable.		

Maintenance Log	
Book	Page



Maintenance Transaction Record



This Maintenance Report is To Be Used Solely For (Check One)

Airframe Entries Eng. Serial No. PCE-VA0103 Prop. Serial No. BUA32866

CAMP Systems International
8200 E. 34TH STREET
BUILDING 1600, SUITE 1607
Wichita, KS 67226
Phone: 316-462-2267/ Fax: 316-462-0791

Aircraft Identification and Status

A/C Serial #	A/C Unit #	A/C Registration #	Date	City ID	Total A/C Hours	Total A/C Landings	Total Engine Hrs	Total Engine Cycles	Total Prop Hrs			
208B-5098		RP-C1087	28-Jun-2016	RPLL	887.6	1129	887.6	1129	887.6			

Component Changes, Inspections, Service Bulletins, or Airworthiness Directives Accomplished

Item	Transaction No. Type	Item Name	Position	Part Number / Alternate Part Number	Mod Level	Part Serial	Removal Reason	InstalledPart Status TSN/TSO/TSR	Material Costs	Man Hours
552001	1 1	LEFT ASSEMBLY ELEVATOR	LEFT	2634000-869-1		24567972	CO	S		
Comments: REMOVED AND REPLACED ELEVATOR LEFTHAND IAW C208B AMM. (REFERENCE MAINTENANCE MANUAL 55-20-00. REVV.26) SATISFACTORY REMOVED PN: 2634000-869-1 SN ON: 24567972 SN OFF: 23556312.										

Trans. Type: 1 - Component, 2 - Inspection, 3 - SB, 4 - AD, - - Misc.

Removal Reasons: WO - Worn to Limits, SC - Scheduled, UN - Unscheduled, CO - Convenience, N - Other(note in comments)

Installed Part Status: N - New, R - Repaired/Rebuilt, S - Serviceable, O - Overhauled

Repair Facility _____	Certified Repair Station Number _____	Work Order No. <u>160169</u>
Work Performed By <u>LOUIE JAY ABOG</u>	Certificate No. <u>121069-AMS/AMT</u>	Date <u>12-May-2016</u>
I certify that the above stated maintenance and/or inspection was performed in accordance with the current regulations of the <input type="checkbox"/> Federal Aviation Administration <input checked="" type="checkbox"/> Other (Specify) <u>CAAP</u> and		
THE AIRCRAFT IDENTIFIED ABOVE IS PRESENTLY AIRWORTHY AND APPROVED FOR RETURN TO SERVICE.		
Work Inspected By <u>DAVE H.BANARES</u>	Certificate No. <u>114533-AMT</u>	Date <u>12-May-2016</u>
Pertinent details of this maintenance are on file at our facility under the above Work/Service Order Number as applicable.		

Maintenance Log	
Book	Page



Maintenance Transaction Record



This Maintenance Report is To Be Used Solely For (Check One)

Airframe Entries Eng. Serial No. PCE-VA0103 Prop. Serial No. BUA32866

CAMP Systems International
8200 E. 34TH STREET
BUILDING 1600, SUITE 1607
Wichita, KS 67226
Phone: 316-462-2267/ Fax: 316-462-0791

Aircraft Identification and Status

A/C Serial #	A/C Unit #	A/C Registration #	Date	City ID	Total A/C Hours	Total A/C Landings	Total Engine Hrs	Total Engine Cycles	Total Prop Hrs			
208B-5098		RP-C1087	07-Jun-2016	RPLL	898.7	1148	898.7	1148	898.7			

Component Changes, Inspections, Service Bulletins, or Airworthiness Directives Accomplished

Item	Transaction No.	Type	Item Name	Position	Part Number / Alternate Part Number	Mod Level	Part Serial	Removal Reason	Installed Part Status	TSN/TSO/TSR	Material Costs	Man Hours
051270	1	2	INSPECT 100 HR INSP-FLOATS									
Comments: CARRIED OUT INSP. IAW 8750 WIPAIRE FLOATS SERVICE MANUAL. 100 HR FLOAT INSP. SATISFACTORY												

Trans. Type: 1 - Component, 2 - Inspection, 3 - SB, 4 - AD, - - Misc.

Removal Reasons: WO - Worn to Limits, SC - Scheduled, UN - Unscheduled, CO - Convenience, N - Other(note in comments)

Installed Part Status: N - New, R - Repaired/Rebuilt, S - Serviceable, O - Overhauled

Repair Facility _____	Certified Repair Station Number _____	Work Order No. <u>160233</u>
Work Performed By <u>MIKE ANGELO MARTINES</u>	Certificate No. <u>112468-AMT</u>	Date <u>06-Jun-2016</u>
I certify that the above stated maintenance and/or inspection was performed in accordance with the current regulations of the <input type="checkbox"/> Federal Aviation Administration <input checked="" type="checkbox"/> Other (Specify) <u>CAAP</u> and _____		
THE AIRCRAFT IDENTIFIED ABOVE IS PRESENTLY AIRWORTHY AND APPROVED FOR RETURN TO SERVICE.		
Work Inspected By <u>DAVE H.BANARES</u>	Certificate No. <u>114533-AMT</u>	Date <u>06-Jun-2016</u>
Pertinent details of this maintenance are on file at our facility under the above Work/Service Order Number as applicable.		

Maintenance Log	
Book	Page



Maintenance Transaction Record



This Maintenance Report is To Be Used Solely For (Check One)

Airframe Entries Eng. Serial No. VA0103 Prop. Serial No. BUA32866

CAMP Systems International
8200 E. 34TH STREET
BUILDING 1600, SUITE 1607
Wichita, KS 67226
Phone: 316-462-2267/ Fax: 316-462-0791

Aircraft Identification and Status

A/C Serial #	A/C Unit #	A/C Registration #	Date	City ID	Total A/C Hours	Total A/C Landings	Total Engine Hrs	Total Engine Cycles	Total Prop Hrs			
208B-5098		RP-C1087	26-May-2016	RPLL	872.5	1108	872.5	1108	872.5			

Component Changes, Inspections, Service Bulletins, or Airworthiness Directives Accomplished

Item	Transaction No. Type	Item Name	Position	Part Number / Alternate Part Number	Mod Level	Part Serial	Removal Reason	Installed Part Status TSN/TSO/TSR	Material Costs	Man Hours
051260	1 2	INSPECT 25 HR INSP-FLOATS								
Comments: CARRIED OUT INSPECTION 25-HOURS FLOAT INSPECTION IAW WIPAIRE 8750 SERVICE MANUAL. SATISFACTORY										

Trans. Type: 1 - Component, 2 - Inspection, 3 - SB, 4 - AD, - - Misc.

Removal Reasons: WO - Worn to Limits, SC - Scheduled, UN - Unscheduled, CO - Convenience, N - Other(note in comments)

Installed Part Status: N - New, R - Repaired/Rebuilt, S - Serviceable, O - Overhauled

Repair Facility _____	Certified Repair Station Number _____	Work Order No. <u>160158</u>
Work Performed By <u>MIKE ANGELO MARTINES</u>	Certificate No. <u>112468-AMT</u>	Date <u>25-Apr-2016</u>
I certify that the above stated maintenance and/or inspection was performed in accordance with the current regulations of the <input type="checkbox"/> Federal Aviation Administration <input checked="" type="checkbox"/> Other (Specify) <u>CAAP</u> and _____		
THE AIRCRAFT IDENTIFIED ABOVE IS PRESENTLY AIRWORTHY AND APPROVED FOR RETURN TO SERVICE.		
Work Inspected By <u>NESTOR DERPO</u>	Certificate No. <u>119184-AMT</u>	Date <u>25-Apr-2016</u>
Pertinent details of this maintenance are on file at our facility under the above Work/Service Order Number as applicable.		

Maintenance Log	
Book	Page



Maintenance Transaction Record



This Maintenance Report is To Be Used Solely For (Check One)

Airframe Entries Eng. Serial No. PCE-VA0103 Prop. Serial No. BUA32866

CAMP Systems International
8200 E. 34TH STREET
BUILDING 1600, SUITE 1607
Wichita, KS 67226
Phone: 316-462-2267/ Fax: 316-462-0791

Aircraft Identification and Status

A/C Serial #	A/C Unit #	A/C Registration #	Date	City ID	Total A/C Hours	Total A/C Landings	Total Engine Hrs	Total Engine Cycles	Total Prop Hrs			
208B-5098		RP-C1087	20-Apr-2016	RPLL	867.5	1100	867.5	1100	867.5			

Component Changes, Inspections, Service Bulletins, or Airworthiness Directives Accomplished

Item	Transaction No. Type	Item Name	Position	Part Number / Alternate Part Number	Mod Level	Part Serial	Removal Reason	Installed Part Status	TSN/TSO/TSR	Material Costs	Man Hours
271903	1 1	STALL WARNING LIFT TRANSDUCER		799-1		113	WO	N	0 MTH 0 HRS		
Comments: Removed part no: 799-1 Removed serial no: 154766-02./ CARRIED OUT INSPECTION IAW AMM SATISFACTORY./REMOVED AND REPLACED STALL WARNING LIFT TRANSDUCER (REV.29) ATA 27-31-00 (REV.28) PERFORMED FUNCTIONAL TEST,TESTED SATISFACTORY.											

Trans. Type: 1 - Component, 2 - Inspection, 3 - SB, 4 - AD, - - Misc.

Removal Reasons: WO - Worn to Limits, SC - Scheduled, UN - Unscheduled, CO - Convenience, N - Other(note in comments)

Installed Part Status: N - New, R - Repaired/Rebuilt, S - Serviceable, O - Overhauled

Repair Facility _____ **Certified Repair Station Number** _____ **Work Order No.** 160129

Work Performed By ROMEO LERIOS **Certificate No.** 112167-AMS/AMT **Date** 18-Apr-2016

I certify that the above stated maintenance and/or inspection was performed in accordance with the current regulations of the
 Federal Aviation Administration Other (Specify) CAAP and

THE AIRCRAFT IDENTIFIED ABOVE IS PRESENTLY AIRWORTHY AND APPROVED FOR RETURN TO SERVICE.

Work Inspected By NESTOR DERPO **Certificate No.** 119184-AMT **Date** 18-Apr-2016

Pertinent details of this maintenance are on file at our facility under the above Work/Service Order Number as applicable.

Maintenance Log	
Book	Page



Maintenance Transaction Record



This Maintenance Report is To Be Used Solely For (Check One)

Airframe Entries Eng. Serial No. PCE-VA0103 Prop. Serial No. BUA32866

CAMP Systems International
8200 E. 34TH STREET
BUILDING 1600, SUITE 1607
Wichita, KS 67226
Phone: 316-462-2267/ Fax: 316-462-0791

Aircraft Identification and Status

A/C Serial #	A/C Unit #	A/C Registration #	Date	City ID	Total A/C Hours	Total A/C Landings	Total Engine Hrs	Total Engine Cycles	Total Prop Hrs			
208B-5098		RP-C1087	13-Apr-2016	RPLL	867.5	1100	867.5	1100	867.5			

Component Changes, Inspections, Service Bulletins, or Airworthiness Directives Accomplished

Item	Transaction No. Type	Item Name	Position	Part Number / Alternate Part Number	Mod Level	Part Serial	Removal Reason	InstalledPart Status TSN/TSO/TSR	Material Costs	Man Hours
5-15-01	1 2	INSPECTION DOCUMENT 01								
Comments: CARRIED OUT INSP. IAW AMM INSP.DOC.01 SATISFACTORY. / N/A B301102,B313101,A321001,A322002,(A324001,A324005,A324009 AMPHIBIOUS),B350101,A251000.										

Trans. Type: 1 - Component, 2 - Inspection, 3 - SB, 4 - AD, - - Misc.

Removal Reasons: WO - Worn to Limits, SC - Scheduled, UN - Unscheduled, CO - Convenience, N - Other(note in comments)

Installed Part Status: N - New, R - Repaired/Rebuilt, S - Serviceable, O - Overhauled

Repair Facility _____	Certified Repair Station Number _____	Work Order No. <u>160100</u>
Work Performed By <u>DAVE BANARES</u>	Certificate No. <u>114533-AMT</u>	Date <u>28-Apr-2016</u>
I certify that the above stated maintenance and/or inspection was performed in accordance with the current regulations of the <input type="checkbox"/> Federal Aviation Administration <input checked="" type="checkbox"/> Other (Specify) <u>CAAP</u> and		
THE AIRCRAFT IDENTIFIED ABOVE IS PRESENTLY AIRWORTHY AND APPROVED FOR RETURN TO SERVICE.		
Work Inspected By <u>NESTOR DERPO</u>	Certificate No. <u>119184-AMT</u>	Date <u>28-Apr-2016</u>
Pertinent details of this maintenance are on file at our facility under the above Work/Service Order Number as applicable.		

Maintenance Log	
Book	Page



Maintenance Transaction Record



This Maintenance Report is To Be Used Solely For (Check One)

Airframe Entries Eng. Serial No. PCE-VA0103 Prop. Serial No. BUA32866

CAMP Systems International
8200 E. 34TH STREET
BUILDING 1600, SUITE 1607
Wichita, KS 67226
Phone: 316-462-2267/ Fax: 316-462-0791

Aircraft Identification and Status

A/C Serial #	A/C Unit #	A/C Registration #	Date	City ID	Total A/C Hours	Total A/C Landings	Total Engine Hrs	Total Engine Cycles	Total Prop Hrs			
208B-5098		RP-C1087	13-Apr-2016	RPLL	867.5	1100	867.5	1100	867.5			

Component Changes, Inspections, Service Bulletins, or Airworthiness Directives Accomplished

Item	Transaction No. Type	Item Name	Position	Part Number / Alternate Part Number	Mod Level	Part Serial	Removal Reason	Installed Part Status TSN/TSO/TSR	Material Costs	Man Hours
5-15-21	1 2	INSPECTION DOCUMENT 21								
Comments: PERFORMED INSPECTION DOCUMENT 21 IAW A.M.M./ COMPLIED ALTIMETER,PITOT/STATIC & ALTITUDE REPORTING SYSTEM TEST & INSP. IAW CESSNA MM,1985 & ON MODEL 208 SERIES,PITOT/STATIC SYSTEM-INSP./CHECK,ATA 34-11-00,REV.30,DATED 01 DECEMBER 2015,AS REQUIRED BY CAAP CAR PART 8.2.1.7(a)(3),TESTED WITHIN ACCEPTABLE TOLERANCE.										

Trans. Type: 1 - Component, 2 - Inspection, 3 - SB, 4 - AD, - - Misc.

Removal Reasons: WO - Worn to Limits, SC - Scheduled, UN - Unscheduled, CO - Convenience, N - Other(note in comments)

Installed Part Status: N - New, R - Repaired/Rebuilt, S - Serviceable, O - Overhauled

Repair Facility _____	Certified Repair Station Number _____	Work Order No. <u>160119</u>
Work Performed By <u>ROMEO LERIOS</u>	Certificate No. <u>112167-AMS/AMT</u>	Date <u>05-Apr-2016</u>
I certify that the above stated maintenance and/or inspection was performed in accordance with the current regulations of the <input type="checkbox"/> Federal Aviation Administration <input checked="" type="checkbox"/> Other (Specify) <u>CAAP</u> and		
THE AIRCRAFT IDENTIFIED ABOVE IS PRESENTLY AIRWORTHY AND APPROVED FOR RETURN TO SERVICE.		
Work Inspected By <u>NESTOR DERPO</u>	Certificate No. <u>119184-AMT</u>	Date <u>05-Apr-2016</u>
Pertinent details of this maintenance are on file at our facility under the above Work/Service Order Number as applicable.		

Maintenance Log	
Book	Page



Maintenance Transaction Record



This Maintenance Report is To Be Used Solely For (Check One)

Airframe Entries Eng. Serial No. PCE-VA0103 Prop. Serial No. BUA32866

CAMP Systems International
8200 E. 34TH STREET
BUILDING 1600, SUITE 1607
Wichita, KS 67226
Phone: 316-462-2267/ Fax: 316-462-0791

Aircraft Identification and Status

A/C Serial #	A/C Unit #	A/C Registration #	Date	City ID	Total A/C Hours	Total A/C Landings	Total Engine Hrs	Total Engine Cycles	Total Prop Hrs			
208B-5098		RP-C1087	13-Apr-2016	RPLL	867.5	1100	867.5	1100	867.5			

Component Changes, Inspections, Service Bulletins, or Airworthiness Directives Accomplished

Item	Transaction No.	Type	Item Name	Position	Part Number / Alternate Part Number	Mod Level	Part Serial	Removal Reason	Installed Part Status	TSN/TSO/TSR	Material Costs	Man Hours
370102	1	1	VACUUM SYSTEM CENTRAL AIR FILTER DISCARD		C294502-0201	D9-18-1	N/A	SC	N	867 MTH 0 HRS		

Comments: Removed part no: PN AA D9-18-1 Removed serial no: SN-UNKNOWN. / NOTE: NEXT CHANGE AT 1267.5 A/F HRS.

Trans. Type: 1 - Component, 2 - Inspection, 3 - SB, 4 - AD, - - Misc.

Removal Reasons: WO - Worn to Limits, SC - Scheduled, UN - Unscheduled, CO - Convenience, N - Other(note in comments)

Installed Part Status: N - New, R - Repaired/Rebuilt, S - Serviceable, O - Overhauled

Repair Facility _____	Certified Repair Station Number _____	Work Order No. <u>160117</u>
Work Performed By <u>DAVE BANARES</u>	Certificate No. <u>114533-AMT</u>	Date <u>04-Apr-2016</u>
I certify that the above stated maintenance and/or inspection was performed in accordance with the current regulations of the <input type="checkbox"/> Federal Aviation Administration <input checked="" type="checkbox"/> Other (Specify) <u>CAAP</u> and		
THE AIRCRAFT IDENTIFIED ABOVE IS PRESENTLY AIRWORTHY AND APPROVED FOR RETURN TO SERVICE.		
Work Inspected By <u>NESTOR DERPO</u>	Certificate No. <u>119184-AMT</u>	Date <u>04-Apr-2016</u>
Pertinent details of this maintenance are on file at our facility under the above Work/Service Order Number as applicable.		

Maintenance Log	
Book	Page



Maintenance Transaction Record



This Maintenance Report is To Be Used Solely For (Check One)

Airframe Entries Eng. Serial No. PCE-VA0103 Prop. Serial No. BUA 32866

CAMP Systems International
8200 E. 34TH STREET
BUILDING 1600, SUITE 1607
Wichita, KS 67226
Phone: 316-462-2267/ Fax: 316-462-0791

Aircraft Identification and Status

A/C Serial #	A/C Unit #	A/C Registration #	Date	City ID	Total A/C Hours	Total A/C Landings	Total Engine Hrs	Total Engine Cycles	Total Prop Hrs			
208B-5098		RP-C1087	13-Apr-2016	RPLL	867.5	1100	867.5	1100	867.5			

Component Changes, Inspections, Service Bulletins, or Airworthiness Directives Accomplished

Item	Transaction No. Type	Item Name	Position	Part Number / Alternate Part Number	Mod Level	Part Serial	Removal Reason	Installed Part Status	TSN/TSO/TSR	Material Costs	Man Hours
370103	1 1	VACUUM RELIEF VALVE FILTER DISCARD		B3-5-1		1Q14	SC	N	867 MTH 0 HRS		
Comments: Removed part no: PN/B3-5-1 Removed serial no: SN-UNKNOWN/ NOTE:NEXT CHANGE AT 1267.5 A/F HRS.											

Trans. Type: 1 - Component, 2 - Inspection, 3 - SB, 4 - AD, - - Misc.

Removal Reasons: WO - Worn to Limits, SC - Scheduled, UN - Unscheduled, CO - Convenience, N - Other(note in comments)

Installed Part Status: N - New, R - Repaired/Rebuilt, S - Serviceable, O - Overhauled

Repair Facility _____	Certified Repair Station Number _____	Work Order No. <u>160117</u>
Work Performed By <u>DAVE BANARES</u>	Certificate No. <u>114533-AMT</u>	Date <u>04-Apr-2016</u>
I certify that the above stated maintenance and/or inspection was performed in accordance with the current regulations of the <input type="checkbox"/> Federal Aviation Administration <input checked="" type="checkbox"/> Other (Specify) <u>CAAP</u> and		
THE AIRCRAFT IDENTIFIED ABOVE IS PRESENTLY AIRWORTHY AND APPROVED FOR RETURN TO SERVICE.		
Work Inspected By <u>NESTOR DERPO</u>	Certificate No. <u>119184-AMT</u>	Date <u>04-Apr-2016</u>
Pertinent details of this maintenance are on file at our facility under the above Work/Service Order Number as applicable.		

Maintenance Log	
Book	Page



Maintenance Transaction Record



This Maintenance Report is To Be Used Solely For (Check One)

Airframe Entries Eng. Serial No. PCE-VA0103 Prop. Serial No. BUA32866

CAMP Systems International
8200 E. 34TH STREET
BUILDING 1600, SUITE 1607
Wichita, KS 67226
Phone: 316-462-2267/ Fax: 316-462-0791

Aircraft Identification and Status

A/C Serial #	A/C Unit #	A/C Registration #	Date	City ID	Total A/C Hours	Total A/C Landings	Total Engine Hrs	Total Engine Cycles	Total Prop Hrs			
208B-5098		RP-C1087	14-Apr-2016	RPLL	867.5	1100	867.5	1100	867.5			

Component Changes, Inspections, Service Bulletins, or Airworthiness Directives Accomplished

Item	Transaction No.	Type	Item Name	Position	Part Number / Alternate Part Number	Mod Level	Part Serial	Removal Reason	Installed Part Status	TSN/TSO/TSR	Material Costs	Man Hours
B262001	1	2	WEIGHT CHECK FORWARD FIRE EXTINGUISHER PORTABLE	FORWARD	C352TS		Y-649628					
Weight Check Date: 10-Mar-2016 Comments: CARRIED OUT INSPECTION IAW AMM INSP. DOC.01 SATISFACTORY. /NOTE:NEXT DUE AT 10 MARCH,2017.												

Trans. Type: 1 - Component, 2 - Inspection, 3 - SB, 4 - AD, - - Misc.

Removal Reasons: WO - Worn to Limits, SC - Scheduled, UN - Unscheduled, CO - Convenience, N - Other(note in comments)

Installed Part Status: N - New, R - Repaired/Rebuilt, S - Serviceable, O - Overhauled

Repair Facility _____	Certified Repair Station Number _____	Work Order No. <u>160100</u>
Work Performed By <u>DAVE BANARES</u>	Certificate No. <u>114533-AMT</u>	Date <u>10-Mar-2016</u>
I certify that the above stated maintenance and/or inspection was performed in accordance with the current regulations of the <input type="checkbox"/> Federal Aviation Administration <input checked="" type="checkbox"/> Other (Specify) <u>CAAP</u> and		
THE AIRCRAFT IDENTIFIED ABOVE IS PRESENTLY AIRWORTHY AND APPROVED FOR RETURN TO SERVICE.		
Work Inspected By <u>NESTOR DERPO</u>	Certificate No. <u>119184-AMT</u>	Date <u>10-Mar-2016</u>
Pertinent details of this maintenance are on file at our facility under the above Work/Service Order Number as applicable.		

Maintenance Log	
Book	Page



Maintenance Transaction Record



This Maintenance Report is To Be Used Solely For (Check One)

Airframe Entries Eng. Serial No. PCE-VA0103 Prop. Serial No. BUA32866

CAMP Systems International
8200 E. 34TH STREET
BUILDING 1600, SUITE 1607
Wichita, KS 67226
Phone: 316-462-2267/ Fax: 316-462-0791

Aircraft Identification and Status

A/C Serial #	A/C Unit #	A/C Registration #	Date	City ID	Total A/C Hours	Total A/C Landings	Total Engine Hrs	Total Engine Cycles	Total Prop Hrs			
208B-5098		RP-C1087	14-Apr-2016	RPLL	867.5	1100	867.5	1100	867.5			

Component Changes, Inspections, Service Bulletins, or Airworthiness Directives Accomplished

Item	Transaction No. Type	Item Name	Position	Part Number / Alternate Part Number	Mod Level	Part Serial	Removal Reason	InstalledPart Status TSN/TSO/TSR	Material Costs	Man Hours
5-15-06	1 2	INSPECTION DOCUMENT 06								
Comments: CARRIED OUT INSPECTION IAW AMM INSPECTION DOC.06 SATISFACTORY./ N/A (D121001,D121003,C122101/AMPHIBIOUS),B243401,A255101,B353001,A353001.										

Trans. Type: 1 - Component, 2 - Inspection, 3 - SB, 4 - AD, - - Misc.

Removal Reasons: WO - Worn to Limits, SC - Scheduled, UN - Unscheduled, CO - Convenience, N - Other(note in comments)

Installed Part Status: N - New, R - Repaired/Rebuilt, S - Serviceable, O - Overhauled

Repair Facility _____	Certified Repair Station Number _____	Work Order No. <u>160100</u>
Work Performed By <u>DAVE BANARES</u>	Certificate No. <u>114533-AMT</u>	Date <u>10-Mar-2016</u>
I certify that the above stated maintenance and/or inspection was performed in accordance with the current regulations of the <input type="checkbox"/> Federal Aviation Administration <input checked="" type="checkbox"/> Other (Specify) <u>CAAP</u> and _____		
THE AIRCRAFT IDENTIFIED ABOVE IS PRESENTLY AIRWORTHY AND APPROVED FOR RETURN TO SERVICE.		
Work Inspected By <u>NESTOR DERPO</u>	Certificate No. <u>119184-AMT</u>	Date <u>10-Mar-2016</u>
Pertinent details of this maintenance are on file at our facility under the above Work/Service Order Number as applicable.		

Maintenance Log	
Book	Page



Maintenance Transaction Record



This Maintenance Report is To Be Used Solely For (Check One)

Airframe Entries Eng. Serial No. PCE-VA0103 Prop. Serial No. BUA32866

CAMP Systems International
8200 E. 34TH STREET
BUILDING 1600, SUITE 1607
Wichita, KS 67226
Phone: 316-462-2267/ Fax: 316-462-0791

Aircraft Identification and Status

A/C Serial #	A/C Unit #	A/C Registration #	Date	City ID	Total A/C Hours	Total A/C Landings	Total Engine Hrs	Total Engine Cycles	Total Prop Hrs			
208B-5098		RP-C1087	14-Apr-2016	RPLL	867.5	1100	867.5	1100	867.5			

Component Changes, Inspections, Service Bulletins, or Airworthiness Directives Accomplished

Item	Transaction No.	Type	Item Name	Position	Part Number / Alternate Part Number	Mod Level	Part Serial	Removal Reason	Installed Part Status	TSN/TSO/TSR	Material Costs	Man Hours
5-15-10	1	2	INSPECTION DOCUMENT 10									
Comments: CARRIED OUT INSPECTION IAW AMM INSPECTION DOCUMENT 10 SATISFACTORY./N/A B313103,B324001.												

Trans. Type: 1 - Component, 2 - Inspection, 3 - SB, 4 - AD, - - Misc.

Removal Reasons: WO - Worn to Limits, SC - Scheduled, UN - Unscheduled, CO - Convenience, N - Other(note in comments)

Installed Part Status: N - New, R - Repaired/Rebuilt, S - Serviceable, O - Overhauled

Repair Facility _____	Certified Repair Station Number _____	Work Order No. <u>160100</u>
Work Performed By <u>DAVE BANARES</u>	Certificate No. <u>114533-AMT</u>	Date <u>08-Mar-2016</u>
I certify that the above stated maintenance and/or inspection was performed in accordance with the current regulations of the <input type="checkbox"/> Federal Aviation Administration <input checked="" type="checkbox"/> Other (Specify) <u>CAAP</u> and		
THE AIRCRAFT IDENTIFIED ABOVE IS PRESENTLY AIRWORTHY AND APPROVED FOR RETURN TO SERVICE.		
Work Inspected By <u>NESTOR DERPO</u>	Certificate No. <u>119184-AMT</u>	Date <u>08-Mar-2016</u>
Pertinent details of this maintenance are on file at our facility under the above Work/Service Order Number as applicable.		

Maintenance Log	
Book	Page



Maintenance Transaction Record



This Maintenance Report is To Be Used Solely For (Check One)

Airframe Entries Eng. Serial No. PCE-VA0103 Prop. Serial No. BUA32866

CAMP Systems International
8200 E. 34TH STREET
BUILDING 1600, SUITE 1607
Wichita, KS 67226
Phone: 316-462-2267/ Fax: 316-462-0791

Aircraft Identification and Status

A/C Serial #	A/C Unit #	A/C Registration #	Date	City ID	Total A/C Hours	Total A/C Landings	Total Engine Hrs	Total Engine Cycles	Total Prop Hrs			
208B-5098		RP-C1087	14-Apr-2016	RPLL	867.5	1100	867.5	1100	867.5			

Component Changes, Inspections, Service Bulletins, or Airworthiness Directives Accomplished

Item	Transaction No.	Type	Item Name	Position	Part Number / Alternate Part Number	Mod Level	Part Serial	Removal Reason	Installed Part Status	TSN/TSO/TSR	Material Costs	Man Hours
5-15-02	1	2	INSPECTION DOCUMENT 02									
Comments: CARRIED OUT INSPECTION IAW AMM INSPECTION DOC.02 SATISFACTORY./ N/A B341104,B341105.												

Trans. Type: 1 - Component, 2 - Inspection, 3 - SB, 4 - AD, - - Misc.

Removal Reasons: WO - Worn to Limits, SC - Scheduled, UN - Unscheduled, CO - Convenience, N - Other(note in comments)

Installed Part Status: N - New, R - Repaired/Rebuilt, S - Serviceable, O - Overhauled

Repair Facility _____	Certified Repair Station Number _____	Work Order No. <u>160100</u>
Work Performed By <u>DAVE BANARES</u>	Certificate No. <u>114533-AMT</u>	Date <u>07-Mar-2016</u>
I certify that the above stated maintenance and/or inspection was performed in accordance with the current regulations of the <input type="checkbox"/> Federal Aviation Administration <input checked="" type="checkbox"/> Other (Specify) <u>CAAP</u> and		
THE AIRCRAFT IDENTIFIED ABOVE IS PRESENTLY AIRWORTHY AND APPROVED FOR RETURN TO SERVICE.		
Work Inspected By <u>NESTOR DERPO</u>	Certificate No. <u>119184-AMT</u>	Date <u>07-Mar-2016</u>
Pertinent details of this maintenance are on file at our facility under the above Work/Service Order Number as applicable.		

Maintenance Log	
Book	Page



Maintenance Transaction Record



This Maintenance Report is To Be Used Solely For (Check One)

Airframe Entries Eng. Serial No. PCE-VA0103 Prop. Serial No. BUA32866

CAMP Systems International
8200 E. 34TH STREET
BUILDING 1600, SUITE 1607
Wichita, KS 67226
Phone: 316-462-2267/ Fax: 316-462-0791

Aircraft Identification and Status

A/C Serial #	A/C Unit #	A/C Registration #	Date	City ID	Total A/C Hours	Total A/C Landings	Total Engine Hrs	Total Engine Cycles	Total Prop Hrs			
208B-5098		RP-C1087	14-Apr-2016	RPLL	867.5	1100	867.5	1100	867.5			

Component Changes, Inspections, Service Bulletins, or Airworthiness Directives Accomplished

Item	Transaction No. Type	Item Name	Position	Part Number / Alternate Part Number	Mod Level	Part Serial	Removal Reason	InstalledPart Status TSN/TSO/TSR	Material Costs	Man Hours
5-15-08	1 2	INSPECTION DOCUMENT 08								
Comments: CARRIED OUT INSPECTION IAW AMM INSPECTION DOCUMENT 08 SATISFACTORY./N/A A322001 AMPHIBIOUS.										

Trans. Type: 1 - Component, 2 - Inspection, 3 - SB, 4 - AD, - - Misc.

Removal Reasons: WO - Worn to Limits, SC - Scheduled, UN - Unscheduled, CO - Convenience, N - Other(note in comments)

Installed Part Status: N - New, R - Repaired/Rebuilt, S - Serviceable, O - Overhauled

Repair Facility _____	Certified Repair Station Number _____	Work Order No. <u>160100</u>
Work Performed By <u>DAVE BANARES</u>	Certificate No. <u>114533-AMT</u>	Date <u>07-Mar-2016</u>
I certify that the above stated maintenance and/or inspection was performed in accordance with the current regulations of the <input type="checkbox"/> Federal Aviation Administration <input checked="" type="checkbox"/> Other (Specify) <u>CAAP</u> and		
THE AIRCRAFT IDENTIFIED ABOVE IS PRESENTLY AIRWORTHY AND APPROVED FOR RETURN TO SERVICE.		
Work Inspected By <u>NESTOR DERPO</u>	Certificate No. <u>119184-AMT</u>	Date <u>07-Mar-2016</u>
Pertinent details of this maintenance are on file at our facility under the above Work/Service Order Number as applicable.		

Maintenance Log	
Book	Page



Maintenance Transaction Record



This Maintenance Report is To Be Used Solely For (Check One)

Airframe Entries Eng. Serial No. PCE-VA0103 Prop. Serial No. BUA32866

CAMP Systems International
8200 E. 34TH STREET
BUILDING 1600, SUITE 1607
Wichita, KS 67226
Phone: 316-462-2267/ Fax: 316-462-0791

Aircraft Identification and Status

A/C Serial #	A/C Unit #	A/C Registration #	Date	City ID	Total A/C Hours	Total A/C Landings	Total Engine Hrs	Total Engine Cycles	Total Prop Hrs			
208B-5098		RP-C1087	14-Apr-2016	RPLL	867.5	1100	867.5	1100	867.5			

Component Changes, Inspections, Service Bulletins, or Airworthiness Directives Accomplished

Item	Transaction No.	Type	Item Name	Position	Part Number / Alternate Part Number	Mod Level	Part Serial	Removal Reason	Installed Part Status	TSN/TSO/TSR	Material Costs	Man Hours
5-15-09	1	2	INSPECTION DOCUMENT 09									
Comments: CARRIED OUT INSPECTION IAW AMM INSPECTION DOC.09 SATISFACTORY./ N/A B243201.												

Trans. Type: 1 - Component, 2 - Inspection, 3 - SB, 4 - AD, - - Misc.

Removal Reasons: WO - Worn to Limits, SC - Scheduled, UN - Unscheduled, CO - Convenience, N - Other(note in comments)

Installed Part Status: N - New, R - Repaired/Rebuilt, S - Serviceable, O - Overhauled

Repair Facility _____	Certified Repair Station Number _____	Work Order No. <u>160100</u>
Work Performed By <u>ROMEO LERIOS</u>	Certificate No. <u>112167-AMS/AMT</u>	Date <u>05-Mar-2016</u>
I certify that the above stated maintenance and/or inspection was performed in accordance with the current regulations of the <input type="checkbox"/> Federal Aviation Administration <input checked="" type="checkbox"/> Other (Specify) <u>CAAP</u> and		
THE AIRCRAFT IDENTIFIED ABOVE IS PRESENTLY AIRWORTHY AND APPROVED FOR RETURN TO SERVICE.		
Work Inspected By <u>NESTOR DERPO</u>	Certificate No. <u>119184-AMT</u>	Date <u>05-Mar-2016</u>
Pertinent details of this maintenance are on file at our facility under the above Work/Service Order Number as applicable.		

Maintenance Log	
Book	Page



Maintenance Transaction Record



This Maintenance Report is To Be Used Solely For (Check One)

Airframe Entries Eng. Serial No. _____ Prop. Serial No. _____

CAMP Systems International
8200 E. 34TH STREET
BUILDING 1600, SUITE 1607
Wichita, KS 67226
Phone: 316-462-2267/ Fax: 316-462-0791

Aircraft Identification and Status

A/C Serial #	A/C Unit #	A/C Registration #	Date	City ID	Total A/C Hours	Total A/C Landings	Total Engine Hrs	Total Engine Cycles	Total Prop Hrs			
208B-5098		RP-C1087	13-Mar-2016	MNL	848.1	1066	848.1	1066	848.1			

Component Changes, Inspections, Service Bulletins, or Airworthiness Directives Accomplished

Item	Transaction No.	Type	Item Name	Position	Part Number / Alternate Part Number	Mod Level	Part Serial	Removal Reason	Installed Part Status	TSN/TSO/TSR	Material Costs	Man Hours
051265	1	2	INSPECT 50 HR INSP-FLOATS									
Comments:												

Trans. Type: 1 - Component, 2 - Inspection, 3 - SB, 4 - AD, - - Misc.

Removal Reasons: WO - Worn to Limits, SC - Scheduled, UN - Unscheduled, CO - Convenience, N - Other(note in comments)

Installed Part Status: N - New, R - Repaired/Rebuilt, S - Serviceable, O - Overhauled

Repair Facility _____	Certified Repair Station Number _____	Work Order No. 160081
Work Performed By ARIEL JASON DAYRIT	Certificate No. 102495AMT	Date 13-Mar-2016
I certify that the above stated maintenance and/or inspection was performed in accordance with the current regulations of the <input type="checkbox"/> Federal Aviation Administration <input checked="" type="checkbox"/> Other (Specify) CAAP _____ and THE AIRCRAFT IDENTIFIED ABOVE IS PRESENTLY AIRWORTHY AND APPROVED FOR RETURN TO SERVICE.		
Work Inspected By NESTOR DERPO	Certificate No. 119184AMT	Date 13-Mar-2016
Pertinent details of this maintenance are on file at our facility under the above Work/Service Order Number as applicable.		

Maintenance Log	
Book	Page



Maintenance Transaction Record



This Maintenance Report is To Be Used Solely For (Check One)

Airframe Entries
 Eng. Serial No. _____
 Prop. Serial No. _____

CAMP Systems International
 8200 E. 34TH STREET
 BUILDING 1600, SUITE 1607
 Wichita, KS 67226
 Phone: 316-462-2267/ Fax: 316-462-0791

Aircraft Identification and Status

A/C Serial #	A/C Unit #	A/C Registration #	Date	City ID	Total A/C Hours	Total A/C Landings	Total Engine Hrs	Total Engine Cycles	Total Prop Hrs			
208B-5098		RP-C1087	10-Mar-2016	MNL	839.7	1063	839.7	1063	839.7			

Component Changes, Inspections, Service Bulletins, or Airworthiness Directives Accomplished

Item	Transaction No.	Type	Item Name	Position	Part Number / Alternate Part Number	Mod Level	Part Serial	Removal Reason	Installed Part Status	TSN/TSO/TSR	Material Costs	Man Hours
321108F	1	1	RIGHT OUTBOARD BRAKE DISC Comments: Removed part no: PN Removed serial no: NSN.	RIGHT OUTBOARD			NSN	WO	N	0 MTH 0 HRS		
321110F 321110F : RO	2	1	RIGHT OUTBOARD BRAKE BACK PLATE Comments: Removed part no: PN074-02900 Removed serial no: NSN.	RIGHT OUTBOARD	PN074-02900		NSN	WO	N	0 MTH 0 HRS		

Trans. Type: 1 - Component, 2 - Inspection, 3 - SB, 4 - AD, - - Misc.

Removal Reasons: WO - Worn to Limits, SC - Scheduled, UN - Unscheduled, CO - Convenience, N - Other(note in comments)

Installed Part Status: N - New, R - Repaired/Rebuilt, S - Serviceable, O - Overhauled

Repair Facility _____ Certified Repair Station Number _____ Work Order No. _____ Work Performed By <u>MIKE ANGELO MARTINEZ</u> Certificate No. <u>112468 AMT</u> Date <u>10-Mar-2016</u> I certify that the above stated maintenance and/or inspection was performed in accordance with the current regulations of the <input type="checkbox"/> Federal Aviation Administration <input checked="" type="checkbox"/> Other (Specify) <u>CAAP</u> and _____ THE AIRCRAFT IDENTIFIED ABOVE IS PRESENTLY AIRWORTHY AND APPROVED FOR RETURN TO SERVICE. Work Inspected By <u>DAVE BANARES</u> Certificate No. <u>114533AMT</u> Date <u>10-Mar-2016</u> Pertinent details of this maintenance are on file at our facility under the above Work/Service Order Number as applicable.
--

Maintenance Log	
Book	Page



Maintenance Transaction Record



This Maintenance Report is To Be Used Solely For (Check One)

Airframe Entries Eng. Serial No. _____ Prop. Serial No. _____

CAMP Systems International
8200 E. 34TH STREET
BUILDING 1600, SUITE 1607
Wichita, KS 67226
Phone: 316-462-2267/ Fax: 316-462-0791

Aircraft Identification and Status

A/C Serial #	A/C Unit #	A/C Registration #	Date	City ID	Total A/C Hours	Total A/C Landings	Total Engine Hrs	Total Engine Cycles	Total Prop Hrs			
208B-5098		RP-C1087	29-Feb-2016	MNL	827.4	1044	827.4	1044	827.4			

Component Changes, Inspections, Service Bulletins, or Airworthiness Directives Accomplished

Item	Transaction No.	Type	Item Name	Position	Part Number / Alternate Part Number	Mod Level	Part Serial	Removal Reason	Installed Part Status	TSN/TSO/TSR	Material Costs	Man Hours
051260	1	2	INSPECT 25 HR INSP-FLOATS									
Comments:												

Trans. Type: 1 - Component, 2 - Inspection, 3 - SB, 4 - AD, - - Misc.

Removal Reasons: WO - Worn to Limits, SC - Scheduled, UN - Unscheduled, CO - Convenience, N - Other(note in comments)

Installed Part Status: N - New, R - Repaired/Rebuilt, S - Serviceable, O - Overhauled

Repair Facility _____ **Certified Repair Station Number** _____ **Work Order No.** 160068
Work Performed By DAVE BANARES **Certificate No.** 114533AMT **Date** 29-Feb-2016
 I certify that the above stated maintenance and/or inspection was performed in accordance with the current regulations of the
 Federal Aviation Administration Other (Specify) CAAP _____ and
 THE AIRCRAFT IDENTIFIED ABOVE IS PRESENTLY AIRWORTHY AND APPROVED FOR RETURN TO SERVICE.
Work Inspected By NES **Certificate No.** _____ **Date** 29-Feb-2016
 Pertinent details of this maintenance are on file at our facility under the above Work/Service Order Number as applicable.

Maintenance Log	
Book	Page



Maintenance Transaction Record



This Maintenance Report is To Be Used Solely For (Check One)

Airframe Entries
 Eng. Serial No. _____
 Prop. Serial No. _____

CAMP Systems International
 8200 E. 34TH STREET
 BUILDING 1600, SUITE 1607
 Wichita, KS 67226
 Phone: 316-462-2267/ Fax: 316-462-0791

Aircraft Identification and Status

A/C Serial #	A/C Unit #	A/C Registration #	Date	City ID	Total A/C Hours	Total A/C Landings	Total Engine Hrs	Total Engine Cycles	Total Prop Hrs			
208B-5098		RP-C1087	14-Feb-2016	MNL	803.1	1019	803.1	1019	803.1			

Component Changes, Inspections, Service Bulletins, or Airworthiness Directives Accomplished

Item	Transaction No.	Type	Item Name	Position	Part Number / Alternate Part Number	Mod Level	Part Serial	Removal Reason	Installed Part Status	TSN/TSO/TSR	Material Costs	Man Hours
051270	1	2	INSPECT 100 HR INSP-FLOATS									
Comments:												
051265	2	2	INSPECT 50 HR INSP-FLOATS									
Comments:												
051260	3	2	INSPECT 25 HR INSP-FLOATS									
Comments:												

Trans. Type: 1 - Component, 2 - Inspection, 3 - SB, 4 - AD, - - Misc.

Removal Reasons: WO - Worn to Limits, SC - Scheduled, UN - Unscheduled, CO - Convenience, N - Other(note in comments)

Installed Part Status: N - New, R - Repaired/Rebuilt, S - Serviceable, O - Overhauled

Repair Facility _____	Certified Repair Station Number _____	Work Order No. 160050
Work Performed By CHAZ MICHAEL C DATU	Certificate No. 126124AMT	Date 14-Feb-2016
I certify that the above stated maintenance and/or inspection was performed in accordance with the current regulations of the <input type="checkbox"/> Federal Aviation Administration <input checked="" type="checkbox"/> Other (Specify) CAAP _____ and _____		
THE AIRCRAFT IDENTIFIED ABOVE IS PRESENTLY AIRWORTHY AND APPROVED FOR RETURN TO SERVICE.		
Work Inspected By DAVE BANARES	Certificate No. 114533AMT	Date 14-Feb-2016
Pertinent details of this maintenance are on file at our facility under the above Work/Service Order Number as applicable.		

Maintenance Log	
Book	Page



Maintenance Transaction Record



This Maintenance Report is To Be Used Solely For (Check One)

Airframe Entries
 Eng. Serial No. _____
 Prop. Serial No. _____

CAMP Systems International
 8200 E. 34TH STREET
 BUILDING 1600, SUITE 1607
 Wichita, KS 67226
 Phone: 316-462-2267/ Fax: 316-462-0791

Aircraft Identification and Status

A/C Serial #	A/C Unit #	A/C Registration #	Date	City ID	Total A/C Hours	Total A/C Landings	Total Engine Hrs	Total Engine Cycles	Total Prop Hrs			
208B-5098		RP-C1087	08-Feb-2016	MNL	775.3	981	775.3	981	775.3			

Component Changes, Inspections, Service Bulletins, or Airworthiness Directives Accomplished

Item	Transaction No.	Type	Item Name	Position	Part Number / Alternate Part Number	Mod Level	Part Serial	Removal Reason	Installed Part Status	TSN/TSO/TSR	Material Costs	Man Hours
051260	1	2	INSPECT 25 HR INSP-FLOATS									
Comments:												

Trans. Type: 1 - Component, 2 - Inspection, 3 - SB, 4 - AD, - - Misc.

Removal Reasons: WO - Worn to Limits, SC - Scheduled, UN - Unscheduled, CO - Convenience, N - Other(note in comments)

Installed Part Status: N - New, R - Repaired/Rebuilt, S - Serviceable, O - Overhauled

Repair Facility _____	Certified Repair Station Number _____	Work Order No. 160045
Work Performed By DAVE BANARES	Certificate No. 114533AMT	Date 08-Feb-2016
I certify that the above stated maintenance and/or inspection was performed in accordance with the current regulations of the <input type="checkbox"/> Federal Aviation Administration <input checked="" type="checkbox"/> Other (Specify) CAAP _____ and _____		
THE AIRCRAFT IDENTIFIED ABOVE IS PRESENTLY AIRWORTHY AND APPROVED FOR RETURN TO SERVICE.		
Work Inspected By NESTOR DERPO	Certificate No. 119184AMT	Date 08-Feb-2016
Pertinent details of this maintenance are on file at our facility under the above Work/Service Order Number as applicable.		

Maintenance Log	
Book	Page



Maintenance Transaction Record



This Maintenance Report is To Be Used Solely For (Check One)

Airframe Entries
 Eng. Serial No. _____
 Prop. Serial No. _____

CAMP Systems International
 8200 E. 34TH STREET
 BUILDING 1600, SUITE 1607
 Wichita, KS 67226
 Phone: 316-462-2267/ Fax: 316-462-0791

Aircraft Identification and Status

A/C Serial #	A/C Unit #	A/C Registration #	Date	City ID	Total A/C Hours	Total A/C Landings	Total Engine Hrs	Total Engine Cycles	Total Prop Hrs			
208B-5098		RP-C1087	30-Jan-2016	MNL	749	940	749	940	749			

Component Changes, Inspections, Service Bulletins, or Airworthiness Directives Accomplished

Item	Transaction No.	Type	Item Name	Position	Part Number / Alternate Part Number	Mod Level	Part Serial	Removal Reason	Installed Part Status	TSN/TSO/TSR	Material Costs	Man Hours
051265	1	2	INSPECT 50 HR INSP-FLOATS									
Comments:												
051260	2	2	INSPECT 25 HR INSP-FLOATS									
Comments:												

Trans. Type: 1 - Component, 2 - Inspection, 3 - SB, 4 - AD, - - Misc.

Removal Reasons: WO - Worn to Limits, SC - Scheduled, UN - Unscheduled, CO - Convenience, N - Other(note in comments)

Installed Part Status: N - New, R - Repaired/Rebuilt, S - Serviceable, O - Overhauled

Repair Facility _____	Certified Repair Station Number _____	Work Order No. 160037
Work Performed By MIKE ANGELO MARTINEZ	Certificate No. 112468 AMT	Date 30-Jan-2016
I certify that the above stated maintenance and/or inspection was performed in accordance with the current regulations of the <input type="checkbox"/> Federal Aviation Administration <input checked="" type="checkbox"/> Other (Specify) CAAP _____ and _____		
THE AIRCRAFT IDENTIFIED ABOVE IS PRESENTLY AIRWORTHY AND APPROVED FOR RETURN TO SERVICE.		
Work Inspected By NESTOR DERPO	Certificate No. 119184AMT	Date 30-Jan-2016
Pertinent details of this maintenance are on file at our facility under the above Work/Service Order Number as applicable.		

Maintenance Log	
Book	Page



Maintenance Transaction Record



This Maintenance Report is To Be Used Solely For (Check One)

Airframe Entries Eng. Serial No. _____ Prop. Serial No. _____

CAMP Systems International
8200 E. 34TH STREET
BUILDING 1600, SUITE 1607
Wichita, KS 67226
Phone: 316-462-2267/ Fax: 316-462-0791

Aircraft Identification and Status

A/C Serial #	A/C Unit #	A/C Registration #	Date	City ID	Total A/C Hours	Total A/C Landings	Total Engine Hrs	Total Engine Cycles	Total Prop Hrs			
208B-5098		RP-C1087	19-Jan-2016	MNL	724	901	724	901	724			

Component Changes, Inspections, Service Bulletins, or Airworthiness Directives Accomplished

Item	Transaction No.	Type	Item Name	Position	Part Number / Alternate Part Number	Mod Level	Part Serial	Removal Reason	Installed Part Status	TSN/TSO/TSR	Material Costs	Man Hours
051260	1	2	INSPECT 25 HR INSP-FLOATS									
Comments:												

Trans. Type: 1 - Component, 2 - Inspection, 3 - SB, 4 - AD, - - Misc.

Removal Reasons: WO - Worn to Limits, SC - Scheduled, UN - Unscheduled, CO - Convenience, N - Other(note in comments)

Installed Part Status: N - New, R - Repaired/Rebuilt, S - Serviceable, O - Overhauled

Repair Facility _____ **Certified Repair Station Number** _____ **Work Order No.** 160022
Work Performed By MIKE ANGELO MARTINEZ **Certificate No.** 112468 AMT **Date** 19-Jan-2016
 I certify that the above stated maintenance and/or inspection was performed in accordance with the current regulations of the
 Federal Aviation Administration Other (Specify) CAAP _____ and
 THE AIRCRAFT IDENTIFIED ABOVE IS PRESENTLY AIRWORTHY AND APPROVED FOR RETURN TO SERVICE.
Work Inspected By NESTOR DERPO **Certificate No.** 119184AMT **Date** 19-Jan-2016
 Pertinent details of this maintenance are on file at our facility under the above Work/Service Order Number as applicable.

Maintenance Log	
Book	Page



Maintenance Transaction Record



This Maintenance Report is To Be Used Solely For (Check One)

Airframe Entries Eng. Serial No. _____ Prop. Serial No. _____

CAMP Systems International
8200 E. 34TH STREET
BUILDING 1600, SUITE 1607
Wichita, KS 67226
Phone: 316-462-2267/ Fax: 316-462-0791

Aircraft Identification and Status

A/C Serial #	A/C Unit #	A/C Registration #	Date	City ID	Total A/C Hours	Total A/C Landings	Total Engine Hrs	Total Engine Cycles	Total Prop Hrs			
208B-5098		RP-C1087	12-Jan-2016	MNL	713.9	884	713.9	884	713.9			

Component Changes, Inspections, Service Bulletins, or Airworthiness Directives Accomplished

Item	Transaction No.	Type	Item Name	Position	Part Number / Alternate Part Number	Mod Level	Part Serial	Removal Reason	Installed Part Status	TSN/TSO/TSR	Material Costs	Man Hours
CAL-28-01	1	3	FUEL - INSPECTION / REPLACEMENT OF LEFT LOW FUEL LEVEL SWITCH COVER ASSEMBLY, SERVICE LETTER Comments: NEXT DUE WILL BE NOVEMBER 2016									

Trans. Type: 1 - Component, 2 - Inspection, 3 - SB, 4 - AD, - - Misc.

Removal Reasons: WO - Worn to Limits, SC - Scheduled, UN - Unscheduled, CO - Convenience, N - Other(note in comments)

Installed Part Status: N - New, R - Repaired/Rebuilt, S - Serviceable, O - Overhauled

Repair Facility _____ **Certified Repair Station Number** _____ **Work Order No.** 160011
Work Performed By MIKE ANGELO MARTINEZ **Certificate No.** 112468 AMT **Date** 12-Jan-2016
 I certify that the above stated maintenance and/or inspection was performed in accordance with the current regulations of the
 Federal Aviation Administration Other (Specify) CAAP _____ and
 THE AIRCRAFT IDENTIFIED ABOVE IS PRESENTLY AIRWORTHY AND APPROVED FOR RETURN TO SERVICE.
Work Inspected By DAVE BANARES **Certificate No.** 114533 AMT **Date** 12-Jan-2016
 Pertinent details of this maintenance are on file at our facility under the above Work/Service Order Number as applicable.

Maintenance Log	
Book	Page



Maintenance Transaction Record



This Maintenance Report is To Be Used Solely For (Check One)

Airframe Entries Eng. Serial No. _____ Prop. Serial No. _____

CAMP Systems International
8200 E. 34TH STREET
BUILDING 1600, SUITE 1607
Wichita, KS 67226
Phone: 316-462-2267/ Fax: 316-462-0791

Aircraft Identification and Status

A/C Serial #	A/C Unit #	A/C Registration #	Date	City ID	Total A/C Hours	Total A/C Landings	Total Engine Hrs	Total Engine Cycles	Total Prop Hrs			
208B-5098		RP-C1087	08-Jan-2016	MNL	699.1	863	699.1	863	699.1			

Component Changes, Inspections, Service Bulletins, or Airworthiness Directives Accomplished

Item	Transaction No.	Type	Item Name	Position	Part Number / Alternate Part Number	Mod Level	Part Serial	Removal Reason	Installed Part Status	TSN/TSO/TSR	Material Costs	Man Hours
051260	1	2	INSPECT 25 HR INSP-FLOATS Comments:									
051265	2	2	INSPECT 50 HR INSP-FLOATS Comments:									
5-15-07	3	2	INSPECTION DOCUMENT 07 Comments:									
051270	4	2	INSPECT 100 HR INSP-FLOATS Comments:									
057010	5	2	NO. 1 ENGINE - MINOR INSPECTION Comments:									
731100	6	2	NO. 1 ENGINE - OPERATIONAL CHECK CONTROL MANUAL OVERRIDE STATIC SYSTEM Comments:									
733010	7	2	NO. 1 ENGINE - GENERAL VISUAL INSPECTION PNEUMATIC P3 FILTER DRAIN VALVE Comments:									
741025	8	2	NO. 1 ENGINE - GENERAL VISUAL INSPECTION 4 O Comments:	4 O	CH34055		NSN					

Trans. Type: 1 - Component, 2 - Inspection, 3 - SB, 4 - AD, - - Misc.

Removal Reasons: WO - Worn to Limits, SC - Scheduled, UN - Unscheduled, CO - Convenience, N - Other(note in comments)

Installed Part Status: N - New, R - Repaired/Rebuilt, S - Serviceable, O - Overhauled

Repair Facility _____	Certified Repair Station Number _____	Work Order No. 160010
Work Performed By DAVE BANARES	Certificate No. 114533AMT	Date 08-Jan-2016
I certify that the above stated maintenance and/or inspection was performed in accordance with the current regulations of the <input type="checkbox"/> Federal Aviation Administration <input checked="" type="checkbox"/> Other (Specify) CAAP _____ and THE AIRCRAFT IDENTIFIED ABOVE IS PRESENTLY AIRWORTHY AND APPROVED FOR RETURN TO SERVICE.		
Work Inspected By NESTOR DERPO	Certificate No. 119184AMT	Date 08-Jan-2016
Pertinent details of this maintenance are on file at our facility under the above Work/Service Order Number as applicable.		

Maintenance Log	
Book	Page



Maintenance Transaction Record



This Maintenance Report is To Be Used Solely For (Check One)

Airframe Entries
 Eng. Serial No. _____
 Prop. Serial No. _____

CAMP Systems International
 8200 E. 34TH STREET
 BUILDING 1600, SUITE 1607
 Wichita, KS 67226
 Phone: 316-462-2267/ Fax: 316-462-0791

Aircraft Identification and Status

A/C Serial #	A/C Unit #	A/C Registration #	Date	City ID	Total A/C Hours	Total A/C Landings	Total Engine Hrs	Total Engine Cycles	Total Prop Hrs			
208B-5098		RP-C1087	08-Jan-2016	MNL	699.1	863	699.1	863	699.1			

Component Changes, Inspections, Service Bulletins, or Airworthiness Directives Accomplished

Item	Transaction No.	Type	Item Name	Position	Part Number / Alternate Part Number	Mod Level	Part Serial	Removal Reason	Installed Part Status	TSN/TSO/TSR	Material Costs	Man Hours
741035	9	2	NO. 1 ENGINE - GENERAL VISUAL INSPECTION 9 O	9 O	CH34055		NSN					
Comments:												
761010	10	2	NO. 1 ENGINE - GENERAL VISUAL INSPECTION ENGINE CONTROL LINKAGES AND WIRING									
Comments:												

Trans. Type: 1 - Component, 2 - Inspection, 3 - SB, 4 - AD, - - Misc.

Removal Reasons: WO - Worn to Limits, SC - Scheduled, UN - Unscheduled, CO - Convenience, N - Other(note in comments)

Installed Part Status: N - New, R - Repaired/Rebuilt, S - Serviceable, O - Overhauled

Repair Facility _____	Certified Repair Station Number _____	Work Order No. 160010
Work Performed By DAVE BANARES	Certificate No. 114533AMT	Date 08-Jan-2016
I certify that the above stated maintenance and/or inspection was performed in accordance with the current regulations of the <input type="checkbox"/> Federal Aviation Administration <input checked="" type="checkbox"/> Other (Specify) CAAP _____ and _____		
THE AIRCRAFT IDENTIFIED ABOVE IS PRESENTLY AIRWORTHY AND APPROVED FOR RETURN TO SERVICE.		
Work Inspected By NESTOR DERPO	Certificate No. 119184AMT	Date 08-Jan-2016
Pertinent details of this maintenance are on file at our facility under the above Work/Service Order Number as applicable.		

Maintenance Log	
Book	Page



Maintenance Transaction Record



This Maintenance Report is To Be Used Solely For (Check One)

Airframe Entries
 Eng. Serial No. _____
 Prop. Serial No. _____

CAMP Systems International
 8200 E. 34TH STREET
 BUILDING 1600, SUITE 1607
 Wichita, KS 67226
 Phone: 316-462-2267/ Fax: 316-462-0791

Aircraft Identification and Status

A/C Serial #	A/C Unit #	A/C Registration #	Date	City ID	Total A/C Hours	Total A/C Landings	Total Engine Hrs	Total Engine Cycles	Total Prop Hrs			
208B-5098		RP-C1087	05-Jan-2016	MNL	687.6	842	687.6	842	687.6			

Component Changes, Inspections, Service Bulletins, or Airworthiness Directives Accomplished

Item	Transaction No.	Type	Item Name	Position	Part Number / Alternate Part Number	Mod Level	Part Serial	Removal Reason	Installed Part Status	TSN/TSO/TSR	Material Costs	Man Hours
340022	1	1	RIGHT ATTITUDE GYRO	RIGHT	1U149-015-15		T96687Q	UN	O			
Comments: Removed part no: 1U149-015-15 Removed serial no: T102848R.												

Trans. Type: 1 - Component, 2 - Inspection, 3 - SB, 4 - AD, - - Misc.

Removal Reasons: WO - Worn to Limits, SC - Scheduled, UN - Unscheduled, CO - Convenience, N - Other(note in comments)

Installed Part Status: N - New, R - Repaired/Rebuilt, S - Serviceable, O - Overhauled

Repair Facility _____ Certified Repair Station Number _____ Work Order No. 160007 Work Performed By ROMEO LERIOS Certificate No. 112167AMS Date 05-Jan-2016 I certify that the above stated maintenance and/or inspection was performed in accordance with the current regulations of the <input type="checkbox"/> Federal Aviation Administration <input checked="" type="checkbox"/> Other (Specify) CAAP _____ and _____ THE AIRCRAFT IDENTIFIED ABOVE IS PRESENTLY AIRWORTHY AND APPROVED FOR RETURN TO SERVICE. Work Inspected By NESTOR DERPO Certificate No. 119184AMT Date 05-Jan-2016 Pertinent details of this maintenance are on file at our facility under the above Work/Service Order Number as applicable.

Maintenance Log	
Book	Page



Maintenance Transaction Record



This Maintenance Report is To Be Used Solely For (Check One)

Airframe Entries
 Eng. Serial No. _____
 Prop. Serial No. _____

CAMP Systems International
 8200 E. 34TH STREET
 BUILDING 1600, SUITE 1607
 Wichita, KS 67226
 Phone: 316-462-2267/ Fax: 316-462-0791

Aircraft Identification and Status

A/C Serial #	A/C Unit #	A/C Registration #	Date	City ID	Total A/C Hours	Total A/C Landings	Total Engine Hrs	Total Engine Cycles	Total Prop Hrs			
208B-5098		RP-C1087	01-Jan-2016	MNL	674.8	827	674.8	827	674.8			

Component Changes, Inspections, Service Bulletins, or Airworthiness Directives Accomplished

Item	Transaction No.	Type	Item Name	Position	Part Number / Alternate Part Number	Mod Level	Part Serial	Removal Reason	Installed Part Status	TSN/TSO/TSR	Material Costs	Man Hours
051260	1	2	INSPECT 25 HR INSP-FLOATS									
Comments:												

Trans. Type: 1 - Component, 2 - Inspection, 3 - SB, 4 - AD, - - Misc.

Removal Reasons: WO - Worn to Limits, SC - Scheduled, UN - Unscheduled, CO - Convenience, N - Other(note in comments)

Installed Part Status: N - New, R - Repaired/Rebuilt, S - Serviceable, O - Overhauled

Repair Facility _____	Certified Repair Station Number _____	Work Order No. 151249
Work Performed By MIKE ANGELO MARTINEZ	Certificate No. 112468 AMT	Date 01-Jan-2016
I certify that the above stated maintenance and/or inspection was performed in accordance with the current regulations of the <input type="checkbox"/> Federal Aviation Administration <input checked="" type="checkbox"/> Other (Specify) CAAP _____ and _____		
THE AIRCRAFT IDENTIFIED ABOVE IS PRESENTLY AIRWORTHY AND APPROVED FOR RETURN TO SERVICE.		
Work Inspected By NESTOR DERPO	Certificate No. 119184AMT	Date 01-Jan-2016
Pertinent details of this maintenance are on file at our facility under the above Work/Service Order Number as applicable.		

Maintenance Log	
Book	Page



Maintenance Transaction Record



This Maintenance Report is To Be Used Solely For (Check One)

Airframe Entries
 Eng. Serial No. _____
 Prop. Serial No. _____

CAMP Systems International
 8200 E. 34TH STREET
 BUILDING 1600, SUITE 1607
 Wichita, KS 67226
 Phone: 316-462-2267/ Fax: 316-462-0791

Aircraft Identification and Status

A/C Serial #	A/C Unit #	A/C Registration #	Date	City ID	Total A/C Hours	Total A/C Landings	Total Engine Hrs	Total Engine Cycles	Total Prop Hrs			
208B-5098		RP-C1087	23-Dec-2015	MNL	625.2	761	625.2	761	625.2			

Component Changes, Inspections, Service Bulletins, or Airworthiness Directives Accomplished

Item	Transaction No.	Type	Item Name	Position	Part Number / Alternate Part Number	Mod Level	Part Serial	Removal Reason	Installed Part Status	TSN/TSO/TSR	Material Costs	Man Hours
780201	1	1	SECONDARY EXHAUST DUCT ASSEMBLY		2654008-205		NSN	UN	S			
Comments: Removed part no: 2654030-18 Removed serial no: TRI-13-1031. FROM RP-C 1780												
051260	2	2	INSPECT 25 HR INSP-FLOATS									
Comments:												

Trans. Type: 1 - Component, 2 - Inspection, 3 - SB, 4 - AD, - - Misc.

Removal Reasons: WO - Worn to Limits, SC - Scheduled, UN - Unscheduled, CO - Convenience, N - Other(note in comments)

Installed Part Status: N - New, R - Repaired/Rebuilt, S - Serviceable, O - Overhauled

Repair Facility _____ Certified Repair Station Number _____ Work Order No. 151236 Work Performed By CHAZ MICHAEL C DATU Certificate No. 126124AMT Date 23-Dec-2015 I certify that the above stated maintenance and/or inspection was performed in accordance with the current regulations of the <input type="checkbox"/> Federal Aviation Administration <input checked="" type="checkbox"/> Other (Specify) CAAP _____ and THE AIRCRAFT IDENTIFIED ABOVE IS PRESENTLY AIRWORTHY AND APPROVED FOR RETURN TO SERVICE. Work Inspected By NESTOR DERPO Certificate No. 119184AMT Date 23-Dec-2015 Pertinent details of this maintenance are on file at our facility under the above Work/Service Order Number as applicable.
--

Maintenance Log	
Book	Page



Maintenance Transaction Record



This Maintenance Report is To Be Used Solely For (Check One)

Airframe Entries
 Eng. Serial No. _____
 Prop. Serial No. _____

CAMP Systems International
 8200 E. 34TH STREET
 BUILDING 1600, SUITE 1607
 Wichita, KS 67226
 Phone: 316-462-2267/ Fax: 316-462-0791

Aircraft Identification and Status

A/C Serial #	A/C Unit #	A/C Registration #	Date	City ID	Total A/C Hours	Total A/C Landings	Total Engine Hrs	Total Engine Cycles	Total Prop Hrs			
208B-5098		RP-C1087	23-Dec-2015	MNL	604.1	732	604.1	732	604.1			

Component Changes, Inspections, Service Bulletins, or Airworthiness Directives Accomplished

Item	Transaction No.	Type	Item Name	Position	Part Number / Alternate Part Number	Mod Level	Part Serial	Removal Reason	Installed Part Status	TSN/TSO/TSR	Material Costs	Man Hours
725040	1	2	NO. 1 ENGINE - GENERAL VISUAL INSPECTION ENGINE EXHAUST DUCT FOR CRACKS									
Comments:												
725040	2	2	NO. 1 ENGINE - GENERAL VISUAL INSPECTION ENGINE EXHAUST DUCT FOR CRACKS									
Comments:												
051275	3	2	INSPECT 200 HR INSP-FLOATS									
Comments:												
051275	4	2	INSPECT 200 HR INSP-FLOATS									
Comments:												
051270	5	2	INSPECT 100 HR INSP-FLOATS									
Comments:												
051265	6	2	INSPECT 50 HR INSP-FLOATS									
Comments:												
051265	7	2	INSPECT 50 HR INSP-FLOATS									
Comments:												
051260	8	2	INSPECT 25 HR INSP-FLOATS									
Comments:												
5-15-06	9	2	INSPECTION DOCUMENT 06									

Trans. Type: 1 - Component, 2 - Inspection, 3 - SB, 4 - AD, - - Misc.

Removal Reasons: WO - Worn to Limits, SC - Scheduled, UN - Unscheduled, CO - Convenience, N - Other(note in comments)

Installed Part Status: N - New, R - Repaired/Rebuilt, S - Serviceable, O - Overhauled

Repair Facility _____	Certified Repair Station Number _____	Work Order No. 151237
Work Performed By DAVE BANARES	Certificate No. 114533AMT	Date 23-Dec-2015
I certify that the above stated maintenance and/or inspection was performed in accordance with the current regulations of the <input type="checkbox"/> Federal Aviation Administration <input checked="" type="checkbox"/> Other (Specify) CAAP _____ and THE AIRCRAFT IDENTIFIED ABOVE IS PRESENTLY AIRWORTHY AND APPROVED FOR RETURN TO SERVICE.		
Work Inspected By NESTOR DERPO	Certificate No. 119184AMT	Date 23-Dec-2015
Pertinent details of this maintenance are on file at our facility under the above Work/Service Order Number as applicable.		

Maintenance Log	
Book	Page



Maintenance Transaction Record



This Maintenance Report is To Be Used Solely For (Check One)

Airframe Entries
 Eng. Serial No. _____
 Prop. Serial No. _____

CAMP Systems International
 8200 E. 34TH STREET
 BUILDING 1600, SUITE 1607
 Wichita, KS 67226
 Phone: 316-462-2267/ Fax: 316-462-0791

Aircraft Identification and Status

A/C Serial #	A/C Unit #	A/C Registration #	Date	City ID	Total A/C Hours	Total A/C Landings	Total Engine Hrs	Total Engine Cycles	Total Prop Hrs			
208B-5098		RP-C1087	23-Dec-2015	MNL	604.1	732	604.1	732	604.1			

Component Changes, Inspections, Service Bulletins, or Airworthiness Directives Accomplished

Item	Transaction No.	Type	Item Name	Position	Part Number / Alternate Part Number	Mod Level	Part Serial	Removal Reason	Installed Part Status	TSN/TSO/TSR	Material Costs	Man Hours
Comments:												
614010	10	2	NO. 1 PROPELLER - INSPECT PROPELLER									
Comments:												
731030	11	2	NO. 1 ENGINE - REPLACE FUEL PUMP OUTLET FILTER		3040760		012610					
Comments:												
731040	12	2	NO. 1 ENGINE - GENERAL VISUAL INSPECTION FUEL PUMP INLET SCREEN		3040760		012610					
Comments:												
733020	13	2	NO. 1 ENGINE - CLEAN/REPLACE PNEUMATIC P3 FILTER DEPENDING ON CONDITION									
Comments:												
750020	14	2	NO. 1 ENGINE - GENERAL VISUAL INSPECTION COMPRESSOR BLEED VALVE BLEED VALVE		3049038-03		7819					
Comments:												
790060	15	2	NO. 1 ENGINE - INSPECT AND CLEAN OIL FILTER ELEMENT FOR DEBRIS									
Comments:												
790070	16	2	NO. 1 ENGINE - GENERAL VISUAL INSPECTION AGB INTERNAL SCAVENGE OIL PUMP INLET SCREEN									

Trans. Type: 1 - Component, 2 - Inspection, 3 - SB, 4 - AD, - - Misc.

Removal Reasons: WO - Worn to Limits, SC - Scheduled, UN - Unscheduled, CO - Convenience, N - Other(note in comments)

Installed Part Status: N - New, R - Repaired/Rebuilt, S - Serviceable, O - Overhauled

Repair Facility _____	Certified Repair Station Number _____	Work Order No. 151237
Work Performed By DAVE BANARES	Certificate No. 114533AMT	Date 23-Dec-2015
I certify that the above stated maintenance and/or inspection was performed in accordance with the current regulations of the <input type="checkbox"/> Federal Aviation Administration <input checked="" type="checkbox"/> Other (Specify) CAAP _____ and THE AIRCRAFT IDENTIFIED ABOVE IS PRESENTLY AIRWORTHY AND APPROVED FOR RETURN TO SERVICE.		
Work Inspected By NESTOR DERPO	Certificate No. 119184AMT	Date 23-Dec-2015
Pertinent details of this maintenance are on file at our facility under the above Work/Service Order Number as applicable.		

Maintenance Log	
Book	Page



Maintenance Transaction Record



This Maintenance Report is To Be Used Solely For (Check One)

Airframe Entries
 Eng. Serial No. _____
 Prop. Serial No. _____

CAMP Systems International
 8200 E. 34TH STREET
 BUILDING 1600, SUITE 1607
 Wichita, KS 67226
 Phone: 316-462-2267/ Fax: 316-462-0791

Aircraft Identification and Status

A/C Serial #	A/C Unit #	A/C Registration #	Date	City ID	Total A/C Hours	Total A/C Landings	Total Engine Hrs	Total Engine Cycles	Total Prop Hrs			
208B-5098		RP-C1087	23-Dec-2015	MNL	604.1	732	604.1	732	604.1			

Component Changes, Inspections, Service Bulletins, or Airworthiness Directives Accomplished

Item	Transaction No. Type	Item Name	Position	Part Number / Alternate Part Number	Mod Level	Part Serial	Removal Reason	InstalledPart Status TSN/TSO/TSR	Material Costs	Man Hours
790090	17 2	NO. 1 ENGINE - GENERAL VISUAL INSPECTION CHIP DETECTOR FOR DEBRIS								
Comments:										

Trans. Type: 1 - Component, 2 - Inspection, 3 - SB, 4 - AD, - - Misc.

Removal Reasons: WO - Worn to Limits, SC - Scheduled, UN - Unscheduled, CO - Convenience, N - Other(note in comments)

Installed Part Status: N - New, R - Repaired/Rebuilt, S - Serviceable, O - Overhauled

Repair Facility _____ **Certified Repair Station Number** _____ **Work Order No.** 151237

Work Performed By DAVE BANARES **Certificate No.** 114533AMT **Date** 23-Dec-2015

I certify that the above stated maintenance and/or inspection was performed in accordance with the current regulations of the
 Federal Aviation Administration
 Other (Specify) CAAP _____ and _____

THE AIRCRAFT IDENTIFIED ABOVE IS PRESENTLY AIRWORTHY AND APPROVED FOR RETURN TO SERVICE.

Work Inspected By NESTOR DERPO **Certificate No.** 119184AMT **Date** 23-Dec-2015

Pertinent details of this maintenance are on file at our facility under the above Work/Service Order Number as applicable.

Maintenance Log	
Book	Page



Maintenance Transaction Record



This Maintenance Report is To Be Used Solely For (Check One)

Airframe Entries
 Eng. Serial No. _____
 Prop. Serial No. _____

CAMP Systems International
 8200 E. 34TH STREET
 BUILDING 1600, SUITE 1607
 Wichita, KS 67226
 Phone: 316-462-2267/ Fax: 316-462-0791

Aircraft Identification and Status

A/C Serial #	A/C Unit #	A/C Registration #	Date	City ID	Total A/C Hours	Total A/C Landings	Total Engine Hrs	Total Engine Cycles	Total Prop Hrs			
208B-5098		RP-C1087	06-Dec-2015	MNL	574.5	693	574.5	693	574.5			

Component Changes, Inspections, Service Bulletins, or Airworthiness Directives Accomplished

Item	Transaction No.	Type	Item Name	Position	Part Number / Alternate Part Number	Mod Level	Part Serial	Removal Reason	Installed Part Status	TSN/TSO/TSR	Material Costs	Man Hours
051260	1	2	INSPECT 25 HR INSP-FLOATS									
Comments:												

Trans. Type: 1 - Component, 2 - Inspection, 3 - SB, 4 - AD, - - Misc.

Removal Reasons: WO - Worn to Limits, SC - Scheduled, UN - Unscheduled, CO - Convenience, N - Other(note in comments)

Installed Part Status: N - New, R - Repaired/Rebuilt, S - Serviceable, O - Overhauled

Repair Facility _____	Certified Repair Station Number _____	Work Order No. 151251
Work Performed By DAVE BANARES	Certificate No. 114533AMT	Date 06-Dec-2015
I certify that the above stated maintenance and/or inspection was performed in accordance with the current regulations of the <input type="checkbox"/> Federal Aviation Administration <input checked="" type="checkbox"/> Other (Specify) CAAP _____ and _____		
THE AIRCRAFT IDENTIFIED ABOVE IS PRESENTLY AIRWORTHY AND APPROVED FOR RETURN TO SERVICE.		
Work Inspected By NESTOR DERPO	Certificate No. 119184AMT	Date 06-Dec-2015
Pertinent details of this maintenance are on file at our facility under the above Work/Service Order Number as applicable.		

Maintenance Log	
Book	Page



Maintenance Transaction Record



This Maintenance Report is To Be Used Solely For (Check One)

Airframe Entries
 Eng. Serial No. _____
 Prop. Serial No. _____

CAMP Systems International
 8200 E. 34TH STREET
 BUILDING 1600, SUITE 1607
 Wichita, KS 67226
 Phone: 316-462-2267/ Fax: 316-462-0791

Aircraft Identification and Status

A/C Serial #	A/C Unit #	A/C Registration #	Date	City ID	Total A/C Hours	Total A/C Landings	Total Engine Hrs	Total Engine Cycles	Total Prop Hrs			
208B-5098		RP-C1087	29-Nov-2015	MNL	548.6	648	548.6	648	548.6			

Component Changes, Inspections, Service Bulletins, or Airworthiness Directives Accomplished

Item	Transaction No.	Type	Item Name	Position	Part Number / Alternate Part Number	Mod Level	Part Serial	Removal Reason	Installed Part Status	TSN/TSO/TSR	Material Costs	Man Hours
051260	1	2	INSPECT 25 HR INSP-FLOATS									
Comments:												
051265	2	2	INSPECT 50 HR INSP-FLOATS									
Comments:												

Trans. Type: 1 - Component, 2 - Inspection, 3 - SB, 4 - AD, - - Misc.

Removal Reasons: WO - Worn to Limits, SC - Scheduled, UN - Unscheduled, CO - Convenience, N - Other(note in comments)

Installed Part Status: N - New, R - Repaired/Rebuilt, S - Serviceable, O - Overhauled

Repair Facility _____ Certified Repair Station Number _____ Work Order No. 151238 Work Performed By DAVE BANARES Certificate No. 114533AMT Date 29-Nov-2015 I certify that the above stated maintenance and/or inspection was performed in accordance with the current regulations of the <input type="checkbox"/> Federal Aviation Administration <input checked="" type="checkbox"/> Other (Specify) CAAP _____ and _____ THE AIRCRAFT IDENTIFIED ABOVE IS PRESENTLY AIRWORTHY AND APPROVED FOR RETURN TO SERVICE. Work Inspected By NESTOR DERPO Certificate No. 119184AMT Date 29-Nov-2015 Pertinent details of this maintenance are on file at our facility under the above Work/Service Order Number as applicable.

Maintenance Log	
Book	Page



Maintenance Transaction Record



This Maintenance Report is To Be Used Solely For (Check One)

Airframe Entries
 Eng. Serial No. _____
 Prop. Serial No. _____

CAMP Systems International
 8200 E. 34TH STREET
 BUILDING 1600, SUITE 1607
 Wichita, KS 67226
 Phone: 316-462-2267/ Fax: 316-462-0791

Aircraft Identification and Status

A/C Serial #	A/C Unit #	A/C Registration #	Date	City ID	Total A/C Hours	Total A/C Landings	Total Engine Hrs	Total Engine Cycles	Total Prop Hrs			
208B-5098		RP-C1087	25-Nov-2015	MNL	532.5	626	532.5	626	532.5			

Component Changes, Inspections, Service Bulletins, or Airworthiness Directives Accomplished

Item	Transaction No.	Type	Item Name	Position	Part Number / Alternate Part Number	Mod Level	Part Serial	Removal Reason	Installed Part Status	TSN/TSO/TSR	Material Costs	Man Hours
321110F 321110F : LI	1	1	LEFT INBOARD BRAKE BACK PLATE	LEFT INBOARD	PN07302900		NSN	WO	N	0 MTH 0 HRS		
Comments: Removed part no: PN07302900 Removed serial no: NSN.												
321108F	2	1	LEFT INBOARD BRAKE DISC	LEFT INBOARD			NSN	UN	N	0 MTH 0 HRS		
Comments: Removed part no: PN Removed serial no: SN-UNKNOWN.												
321106F 321106F : LI	3	1	LEFT INBOARD BRAKE PRESSURE PLATE	LEFT INBOARD	PN073-04200		NSN	UN	N	0 MTH 0 HRS		
Comments: Removed part no: PN073-04200 Removed serial no: NSN.												

Trans. Type: 1 - Component, 2 - Inspection, 3 - SB, 4 - AD, - - Misc.

Removal Reasons: WO - Worn to Limits, SC - Scheduled, UN - Unscheduled, CO - Convenience, N - Other(note in comments)

Installed Part Status: N - New, R - Repaired/Rebuilt, S - Serviceable, O - Overhauled

Repair Facility _____	Certified Repair Station Number _____	Work Order No. 151229
Work Performed By CHAZ MICHAEL C DATU	Certificate No. 126124AMT	Date 25-Nov-2015
I certify that the above stated maintenance and/or inspection was performed in accordance with the current regulations of the <input type="checkbox"/> Federal Aviation Administration <input checked="" type="checkbox"/> Other (Specify) CAAP _____ and THE AIRCRAFT IDENTIFIED ABOVE IS PRESENTLY AIRWORTHY AND APPROVED FOR RETURN TO SERVICE.		
Work Inspected By NES	Certificate No. _____	Date 25-Nov-2015
Pertinent details of this maintenance are on file at our facility under the above Work/Service Order Number as applicable.		

Maintenance Log	
Book	Page



Maintenance Transaction Record



This Maintenance Report is To Be Used Solely For (Check One)

Airframe Entries Eng. Serial No. _____ Prop. Serial No. _____

CAMP Systems International
8200 E. 34TH STREET
BUILDING 1600, SUITE 1607
Wichita, KS 67226
Phone: 316-462-2267/ Fax: 316-462-0791

Aircraft Identification and Status

A/C Serial #	A/C Unit #	A/C Registration #	Date	City ID	Total A/C Hours	Total A/C Landings	Total Engine Hrs	Total Engine Cycles	Total Prop Hrs			
208B-5098		RP-C1087	23-Nov-2015	MNL	527.7	620	527.7	620	527.7			

Component Changes, Inspections, Service Bulletins, or Airworthiness Directives Accomplished

Item	Transaction No.	Type	Item Name	Position	Part Number / Alternate Part Number	Mod Level	Part Serial	Removal Reason	Installed Part Status	TSN/TSO/TSR	Material Costs	Man Hours
051260	1	2	INSPECT 25 HR INSP-FLOATS Comments:									
320301F	2	1	RIGHT OUTBOARD (FLOAT) TIRE Comments: Removed part no: AA1E6 Removed serial no: AIE6-1615.	RIGHT OUTBOARD	A1E6	6.00X6 8PLY	AIE61615	WO	N	0 MTH 0 HRS		
321108F	3	1	RIGHT INBOARD BRAKE DISC Comments: Removed part no: 164-24500 Removed serial no: NSN.	RIGHT INBOARD	164-24500		NSN	WO	N	0 MTH 0 HRS		
321108F	4	1	RIGHT OUTBOARD BRAKE DISC Comments: Removed part no: PN Removed serial no: SN-UNKNOWN.	RIGHT OUTBOARD			NSN	WO	N	0 MTH 0 HRS		

Trans. Type: 1 - Component, 2 - Inspection, 3 - SB, 4 - AD, - - Misc.

Removal Reasons: WO - Worn to Limits, SC - Scheduled, UN - Unscheduled, CO - Convenience, N - Other(note in comments)

Installed Part Status: N - New, R - Repaired/Rebuilt, S - Serviceable, O - Overhauled

Repair Facility _____ Certified Repair Station Number _____ Work Order No. 151225

Work Performed By DAVE BANARES Certificate No. 114533AMT Date 23-Nov-2015

I certify that the above stated maintenance and/or inspection was performed in accordance with the current regulations of the
 Federal Aviation Administration Other (Specify) CAAP _____ and _____

THE AIRCRAFT IDENTIFIED ABOVE IS PRESENTLY AIRWORTHY AND APPROVED FOR RETURN TO SERVICE.

Work Inspected By NESTOR DERPO Certificate No. 119184AMT Date 23-Nov-2015

Pertinent details of this maintenance are on file at our facility under the above Work/Service Order Number as applicable.

Maintenance Log	
Book	Page



Maintenance Transaction Record



This Maintenance Report is To Be Used Solely For (Check One)

Airframe Entries Eng. Serial No. _____ Prop. Serial No. _____

CAMP Systems International
8200 E. 34TH STREET
BUILDING 1600, SUITE 1607
Wichita, KS 67226
Phone: 316-462-2267/ Fax: 316-462-0791

Aircraft Identification and Status

A/C Serial #	A/C Unit #	A/C Registration #	Date	City ID	Total A/C Hours	Total A/C Landings	Total Engine Hrs	Total Engine Cycles	Total Prop Hrs			
208B-5098		RP-C1087	30-Oct-2015	MNL	499.2	580	499.2	580	499.2			

Component Changes, Inspections, Service Bulletins, or Airworthiness Directives Accomplished

Item	Transaction No.	Type	Item Name	Position	Part Number / Alternate Part Number	Mod Level	Part Serial	Removal Reason	Installed Part Status	TSN/TSO/TSR	Material Costs	Man Hours
057010	1	2	NO. 1 ENGINE - MINOR INSPECTION									
Comments:												
733010	2	2	NO. 1 ENGINE - GENERAL VISUAL INSPECTION PNEUMATIC P3 FILTER DRAIN VALVE									
Comments:												
741025	3	2	NO. 1 ENGINE - GENERAL VISUAL INSPECTION 4 O	4 O	CH34055		NSN					
Comments:												
741035	4	2	NO. 1 ENGINE - GENERAL VISUAL INSPECTION 9 O	9 O	CH34055		NSN					
Comments:												
761010	5	2	NO. 1 ENGINE - GENERAL VISUAL INSPECTION ENGINE CONTROL LINKAGES AND WIRING									
Comments:												
051280	6	2	INSPECTION ANNUAL FLOAT									
Comments:												
051270	7	2	INSPECT 100 HR INSP-FLOATS									
Comments:												
790060	8	2	NO. 1 ENGINE - INSPECT OIL FILTER ELEMENT FOR DEBRIS									

Trans. Type: 1 - Component, 2 - Inspection, 3 - SB, 4 - AD, - - Misc.

Removal Reasons: WO - Worn to Limits, SC - Scheduled, UN - Unscheduled, CO - Convenience, N - Other(note in comments)

Installed Part Status: N - New, R - Repaired/Rebuilt, S - Serviceable, O - Overhauled

Repair Facility _____	Certified Repair Station Number _____	Work Order No. 151200
Work Performed By DAVE BANARES	Certificate No. 114533AMT	Date 30-Oct-2015
I certify that the above stated maintenance and/or inspection was performed in accordance with the current regulations of the		
<input type="checkbox"/> Federal Aviation Administration <input checked="" type="checkbox"/> Other (Specify) CAAP _____ and		
THE AIRCRAFT IDENTIFIED ABOVE IS PRESENTLY AIRWORTHY AND APPROVED FOR RETURN TO SERVICE.		
Work Inspected By NESTOR DERPO	Certificate No. 119184AMT	Date 02-Nov-2015
Pertinent details of this maintenance are on file at our facility under the above Work/Service Order Number as applicable.		

Maintenance Log	
Book	Page



Maintenance Transaction Record



This Maintenance Report is To Be Used Solely For (Check One)

Airframe Entries Eng. Serial No. _____ Prop. Serial No. _____

CAMP Systems International
8200 E. 34TH STREET
BUILDING 1600, SUITE 1607
Wichita, KS 67226
Phone: 316-462-2267/ Fax: 316-462-0791

Aircraft Identification and Status

A/C Serial #	A/C Unit #	A/C Registration #	Date	City ID	Total A/C Hours	Total A/C Landings	Total Engine Hrs	Total Engine Cycles	Total Prop Hrs			
208B-5098		RP-C1087	30-Oct-2015	MNL	499.2	580	499.2	580	499.2			

Component Changes, Inspections, Service Bulletins, or Airworthiness Directives Accomplished

Item	Transaction No. Type	Item Name	Position	Part Number / Alternate Part Number	Mod Level	Part Serial	Removal Reason	Installed Part Status TSN/TSO/TSR	Material Costs	Man Hours
Comments:										
790090	9 2	NO. 1 ENGINE - GENERAL VISUAL INSPECTION CHIP DETECTOR FOR DEBRIS								
Comments:										
733020	10 2	NO. 1 ENGINE - CLEAN/REPLACE PNEUMATIC P3 FILTER DEPENDING ON CONDITION								
Comments:										
725050	11 2	NO. 1 ENGINE - GENERAL VISUAL INSPECTION ENGINE EXHAUST DUCT WELDS								
Comments:										
731100	12 2	NO. 1 ENGINE - OPERATIONAL CHECK CONTROL MANUAL OVERRIDE STATIC SYSTEM								
Comments:										

Trans. Type: 1 - Component, 2 - Inspection, 3 - SB, 4 - AD, - - Misc.

Removal Reasons: WO - Worn to Limits, SC - Scheduled, UN - Unscheduled, CO - Convenience, N - Other(note in comments)

Installed Part Status: N - New, R - Repaired/Rebuilt, S - Serviceable, O - Overhauled

Repair Facility _____	Certified Repair Station Number _____	Work Order No. 151200
Work Performed By DAVE BANARES	Certificate No. 114533AMT	Date 30-Oct-2015
I certify that the above stated maintenance and/or inspection was performed in accordance with the current regulations of the <input type="checkbox"/> Federal Aviation Administration <input checked="" type="checkbox"/> Other (Specify) CAAP _____ and THE AIRCRAFT IDENTIFIED ABOVE IS PRESENTLY AIRWORTHY AND APPROVED FOR RETURN TO SERVICE.		
Work Inspected By NESTOR DERPO	Certificate No. 119184AMT	Date 02-Nov-2015
Pertinent details of this maintenance are on file at our facility under the above Work/Service Order Number as applicable.		

Maintenance Log	
Book	Page



Maintenance Transaction Record



This Maintenance Report is To Be Used Solely For (Check One)

Airframe Entries Eng. Serial No. _____ Prop. Serial No. _____

CAMP Systems International
8200 E. 34TH STREET
BUILDING 1600, SUITE 1607
Wichita, KS 67226
Phone: 316-462-2267/ Fax: 316-462-0791

Aircraft Identification and Status

A/C Serial #	A/C Unit #	A/C Registration #	Date	City ID	Total A/C Hours	Total A/C Landings	Total Engine Hrs	Total Engine Cycles	Total Prop Hrs			
208B-5098		RP-C1087	22-Sep-2015	MNL	479.5	555	479.5	555	479.5			

Component Changes, Inspections, Service Bulletins, or Airworthiness Directives Accomplished

Item	Transaction No.	Type	Item Name	Position	Part Number / Alternate Part Number	Mod Level	Part Serial	Removal Reason	Installed Part Status	TSN/TSO/TSR	Material Costs	Man Hours
CAB-55-01	1	3	STABILIZERS - INSPECTION / MODIFICATION OF GAP BETWEEN VERTICAL FORWARD SPAR CAPS AND CANTED BULKHEAD, SERVICE BULLETIN									
Comments:												

Trans. Type: 1 - Component, 2 - Inspection, 3 - SB, 4 - AD, - - Misc.

Removal Reasons: WO - Worn to Limits, SC - Scheduled, UN - Unscheduled, CO - Convenience, N - Other(note in comments)

Installed Part Status: N - New, R - Repaired/Rebuilt, S - Serviceable, O - Overhauled

Repair Facility _____	Certified Repair Station Number _____	Work Order No. 15153
Work Performed By DAVE BANARES	Certificate No. 114533AMT	Date 22-Sep-2015
I certify that the above stated maintenance and/or inspection was performed in accordance with the current regulations of the <input type="checkbox"/> Federal Aviation Administration <input checked="" type="checkbox"/> Other (Specify) CAAP _____ and THE AIRCRAFT IDENTIFIED ABOVE IS PRESENTLY AIRWORTHY AND APPROVED FOR RETURN TO SERVICE.		
Work Inspected By NESTOR DERPO	Certificate No. 119184AMT	Date 22-Sep-2015
Pertinent details of this maintenance are on file at our facility under the above Work/Service Order Number as applicable.		

Maintenance Log	
Book	Page



Maintenance Transaction Record



This Maintenance Report is To Be Used Solely For (Check One)

Airframe Entries
 Eng. Serial No. _____
 Prop. Serial No. _____

CAMP Systems International
 8200 E. 34TH STREET
 BUILDING 1600, SUITE 1607
 Wichita, KS 67226
 Phone: 316-462-2267/ Fax: 316-462-0791

Aircraft Identification and Status

A/C Serial #	A/C Unit #	A/C Registration #	Date	City ID	Total A/C Hours	Total A/C Landings	Total Engine Hrs	Total Engine Cycles	Total Prop Hrs			
208B-5098		RP-C1087	14-Sep-2015	MNL	476.4	549	476.4	549	476.4			

Component Changes, Inspections, Service Bulletins, or Airworthiness Directives Accomplished

Item	Transaction No.	Type	Item Name	Position	Part Number / Alternate Part Number	Mod Level	Part Serial	Removal Reason	Installed Part Status	TSN/TSO/TSR	Material Costs	Man Hours
5-15-20	1	2	INSPECTION DOCUMENT 20 Comments: DONE BY HAWKER									
5-15-22	2	2	INSPECTION DOCUMENT 22 Comments: DONE BY HAWKER									

Trans. Type: 1 - Component, 2 - Inspection, 3 - SB, 4 - AD, - - Misc.

Removal Reasons: WO - Worn to Limits, SC - Scheduled, UN - Unscheduled, CO - Convenience, N - Other(note in comments)

Installed Part Status: N - New, R - Repaired/Rebuilt, S - Serviceable, O - Overhauled

Repair Facility _____ Certified Repair Station Number _____ Work Order No. 15138 Work Performed By CHAZ MICHAEL C DATU Certificate No. 126124AMT Date 14-Sep-2015 I certify that the above stated maintenance and/or inspection was performed in accordance with the current regulations of the <input type="checkbox"/> Federal Aviation Administration <input checked="" type="checkbox"/> Other (Specify) CAAP _____ and _____ THE AIRCRAFT IDENTIFIED ABOVE IS PRESENTLY AIRWORTHY AND APPROVED FOR RETURN TO SERVICE. Work Inspected By NESTOR DERPO Certificate No. 119184AMT Date 14-Sep-2015 Pertinent details of this maintenance are on file at our facility under the above Work/Service Order Number as applicable.

Maintenance Log	
Book	Page



Maintenance Transaction Record



This Maintenance Report is To Be Used Solely For (Check One)

Airframe Entries Eng. Serial No. _____ Prop. Serial No. _____

CAMP Systems International
8200 E. 34TH STREET
BUILDING 1600, SUITE 1607
Wichita, KS 67226
Phone: 316-462-2267/ Fax: 316-462-0791

Aircraft Identification and Status

A/C Serial #	A/C Unit #	A/C Registration #	Date	City ID	Total A/C Hours	Total A/C Landings	Total Engine Hrs	Total Engine Cycles	Total Prop Hrs			
208B-5098		RP-C1087	14-Sep-2015	MNL	476.4	549	476.4	549	476.4			

Component Changes, Inspections, Service Bulletins, or Airworthiness Directives Accomplished

Item	Transaction No.	Type	Item Name	Position	Part Number / Alternate Part Number	Mod Level	Part Serial	Removal Reason	Installed Part Status	TSN/TSO/TSR	Material Costs	Man Hours
320301F	1	1	RIGHT OUTBOARD (FLOAT) TIRE	RIGHT OUTBOARD	AA1E6	6:00X6 8PLY	AIE6-1615	WO	N	0 MTH 0 HRS		
Comments: Removed part no: AA1E6 Removed serial no: SN-UNKNOWN.												

Trans. Type: 1 - Component, 2 - Inspection, 3 - SB, 4 - AD, - - Misc.

Removal Reasons: WO - Worn to Limits, SC - Scheduled, UN - Unscheduled, CO - Convenience, N - Other(note in comments)

Installed Part Status: N - New, R - Repaired/Rebuilt, S - Serviceable, O - Overhauled

Repair Facility _____	Certified Repair Station Number _____	Work Order No. _____
Work Performed By <u>CHAZ MICHAEL C DATU</u>	Certificate No. <u>126124AMT</u>	Date <u>14-Sep-2015</u>
I certify that the above stated maintenance and/or inspection was performed in accordance with the current regulations of the		
<input checked="" type="checkbox"/> Federal Aviation Administration <input type="checkbox"/> Other (Specify) _____ and _____		
THE AIRCRAFT IDENTIFIED ABOVE IS PRESENTLY AIRWORTHY AND APPROVED FOR RETURN TO SERVICE.		
Work Inspected By <u>NESTOR DERPO</u>	Certificate No. <u>119184AMT</u>	Date <u>14-Sep-2015</u>
Pertinent details of this maintenance are on file at our facility under the above Work/Service Order Number as applicable.		

Maintenance Log	
Book	Page



Maintenance Transaction Record



This Maintenance Report is To Be Used Solely For (Check One)

Airframe Entries
 Eng. Serial No. _____
 Prop. Serial No. _____

CAMP Systems International
 8200 E. 34TH STREET
 BUILDING 1600, SUITE 1607
 Wichita, KS 67226
 Phone: 316-462-2267/ Fax: 316-462-0791

Aircraft Identification and Status

A/C Serial #	A/C Unit #	A/C Registration #	Date	City ID	Total A/C Hours	Total A/C Landings	Total Engine Hrs	Total Engine Cycles	Total Prop Hrs			
208B-5098		RP-C1087	10-Sep-2015	MNL	476.7	549	476.7	549	476.7			

Component Changes, Inspections, Service Bulletins, or Airworthiness Directives Accomplished

Item	Transaction No.	Type	Item Name	Position	Part Number / Alternate Part Number	Mod Level	Part Serial	Removal Reason	Installed Part Status	TSN/TSO/TSR	Material Costs	Man Hours
280347	1	1	FUEL PRESSURE SWITCH Comments: Removed part no: 1103P1356 Removed serial no: 0119.		S2615-4		0270	UN	N	0 MTH 0 HRS		
710033	2	1	T#5 TRIM STICK Comments: Removed part no: 3031417CL40 Removed serial no: NSN.		3031417CL40		NSN	UN	N	0 MTH 0 HRS		

Trans. Type: 1 - Component, 2 - Inspection, 3 - SB, 4 - AD, - - Misc.

Removal Reasons: WO - Worn to Limits, SC - Scheduled, UN - Unscheduled, CO - Convenience, N - Other(note in comments)

Installed Part Status: N - New, R - Repaired/Rebuilt, S - Serviceable, O - Overhauled

Repair Facility _____ **Certified Repair Station Number** _____ **Work Order No.** 15137

Work Performed By CHAZ MICHAEL C DATU **Certificate No.** 126124AMT **Date** 10-Sep-2015

I certify that the above stated maintenance and/or inspection was performed in accordance with the current regulations of the
 Federal Aviation Administration
 Other (Specify) CAAP _____ and _____

THE AIRCRAFT IDENTIFIED ABOVE IS PRESENTLY AIRWORTHY AND APPROVED FOR RETURN TO SERVICE.

Work Inspected By NESTOR DERPO **Certificate No.** 119184AMT **Date** 10-Sep-2015

Pertinent details of this maintenance are on file at our facility under the above Work/Service Order Number as applicable.

Maintenance Log	
Book	Page



Maintenance Transaction Record



This Maintenance Report is To Be Used Solely For (Check One)

Airframe Entries
 Eng. Serial No. _____
 Prop. Serial No. _____

CAMP Systems International
 8200 E. 34TH STREET
 BUILDING 1600, SUITE 1607
 Wichita, KS 67226
 Phone: 316-462-2267/ Fax: 316-462-0791

Aircraft Identification and Status

A/C Serial #	A/C Unit #	A/C Registration #	Date	City ID	Total A/C Hours	Total A/C Landings	Total Engine Hrs	Total Engine Cycles	Total Prop Hrs			
208B-5098		RP-C1087	02-Sep-2015	MNL	476.4	549	476.4	549	476.4			

Component Changes, Inspections, Service Bulletins, or Airworthiness Directives Accomplished

Item	Transaction No.	Type	Item Name	Position	Part Number / Alternate Part Number	Mod Level	Part Serial	Removal Reason	Installed Part Status	TSN/TSO/TSR	Material Costs	Man Hours
240501	1	1	BATTERY		9750W0538		LEAD ACID-24V37	150860002	CO	N	0 MTH 0 HRS	
Comments: Removed part no: RG380E/44 Removed serial no: 40682863.												

Trans. Type: 1 - Component, 2 - Inspection, 3 - SB, 4 - AD, - - Misc.

Removal Reasons: WO - Worn to Limits, SC - Scheduled, UN - Unscheduled, CO - Convenience, N - Other(note in comments)

Installed Part Status: N - New, R - Repaired/Rebuilt, S - Serviceable, O - Overhauled

Repair Facility _____ **Certified Repair Station Number** _____ **Work Order No.** 15120

Work Performed By CHAZ MICHAEL C DATU **Certificate No.** 126124 -AMT **Date** 02-Sep-2015

I certify that the above stated maintenance and/or inspection was performed in accordance with the current regulations of the
 Federal Aviation Administration
 Other (Specify) CAAP _____ and _____

THE AIRCRAFT IDENTIFIED ABOVE IS PRESENTLY AIRWORTHY AND APPROVED FOR RETURN TO SERVICE.

Work Inspected By NESTOR DERPO **Certificate No.** 119184 - AMT **Date** 02-Sep-2015

Pertinent details of this maintenance are on file at our facility under the above Work/Service Order Number as applicable.

Maintenance Log	
Book	Page



Maintenance Transaction Record



This Maintenance Report is To Be Used Solely For (Check One)

Airframe Entries Eng. Serial No. _____ Prop. Serial No. _____

CAMP Systems International
8200 E. 34TH STREET
BUILDING 1600, SUITE 1607
Wichita, KS 67226
Phone: 316-462-2267/ Fax: 316-462-0791

Aircraft Identification and Status

A/C Serial #	A/C Unit #	A/C Registration #	Date	City ID	Total A/C Hours	Total A/C Landings	Total Engine Hrs	Total Engine Cycles	Total Prop Hrs			
208B-5098		RP-C1087	02-Sep-2015	MNL	476.4	549	476.4	549	476.4			

Component Changes, Inspections, Service Bulletins, or Airworthiness Directives Accomplished

Item	Transaction No.	Type	Item Name	Position	Part Number / Alternate Part Number	Mod Level	Part Serial	Removal Reason	Installed Part Status	TSN/TSO/TSR	Material Costs	Man Hours
CAB-30-03	1	3	TKS FILL CAP PLACARD REPLACEMENT, SERVICE BULLETIN Comments: NOT APPLICABLE									
CAB-30-07	2	3	TKS ICE WARNING PLACARD REPLACEMENT, SERVICE BULLETIN Comments: NOT APPLICABLE									
FAA 2015-10-51	3	4	APPLIANCE AD - AVIDYNE INTEGRATED FLIGHT DISPLAY (IFD)- INCORPORATE OPERATIONAL LIMITATIONS INTO LIMITATIONS SECTION OF THE AFM OR AFMS Comments: NOT APPLICABLE									

Trans. Type: 1 - Component, 2 - Inspection, 3 - SB, 4 - AD, - - Misc.

Removal Reasons: WO - Worn to Limits, SC - Scheduled, UN - Unscheduled, CO - Convenience, N - Other(note in comments)

Installed Part Status: N - New, R - Repaired/Rebuilt, S - Serviceable, O - Overhauled

Repair Facility _____ **Certified Repair Station Number** _____ **Work Order No.** 15124 **Date** 02-Sep-2015
Work Performed By DAVE BANARES **Certificate No.** 114533-AMT
 I certify that the above stated maintenance and/or inspection was performed in accordance with the current regulations of the
 Federal Aviation Administration Other (Specify) CAAP _____ and
 THE AIRCRAFT IDENTIFIED ABOVE IS PRESENTLY AIRWORTHY AND APPROVED FOR RETURN TO SERVICE.
Work Inspected By NESTOR DERPO **Certificate No.** 119184 - AMT **Date** 02-Sep-2015
 Pertinent details of this maintenance are on file at our facility under the above Work/Service Order Number as applicable.

Maintenance Log	
Book	Page



Maintenance Transaction Record



This Maintenance Report is To Be Used Solely For (Check One)

Airframe Entries Eng. Serial No. _____ Prop. Serial No. _____

CAMP Systems International
8200 E. 34TH STREET
BUILDING 1600, SUITE 1607
Wichita, KS 67226
Phone: 316-462-2267/ Fax: 316-462-0791

Aircraft Identification and Status

A/C Serial #	A/C Unit #	A/C Registration #	Date	City ID	Total A/C Hours	Total A/C Landings	Total Engine Hrs	Total Engine Cycles	Total Prop Hrs			
208B-5098		RP-C1087	24-Aug-2015	MNL	476.4	549	476.4	549	476.4			

Component Changes, Inspections, Service Bulletins, or Airworthiness Directives Accomplished

Item	Transaction No.	Type	Item Name	Position	Part Number / Alternate Part Number	Mod Level	Part Serial	Removal Reason	Installed Part Status	TSN/TSO/TSR	Material Costs	Man Hours
CAB-57-02	1	3	SPAR FITTING AND ATTACH BRACKET INSPECTION, SERVICE BULLETIN									
Comments:												

Trans. Type: 1 - Component, 2 - Inspection, 3 - SB, 4 - AD, - - Misc.

Removal Reasons: WO - Worn to Limits, SC - Scheduled, UN - Unscheduled, CO - Convenience, N - Other(note in comments)

Installed Part Status: N - New, R - Repaired/Rebuilt, S - Serviceable, O - Overhauled

Repair Facility _____	Certified Repair Station Number _____	Work Order No. 15111
Work Performed By ARISTEO ALCALA	Certificate No. 115162-AMT	Date 24-Aug-2015
I certify that the above stated maintenance and/or inspection was performed in accordance with the current regulations of the <input type="checkbox"/> Federal Aviation Administration <input checked="" type="checkbox"/> Other (Specify) CAAP _____ and THE AIRCRAFT IDENTIFIED ABOVE IS PRESENTLY AIRWORTHY AND APPROVED FOR RETURN TO SERVICE.		
Work Inspected By DAVE BANARES	Certificate No. 114533 - AMT	Date 24-Aug-2015
Pertinent details of this maintenance are on file at our facility under the above Work/Service Order Number as applicable.		

Maintenance Log	
Book	Page



Maintenance Transaction Record



This Maintenance Report is To Be Used Solely For (Check One)

Airframe Entries
 Eng. Serial No. _____
 Prop. Serial No. _____

CAMP Systems International
 8200 E. 34TH STREET
 BUILDING 1600, SUITE 1607
 Wichita, KS 67226
 Phone: 316-462-2267/ Fax: 316-462-0791

Aircraft Identification and Status

A/C Serial #	A/C Unit #	A/C Registration #	Date	City ID	Total A/C Hours	Total A/C Landings	Total Engine Hrs	Total Engine Cycles	Total Prop Hrs			
208B-5098		RP-C1087	10-Jun-2015	MNL	476.2	513	476.2	513	476.2			

Component Changes, Inspections, Service Bulletins, or Airworthiness Directives Accomplished

Item	Transaction No.	Type	Item Name	Position	Part Number / Alternate Part Number	Mod Level	Part Serial	Removal Reason	Installed Part Status	TSN/TSO/TSR	Material Costs	Man Hours
051260	1	2	INSPECT 25 HR INSP-FLOATS									
Comments:												
051265	2	2	INSPECT 50 HR INSP-FLOATS									
Comments:												

Trans. Type: 1 - Component, 2 - Inspection, 3 - SB, 4 - AD, - - Misc.

Removal Reasons: WO - Worn to Limits, SC - Scheduled, UN - Unscheduled, CO - Convenience, N - Other(note in comments)

Installed Part Status: N - New, R - Repaired/Rebuilt, S - Serviceable, O - Overhauled

Repair Facility _____ Certified Repair Station Number _____ Work Order No. 15154 Work Performed By CHAZ MICHAEL C DATU Certificate No. 126124AMT Date 10-Jun-2015 I certify that the above stated maintenance and/or inspection was performed in accordance with the current regulations of the <input type="checkbox"/> Federal Aviation Administration <input checked="" type="checkbox"/> Other (Specify) CAAP _____ and _____ THE AIRCRAFT IDENTIFIED ABOVE IS PRESENTLY AIRWORTHY AND APPROVED FOR RETURN TO SERVICE. Work Inspected By NESTOR DERPO Certificate No. 119184AMT Date 10-Jun-2015 Pertinent details of this maintenance are on file at our facility under the above Work/Service Order Number as applicable.

Maintenance Log	
Book	Page



Maintenance Transaction Record



This Maintenance Report is To Be Used Solely For (Check One)

Airframe Entries
 Eng. Serial No. _____
 Prop. Serial No. _____

CAMP Systems International
 8200 E. 34TH STREET
 BUILDING 1600, SUITE 1607
 Wichita, KS 67226
 Phone: 316-462-2267/ Fax: 316-462-0791

Aircraft Identification and Status

A/C Serial #	A/C Unit #	A/C Registration #	Date	City ID	Total A/C Hours	Total A/C Landings	Total Engine Hrs	Total Engine Cycles	Total Prop Hrs			
208B-5098		RP-C1087	28-May-2015	MNL	425.4	482	425.4	482	425.4			

Component Changes, Inspections, Service Bulletins, or Airworthiness Directives Accomplished

Item	Transaction No. Type	Item Name	Position	Part Number / Alternate Part Number	Mod Level	Part Serial	Removal Reason	InstalledPart Status TSN/TSO/TSR	Material Costs	Man Hours
051260	1 2	INSPECT 25 HR INSP-FLOATS								
Comments:										

Trans. Type: 1 - Component, 2 - Inspection, 3 - SB, 4 - AD, - - Misc.

Removal Reasons: WO - Worn to Limits, SC - Scheduled, UN - Unscheduled, CO - Convenience, N - Other(note in comments)

Installed Part Status: N - New, R - Repaired/Rebuilt, S - Serviceable, O - Overhauled

Repair Facility _____ **Certified Repair Station Number** _____ **Work Order No.** 150037

Work Performed By CHAZ MICHAEL C DATU **Certificate No.** 126124 -AMT **Date** 28-May-2015

I certify that the above stated maintenance and/or inspection was performed in accordance with the current regulations of the

Federal Aviation Administration
 Other (Specify) CAAP _____ and

THE AIRCRAFT IDENTIFIED ABOVE IS PRESENTLY AIRWORTHY AND APPROVED FOR RETURN TO SERVICE.

Work Inspected By NESTOR DERPO **Certificate No.** 119184 - AMT **Date** 28-May-2015

Pertinent details of this maintenance are on file at our facility under the above Work/Service Order Number as applicable.

Maintenance Log	
Book	Page



Maintenance Transaction Record



This Maintenance Report is To Be Used Solely For (Check One)

Airframe Entries Eng. Serial No. _____ Prop. Serial No. _____

CAMP Systems International
8200 E. 34TH STREET
BUILDING 1600, SUITE 1607
Wichita, KS 67226
Phone: 316-462-2267/ Fax: 316-462-0791

Aircraft Identification and Status

A/C Serial #	A/C Unit #	A/C Registration #	Date	City ID	Total A/C Hours	Total A/C Landings	Total Engine Hrs	Total Engine Cycles	Total Prop Hrs			
208B-5098		RP-C1087	21-May-2015	MNL	403.3	455	403.3	455	403.3			

Component Changes, Inspections, Service Bulletins, or Airworthiness Directives Accomplished

Item	Transaction No.	Type	Item Name	Position	Part Number / Alternate Part Number	Mod Level	Part Serial	Removal Reason	Installed Part Status	TSN/TSO/TSR	Material Costs	Man Hours
5-15-06	1	2	INSPECTION DOCUMENT 06									
Comments:												
5-15-08	2	2	INSPECTION DOCUMENT 08									
Comments: CHANGE AIR CONDITION BELT. WITH PN: F8263												
790010	3	2	NO. 1 ENGINE - OIL CHANGE									
Comments:												

Trans. Type: 1 - Component, 2 - Inspection, 3 - SB, 4 - AD, - - Misc.

Removal Reasons: WO - Worn to Limits, SC - Scheduled, UN - Unscheduled, CO - Convenience, N - Other(note in comments)

Installed Part Status: N - New, R - Repaired/Rebuilt, S - Serviceable, O - Overhauled

Repair Facility _____ **Certified Repair Station Number** _____ **Work Order No.** 150011
Work Performed By KRISTOFER ALLEN GABISON **Certificate No.** 110205 AMT **Date** 21-May-2015
 I certify that the above stated maintenance and/or inspection was performed in accordance with the current regulations of the
 Federal Aviation Administration Other (Specify) CAAP _____ and
 THE AIRCRAFT IDENTIFIED ABOVE IS PRESENTLY AIRWORTHY AND APPROVED FOR RETURN TO SERVICE.
Work Inspected By NESTOR DERPO **Certificate No.** 119184 - AMT **Date** 21-May-2015
 Pertinent details of this maintenance are on file at our facility under the above Work/Service Order Number as applicable.

Maintenance Log	
Book	Page



Maintenance Transaction Record



This Maintenance Report is To Be Used Solely For (Check One)

Airframe Entries
 Eng. Serial No. _____
 Prop. Serial No. _____

CAMP Systems International
 8200 E. 34TH STREET
 BUILDING 1600, SUITE 1607
 Wichita, KS 67226
 Phone: 316-462-2267/ Fax: 316-462-0791

Aircraft Identification and Status

A/C Serial #	A/C Unit #	A/C Registration #	Date	City ID	Total A/C Hours	Total A/C Landings	Total Engine Hrs	Total Engine Cycles	Total Prop Hrs			
208B-5098		RP-C1087	21-May-2015	MNL	403.3	455	403.3	455	403.3			

Component Changes, Inspections, Service Bulletins, or Airworthiness Directives Accomplished

Item	Transaction No.	Type	Item Name	Position	Part Number / Alternate Part Number	Mod Level	Part Serial	Removal Reason	Installed Part Status	TSN/TSO/TSR	Material Costs	Man Hours
051260	1	2	INSPECT 25 HR INSP-FLOATS									
Comments:												
051265	2	2	INSPECT 50 HR INSP-FLOATS									
Comments:												
051270	3	2	INSPECT 100 HR INSP-FLOATS									
Comments:												
051275	4	2	INSPECT 200 HR INSP-FLOATS									
Comments:												
321106F	5	1	LEFT OUTBOARD BRAKE PRESSURE PLATE	LEFT OUTBOARD	PN 073-4200			NSN	UN	N	0 MTH 0 HRS	
321106F : LO Comments: Removed part no: PN 073-4200 Removed serial no: NSN.												
321106F	6	1	LEFT INBOARD BRAKE PRESSURE PLATE	LEFT INBOARD	PN073-04200			NSN	WO	N	0 MTH 0 HRS	
321106F : LI Comments: Removed part no: PN073-04200 Removed serial no: NSN.												
321106F	7	1	RIGHT INBOARD BRAKE PRESSURE PLATE	RIGHT INBOARD	PN073-04200			NSN	WO	N	0 MTH 0 HRS	
321106F : RI Comments: Removed part no: PN073-04200 Removed serial no: NSN.												
321106F	8	1	RIGHT OUTBOARD BRAKE PRESSURE PLATE	RIGHT OUTBOARD	PN073-04200			NSN	WO	N	0 MTH 0 HRS	
321106F : RO Comments: Removed part no: PN073-04200 Removed serial no: NSN.												

Trans. Type: 1 - Component, 2 - Inspection, 3 - SB, 4 - AD, - - Misc.

Removal Reasons: WO - Worn to Limits, SC - Scheduled, UN - Unscheduled, CO - Convenience, N - Other(note in comments)

Installed Part Status: N - New, R - Repaired/Rebuilt, S - Serviceable, O - Overhauled

Repair Facility _____ Certified Repair Station Number _____ Work Order No. 150011 Work Performed By ARISTEO ALCALA Certificate No. 115162-AMT Date 21-May-2015 I certify that the above stated maintenance and/or inspection was performed in accordance with the current regulations of the <input type="checkbox"/> Federal Aviation Administration <input checked="" type="checkbox"/> Other (Specify) CAAP _____ and THE AIRCRAFT IDENTIFIED ABOVE IS PRESENTLY AIRWORTHY AND APPROVED FOR RETURN TO SERVICE. Work Inspected By NESTOR DERPO Certificate No. 119184 - AMT Date 21-May-2015 Pertinent details of this maintenance are on file at our facility under the above Work/Service Order Number as applicable.

Maintenance Log	
Book	Page



Maintenance Transaction Record



This Maintenance Report is To Be Used Solely For (Check One)

Airframe Entries
 Eng. Serial No. _____
 Prop. Serial No. _____

CAMP Systems International
 8200 E. 34TH STREET
 BUILDING 1600, SUITE 1607
 Wichita, KS 67226
 Phone: 316-462-2267/ Fax: 316-462-0791

Aircraft Identification and Status

A/C Serial #	A/C Unit #	A/C Registration #	Date	City ID	Total A/C Hours	Total A/C Landings	Total Engine Hrs	Total Engine Cycles	Total Prop Hrs			
208B-5098		RP-C1087	21-May-2015	MNL	403.3	455	403.3	455	403.3			

Component Changes, Inspections, Service Bulletins, or Airworthiness Directives Accomplished

Item	Transaction No.	Type	Item Name	Position	Part Number / Alternate Part Number	Mod Level	Part Serial	Removal Reason	Installed Part Status	TSN/TSO/TSR	Material Costs	Man Hours
321110F 321110F : LI	9	1	LEFT INBOARD BRAKE BACK PLATE	LEFT INBOARD	PN07302900		NSN	WO	N	0 MTH 0 HRS		
Comments: Removed part no: PN07302900 Removed serial no: NSN.												
321110F 321110F : RI	10	1	RIGHT INBOARD BRAKE BACK PLATE	RIGHT INBOARD	PN074-002900		NSN	WO	N	0 MTH 0 HRS		
Comments: Removed part no: PN074-002900 Removed serial no: NSN.												
321110F 321110F : LO	11	1	LEFT OUTBOARD BRAKE BACK PLATE	LEFT OUTBOARD	PN074-02900		NSN	WO	N	0 MTH 0 HRS		
Comments: Removed part no: PN074-02900 Removed serial no: NSN.												
321110F 321110F : RO	12	1	RIGHT OUTBOARD BRAKE BACK PLATE	RIGHT OUTBOARD	PN074-02900		NSN	WO	N	0 MTH 0 HRS		
Comments: Removed part no: PN074-02900 Removed serial no: NSN.												

Trans. Type: 1 - Component, 2 - Inspection, 3 - SB, 4 - AD, - - Misc.

Removal Reasons: WO - Worn to Limits, SC - Scheduled, UN - Unscheduled, CO - Convenience, N - Other(note in comments)

Installed Part Status: N - New, R - Repaired/Rebuilt, S - Serviceable, O - Overhauled

Repair Facility _____	Certified Repair Station Number _____	Work Order No. 150011
Work Performed By ARISTEO ALCALA	Certificate No. 115162-AMT	Date 21-May-2015
I certify that the above stated maintenance and/or inspection was performed in accordance with the current regulations of the <input type="checkbox"/> Federal Aviation Administration <input checked="" type="checkbox"/> Other (Specify) CAAP _____ and THE AIRCRAFT IDENTIFIED ABOVE IS PRESENTLY AIRWORTHY AND APPROVED FOR RETURN TO SERVICE.		
Work Inspected By NESTOR DERPO	Certificate No. 119184 - AMT	Date 21-May-2015
Pertinent details of this maintenance are on file at our facility under the above Work/Service Order Number as applicable.		

Maintenance Log	
Book	Page



Maintenance Transaction Record



This Maintenance Report is To Be Used Solely For (Check One)

Airframe Entries Eng. Serial No. _____ Prop. Serial No. _____

CAMP Systems International
8200 E. 34TH STREET
BUILDING 1600, SUITE 1607
Wichita, KS 67226
Phone: 316-462-2267/ Fax: 316-462-0791

Aircraft Identification and Status

A/C Serial #	A/C Unit #	A/C Registration #	Date	City ID	Total A/C Hours	Total A/C Landings	Total Engine Hrs	Total Engine Cycles	Total Prop Hrs			
208B-5098		RP-C1087	15-May-2015	MNL	397.4	448	397.4	448	397.4			

Component Changes, Inspections, Service Bulletins, or Airworthiness Directives Accomplished

Item	Transaction No.	Type	Item Name	Position	Part Number / Alternate Part Number	Mod Level	Part Serial	Removal Reason	Installed Part Status	TSN/TSO/TSR	Material Costs	Man Hours
240501	1	1	BATTERY		RG380E/44	4 / LEAD ACID	40682863	UN	N	0 MTH 0 HRS		
Comments: Removed part no: RG380E/40B Removed serial no: 40601496.												

Trans. Type: 1 - Component, 2 - Inspection, 3 - SB, 4 - AD, - - Misc.

Removal Reasons: WO - Worn to Limits, SC - Scheduled, UN - Unscheduled, CO - Convenience, N - Other(note in comments)

Installed Part Status: N - New, R - Repaired/Rebuilt, S - Serviceable, O - Overhauled

Repair Facility _____ **Certified Repair Station Number** _____ **Work Order No.** 150014
Work Performed By CHAZ MICHAEL C DATU **Certificate No.** 126124 -AMT **Date** 15-May-2015
 I certify that the above stated maintenance and/or inspection was performed in accordance with the current regulations of the
 Federal Aviation Administration Other (Specify) CAAP _____ and
 THE AIRCRAFT IDENTIFIED ABOVE IS PRESENTLY AIRWORTHY AND APPROVED FOR RETURN TO SERVICE.
Work Inspected By NESTOR DERPO **Certificate No.** 119184 - AMT **Date** 15-May-2015
 Pertinent details of this maintenance are on file at our facility under the above Work/Service Order Number as applicable.

Maintenance Log	
Book	Page



Maintenance Transaction Record



This Maintenance Report is To Be Used Solely For (Check One)

Airframe Entries Eng. Serial No. _____ Prop. Serial No. _____

CAMP Systems International
8200 E. 34TH STREET
BUILDING 1600, SUITE 1607
Wichita, KS 67226
Phone: 316-462-2267/ Fax: 316-462-0791

Aircraft Identification and Status

A/C Serial #	A/C Unit #	A/C Registration #	Date	City ID	Total A/C Hours	Total A/C Landings	Total Engine Hrs	Total Engine Cycles	Total Prop Hrs			
208B-5098		RP-C1087	12-May-2015	MNL	386.4	432	386.4	432	386.4			

Component Changes, Inspections, Service Bulletins, or Airworthiness Directives Accomplished

Item	Transaction No. Type	Item Name	Position	Part Number / Alternate Part Number	Mod Level	Part Serial	Removal Reason	Installed Part Status	TSN/TSO/TSR	Material Costs	Man Hours
320301F	1 1	LEFT OUTBOARD (FLOAT) TIRE		LEFT OUTBOARD 30605		AIE 64313	UN	N	0 MTH 0 HRS		
Comments: Removed part no: 30605 Removed serial no: AIE 63213											

Trans. Type: 1 - Component, 2 - Inspection, 3 - SB, 4 - AD, - - Misc.

Removal Reasons: WO - Worn to Limits, SC - Scheduled, UN - Unscheduled, CO - Convenience, N - Other(note in comments)

Installed Part Status: N - New, R - Repaired/Rebuilt, S - Serviceable, O - Overhauled

Repair Facility _____ **Certified Repair Station Number** _____ **Work Order No.** 15009
Work Performed By ARISTEO ALCALA **Certificate No.** 115162-AMT **Date** 12-May-2015
 I certify that the above stated maintenance and/or inspection was performed in accordance with the current regulations of the
 Federal Aviation Administration Other (Specify) CAAP _____ and
 THE AIRCRAFT IDENTIFIED ABOVE IS PRESENTLY AIRWORTHY AND APPROVED FOR RETURN TO SERVICE.
Work Inspected By NESTOR DERPO **Certificate No.** 119184 - AMT **Date** 12-May-2015
 Pertinent details of this maintenance are on file at our facility under the above Work/Service Order Number as applicable.

Maintenance Log	
Book	Page



Maintenance Transaction Record



This Maintenance Report is To Be Used Solely For (Check One)

Airframe Entries Eng. Serial No. _____ Prop. Serial No. _____

CAMP Systems International
8200 E. 34TH STREET
BUILDING 1600, SUITE 1607
Wichita, KS 67226
Phone: 316-462-2267/ Fax: 316-462-0791

Aircraft Identification and Status

A/C Serial #	A/C Unit #	A/C Registration #	Date	City ID	Total A/C Hours	Total A/C Landings	Total Engine Hrs	Total Engine Cycles	Total Prop Hrs			
208B-5098		RP-C1087	06-May-2015	MNL	372.4	413	372.4	413	372.4			

Component Changes, Inspections, Service Bulletins, or Airworthiness Directives Accomplished

Item	Transaction No.	Type	Item Name	Position	Part Number / Alternate Part Number	Mod Level	Part Serial	Removal Reason	Installed Part Status	TSN/TSO/TSR	Material Costs	Man Hours
051260	1	2	INSPECT 25 HR INSP-FLOATS									
Comments:												
320302F	2	1	RIGHT INBOARD (FLOAT) WHEEL ASSEMBLY	RIGHT INBOARD	8A04000-031		A1E63213	UN	N	0 MTH 0 HRS		
Comments: Removed part no: 8A04000-031 Removed serial no: A1E63213												

Trans. Type: 1 - Component, 2 - Inspection, 3 - SB, 4 - AD, - - Misc.

Removal Reasons: WO - Worn to Limits, SC - Scheduled, UN - Unscheduled, CO - Convenience, N - Other(note in comments)

Installed Part Status: N - New, R - Repaired/Rebuilt, S - Serviceable, O - Overhauled

Repair Facility _____	Certified Repair Station Number _____	Work Order No. _____
Work Performed By KRISTOFER ALLEN GABISON	Certificate No. 110205 AMT	Date 06-May-2015
I certify that the above stated maintenance and/or inspection was performed in accordance with the current regulations of the		
<input type="checkbox"/> Federal Aviation Administration <input checked="" type="checkbox"/> Other (Specify) CAAP _____ and _____		
THE AIRCRAFT IDENTIFIED ABOVE IS PRESENTLY AIRWORTHY AND APPROVED FOR RETURN TO SERVICE.		
Work Inspected By NESTOR DERPO	Certificate No. 11984 - AMT	Date 06-May-2015
Pertinent details of this maintenance are on file at our facility under the above Work/Service Order Number as applicable.		

Maintenance Log	
Book	Page



Maintenance Transaction Record



This Maintenance Report is To Be Used Solely For (Check One)

Airframe Entries
 Eng. Serial No. _____
 Prop. Serial No. _____

CAMP Systems International
 8200 E. 34TH STREET
 BUILDING 1600, SUITE 1607
 Wichita, KS 67226
 Phone: 316-462-2267/ Fax: 316-462-0791

Aircraft Identification and Status

A/C Serial #	A/C Unit #	A/C Registration #	Date	City ID	Total A/C Hours	Total A/C Landings	Total Engine Hrs	Total Engine Cycles	Total Prop Hrs			
208B-5098		RP-C1087	01-May-2015	MNL	364.9	401	364.9	401	364.9			

Component Changes, Inspections, Service Bulletins, or Airworthiness Directives Accomplished

Item	Transaction No.	Type	Item Name	Position	Part Number / Alternate Part Number	Mod Level	Part Serial	Removal Reason	Installed Part Status	TSN/TSO/TSR	Material Costs	Man Hours
CAB-27-01	1	3	RUDDER TRIM INSPECTION, SERVICE BULLETIN									
Comments: not applicable												

Trans. Type: 1 - Component, 2 - Inspection, 3 - SB, 4 - AD, - - Misc.

Removal Reasons: WO - Worn to Limits, SC - Scheduled, UN - Unscheduled, CO - Convenience, N - Other(note in comments)

Installed Part Status: N - New, R - Repaired/Rebuilt, S - Serviceable, O - Overhauled

Repair Facility _____ **Certified Repair Station Number** _____ **Work Order No.** 15143

Work Performed By CHAZ MICHAEL C DATU **Certificate No.** 126124AMT **Date** 01-May-2015

I certify that the above stated maintenance and/or inspection was performed in accordance with the current regulations of the

Federal Aviation Administration
 Other (Specify) CAAP _____ and _____

THE AIRCRAFT IDENTIFIED ABOVE IS PRESENTLY AIRWORTHY AND APPROVED FOR RETURN TO SERVICE.

Work Inspected By NESTOR DERPO **Certificate No.** 119184AMT **Date** 01-May-2015

Pertinent details of this maintenance are on file at our facility under the above Work/Service Order Number as applicable.

Maintenance Log	
Book	Page



Maintenance Transaction Record



This Maintenance Report is To Be Used Solely For (Check One)

Airframe Entries
 Eng. Serial No. _____
 Prop. Serial No. _____

CAMP Systems International
 8200 E. 34TH STREET
 BUILDING 1600, SUITE 1607
 Wichita, KS 67226
 Phone: 316-462-2267/ Fax: 316-462-0791

Aircraft Identification and Status

A/C Serial #	A/C Unit #	A/C Registration #	Date	City ID	Total A/C Hours	Total A/C Landings	Total Engine Hrs	Total Engine Cycles	Total Prop Hrs			
208B-5098		RP-C1087	27-Apr-2015	MNL	252.1	385	252.1	385	252.1			

Component Changes, Inspections, Service Bulletins, or Airworthiness Directives Accomplished

Item	Transaction No.	Type	Item Name	Position	Part Number / Alternate Part Number	Mod Level	Part Serial	Removal Reason	Installed Part Status	TSN/TSO/TSR	Material Costs	Man Hours
051265	1	2	INSPECT 50 HR INSP-FLOATS									
Comments:												

Trans. Type: 1 - Component, 2 - Inspection, 3 - SB, 4 - AD, - - Misc.

Removal Reasons: WO - Worn to Limits, SC - Scheduled, UN - Unscheduled, CO - Convenience, N - Other(note in comments)

Installed Part Status: N - New, R - Repaired/Rebuilt, S - Serviceable, O - Overhauled

Repair Facility _____ Certified Repair Station Number _____ Work Order No. _____ Work Performed By <u>CHAZ MICHAEL C DATU</u> Certificate No. <u>126124 -AMT</u> Date <u>27-Apr-2015</u> I certify that the above stated maintenance and/or inspection was performed in accordance with the current regulations of the <input checked="" type="checkbox"/> Federal Aviation Administration <input type="checkbox"/> Other (Specify) _____ and THE AIRCRAFT IDENTIFIED ABOVE IS PRESENTLY AIRWORTHY AND APPROVED FOR RETURN TO SERVICE. Work Inspected By <u>NESTOR DERPO</u> Certificate No. <u>11984 - AMT</u> Date <u>27-Apr-2015</u> Pertinent details of this maintenance are on file at our facility under the above Work/Service Order Number as applicable.
--

Maintenance Log	
Book	Page



Maintenance Transaction Record



This Maintenance Report is To Be Used Solely For (Check One)

Airframe Entries
 Eng. Serial No. _____
 Prop. Serial No. _____

CAMP Systems International
 8200 E. 34TH STREET
 BUILDING 1600, SUITE 1607
 Wichita, KS 67226
 Phone: 316-462-2267/ Fax: 316-462-0791

Aircraft Identification and Status

A/C Serial #	A/C Unit #	A/C Registration #	Date	City ID	Total A/C Hours	Total A/C Landings	Total Engine Hrs	Total Engine Cycles	Total Prop Hrs			
208B-5098		RP-C1087	26-Apr-2015	MNL	349.3	382	349.3	382	349.3			

Component Changes, Inspections, Service Bulletins, or Airworthiness Directives Accomplished

Item	Transaction No. Type	Item Name	Position	Part Number / Alternate Part Number	Mod Level	Part Serial	Removal Reason	InstalledPart Status TSN/TSO/TSR	Material Costs	Man Hours
051265	1 2	INSPECT 50 HR INSP-FLOATS								
Comments:										

Trans. Type: 1 - Component, 2 - Inspection, 3 - SB, 4 - AD, - - Misc.

Removal Reasons: WO - Worn to Limits, SC - Scheduled, UN - Unscheduled, CO - Convenience, N - Other(note in comments)

Installed Part Status: N - New, R - Repaired/Rebuilt, S - Serviceable, O - Overhauled

Repair Facility _____	Certified Repair Station Number _____	Work Order No. _____
Work Performed By <u>ARISTEO ALCALA</u>	Certificate No. <u>115162-AMT</u>	Date <u>26-Apr-2015</u>
I certify that the above stated maintenance and/or inspection was performed in accordance with the current regulations of the <input checked="" type="checkbox"/> Federal Aviation Administration <input type="checkbox"/> Other (Specify) _____ and _____ THE AIRCRAFT IDENTIFIED ABOVE IS PRESENTLY AIRWORTHY AND APPROVED FOR RETURN TO SERVICE.		
Work Inspected By <u>NESTOR DERPO</u>	Certificate No. <u>11984 - AMT</u>	Date <u>26-Apr-2015</u>
Pertinent details of this maintenance are on file at our facility under the above Work/Service Order Number as applicable.		

Maintenance Log	
Book	Page



Maintenance Transaction Record



This Maintenance Report is To Be Used Solely For (Check One)

Airframe Entries Eng. Serial No. _____ Prop. Serial No. _____

CAMP Systems International
8200 E. 34TH STREET
BUILDING 1600, SUITE 1607
Wichita, KS 67226
Phone: 316-462-2267/ Fax: 316-462-0791

Aircraft Identification and Status

A/C Serial #	A/C Unit #	A/C Registration #	Date	City ID	Total A/C Hours	Total A/C Landings	Total Engine Hrs	Total Engine Cycles	Total Prop Hrs			
208B-5098		RP-C1087	18-Apr-2015	MNL	322.9	325	322.9	325	322.9			

Component Changes, Inspections, Service Bulletins, or Airworthiness Directives Accomplished

Item	Transaction No. Type	Item Name	Position	Part Number / Alternate Part Number	Mod Level	Part Serial	Removal Reason	InstalledPart Status TSN/TSO/TSR	Material Costs	Man Hours
051260	1 2	INSPECT 25 HR INSP-FLOATS								
Comments:										

Trans. Type: 1 - Component, 2 - Inspection, 3 - SB, 4 - AD, - - Misc.

Removal Reasons: WO - Worn to Limits, SC - Scheduled, UN - Unscheduled, CO - Convenience, N - Other(note in comments)

Installed Part Status: N - New, R - Repaired/Rebuilt, S - Serviceable, O - Overhauled

Repair Facility _____	Certified Repair Station Number _____	Work Order No. _____
Work Performed By <u>ARISTEO ALCALA</u>	Certificate No. <u>115162-AMT</u>	Date <u>18-Apr-2015</u>
I certify that the above stated maintenance and/or inspection was performed in accordance with the current regulations of the <input type="checkbox"/> Federal Aviation Administration <input checked="" type="checkbox"/> Other (Specify) <u>CAAP</u> and _____		
THE AIRCRAFT IDENTIFIED ABOVE IS PRESENTLY AIRWORTHY AND APPROVED FOR RETURN TO SERVICE.		
Work Inspected By <u>NESTOR DERPO</u>	Certificate No. <u>11984 - AMT</u>	Date <u>18-Apr-2015</u>
Pertinent details of this maintenance are on file at our facility under the above Work/Service Order Number as applicable.		

Maintenance Log	
Book	Page



Maintenance Transaction Record



This Maintenance Report is To Be Used Solely For (Check One)

Airframe Entries
 Eng. Serial No. _____
 Prop. Serial No. _____

CAMP Systems International
 8200 E. 34TH STREET
 BUILDING 1600, SUITE 1607
 Wichita, KS 67226
 Phone: 316-462-2267/ Fax: 316-462-0791

Aircraft Identification and Status

A/C Serial #	A/C Unit #	A/C Registration #	Date	City ID	Total A/C Hours	Total A/C Landings	Total Engine Hrs	Total Engine Cycles	Total Prop Hrs			
208B-5098		RP-C1087	18-Apr-2015	MNL	322.9	340	322.9	340	322.9			

Component Changes, Inspections, Service Bulletins, or Airworthiness Directives Accomplished

Item	Transaction No. Type	Item Name	Position	Part Number / Alternate Part Number	Mod Level	Part Serial	Removal Reason	InstalledPart Status TSN/TSO/TSR	Material Costs	Man Hours
051260	1 2	INSPECT 25 HR INSP-FLOATS								
Comments:										

Trans. Type: 1 - Component, 2 - Inspection, 3 - SB, 4 - AD, - - Misc.

Removal Reasons: WO - Worn to Limits, SC - Scheduled, UN - Unscheduled, CO - Convenience, N - Other(note in comments)

Installed Part Status: N - New, R - Repaired/Rebuilt, S - Serviceable, O - Overhauled

Repair Facility _____ Certified Repair Station Number _____ Work Order No. 150052 Work Performed By CHAZ MICHAEL C DATU Certificate No. 126124 -AMT Date 18-Apr-2015 I certify that the above stated maintenance and/or inspection was performed in accordance with the current regulations of the <input type="checkbox"/> Federal Aviation Administration <input checked="" type="checkbox"/> Other (Specify) CAAP _____ and _____ THE AIRCRAFT IDENTIFIED ABOVE IS PRESENTLY AIRWORTHY AND APPROVED FOR RETURN TO SERVICE. Work Inspected By NESTOR DERPO Certificate No. 119184 - AMT Date 18-Apr-2015 Pertinent details of this maintenance are on file at our facility under the above Work/Service Order Number as applicable.

Maintenance Log	
Book	Page



Maintenance Transaction Record



This Maintenance Report is To Be Used Solely For (Check One)

Airframe Entries Eng. Serial No. _____ Prop. Serial No. _____

CAMP Systems International
8200 E. 34TH STREET
BUILDING 1600, SUITE 1607
Wichita, KS 67226
Phone: 316-462-2267/ Fax: 316-462-0791

Aircraft Identification and Status

A/C Serial #	A/C Unit #	A/C Registration #	Date	City ID	Total A/C Hours	Total A/C Landings	Total Engine Hrs	Total Engine Cycles	Total Prop Hrs			
208B-5098		RP-C1087	10-Apr-2015	MNL	298	305	298	305	298			

Component Changes, Inspections, Service Bulletins, or Airworthiness Directives Accomplished

Item	Transaction No.	Type	Item Name	Position	Part Number / Alternate Part Number	Mod Level	Part Serial	Removal Reason	Installed Part Status	TSN/TSO/TSR	Material Costs	Man Hours
057010	1	2	NO. 1 ENGINE - MINOR INSPECTION									
Comments:												
051270	2	2	INSPECT 100 HR INSP-FLOATS									
Comments:												
733020	3	2	NO. 1 ENGINE - CLEAN/REPLACE PNEUMATIC P3 FILTER									
Comments:												
733010	4	2	NO. 1 ENGINE - CLEAN AND INSPECT PNEUMATIC P3 FILTER DRAIN VALVE HOUSING ASSEMBLY									
Comments:												
741025	5	2	NO. 1 ENGINE - INSPECT/CLEAN 4 O	4 O	CH34055				NSN			
Comments:												
741035	6	2	NO. 1 ENGINE - INSPECT/CLEAN 9 O	9 O	CH34055				NSN			
Comments:												
761010	7	2	NO. 1 ENGINE - INSPECT ENGINE CONTROL LINKAGES									
Comments:												
790060	8	2	NO. 1 ENGINE - CLEAN AND INSPECT OIL FILTER ELEMENT AND SECONDARY SCREEN									

Trans. Type: 1 - Component, 2 - Inspection, 3 - SB, 4 - AD, - - Misc.

Removal Reasons: WO - Worn to Limits, SC - Scheduled, UN - Unscheduled, CO - Convenience, N - Other(note in comments)

Installed Part Status: N - New, R - Repaired/Rebuilt, S - Serviceable, O - Overhauled

Repair Facility _____	Certified Repair Station Number _____	Work Order No. _____
Work Performed By KRISTOFER ALLEN GABISON	Certificate No. 110205 AMT	Date 10-Apr-2015
I certify that the above stated maintenance and/or inspection was performed in accordance with the current regulations of the		
<input type="checkbox"/> Federal Aviation Administration <input checked="" type="checkbox"/> Other (Specify) CAAP _____ and _____		
THE AIRCRAFT IDENTIFIED ABOVE IS PRESENTLY AIRWORTHY AND APPROVED FOR RETURN TO SERVICE.		
Work Inspected By NESTOR DERPO	Certificate No. 11984 - AMT	Date 10-Apr-2015
Pertinent details of this maintenance are on file at our facility under the above Work/Service Order Number as applicable.		

Maintenance Log	
Book	Page



Maintenance Transaction Record



This Maintenance Report is To Be Used Solely For (Check One)

Airframe Entries Eng. Serial No. _____ Prop. Serial No. _____

CAMP Systems International
8200 E. 34TH STREET
BUILDING 1600, SUITE 1607
Wichita, KS 67226
Phone: 316-462-2267/ Fax: 316-462-0791

Aircraft Identification and Status

A/C Serial #	A/C Unit #	A/C Registration #	Date	City ID	Total A/C Hours	Total A/C Landings	Total Engine Hrs	Total Engine Cycles	Total Prop Hrs			
208B-5098		RP-C1087	10-Apr-2015	MNL	298	305	298	305	298			

Component Changes, Inspections, Service Bulletins, or Airworthiness Directives Accomplished

Item	Transaction No. Type	Item Name	Position	Part Number / Alternate Part Number	Mod Level	Part Serial	Removal Reason	InstalledPart Status TSN/TSO/TSR	Material Costs	Man Hours
731035	9 1	NO. 1 ENGINE - FUEL FILTER ELEMENT		3059779-01		NSN	SC	N 0 HRS		
Comments: Comments: Removed part no: 3059779-01 Removed serial no: SN-UNKNOWN. inlet and outlet										

Trans. Type: 1 - Component, 2 - Inspection, 3 - SB, 4 - AD, - - Misc.

Removal Reasons: WO - Worn to Limits, SC - Scheduled, UN - Unscheduled, CO - Convenience, N - Other(note in comments)

Installed Part Status: N - New, R - Repaired/Rebuilt, S - Serviceable, O - Overhauled

Repair Facility _____ **Certified Repair Station Number** _____ **Work Order No.** _____
Work Performed By KRISTOFER ALLEN GABISON **Certificate No.** 110205 AMT **Date** 10-Apr-2015
 I certify that the above stated maintenance and/or inspection was performed in accordance with the current regulations of the
 Federal Aviation Administration Other (Specify) CAAP _____ and _____
 THE AIRCRAFT IDENTIFIED ABOVE IS PRESENTLY AIRWORTHY AND APPROVED FOR RETURN TO SERVICE.
Work Inspected By NESTOR DERPO **Certificate No.** 11984 - AMT **Date** 10-Apr-2015
 Pertinent details of this maintenance are on file at our facility under the above Work/Service Order Number as applicable.

Maintenance Log	
Book	Page



Maintenance Transaction Record



This Maintenance Report is To Be Used Solely For (Check One)

Airframe Entries Eng. Serial No. _____ Prop. Serial No. _____

CAMP Systems International
8200 E. 34TH STREET
BUILDING 1600, SUITE 1607
Wichita, KS 67226
Phone: 316-462-2267/ Fax: 316-462-0791

Aircraft Identification and Status

A/C Serial #	A/C Unit #	A/C Registration #	Date	City ID	Total A/C Hours	Total A/C Landings	Total Engine Hrs	Total Engine Cycles	Total Prop Hrs			
208B-5098		RP-C1087	02-Apr-2015	MNL	274.2	276	274.2	276	274.2			

Component Changes, Inspections, Service Bulletins, or Airworthiness Directives Accomplished

Item	Transaction No.	Type	Item Name	Position	Part Number / Alternate Part Number	Mod Level	Part Serial	Removal Reason	Installed Part Status	TSN/TSO/TSR	Material Costs	Man Hours
051260	1	2	INSPECT 25 HR INSP-FLOATS									
Comments:												

Trans. Type: 1 - Component, 2 - Inspection, 3 - SB, 4 - AD, - - Misc.

Removal Reasons: WO - Worn to Limits, SC - Scheduled, UN - Unscheduled, CO - Convenience, N - Other(note in comments)

Installed Part Status: N - New, R - Repaired/Rebuilt, S - Serviceable, O - Overhauled

Repair Facility _____	Certified Repair Station Number _____	Work Order No. _____
Work Performed By KRISTOFER ALLEN GABISON	Certificate No. 110205 AMT	Date 02-Apr-2015
I certify that the above stated maintenance and/or inspection was performed in accordance with the current regulations of the <input type="checkbox"/> Federal Aviation Administration <input checked="" type="checkbox"/> Other (Specify) CAAP _____ and _____ THE AIRCRAFT IDENTIFIED ABOVE IS PRESENTLY AIRWORTHY AND APPROVED FOR RETURN TO SERVICE.		
Work Inspected By NESTOR DERPO	Certificate No. 11984 - AMT	Date 02-Apr-2015
Pertinent details of this maintenance are on file at our facility under the above Work/Service Order Number as applicable.		

Maintenance Log	
Book	Page



Maintenance Transaction Record



This Maintenance Report is To Be Used Solely For (Check One)

Airframe Entries Eng. Serial No. _____ Prop. Serial No. _____

CAMP Systems International
8200 E. 34TH STREET
BUILDING 1600, SUITE 1607
Wichita, KS 67226
Phone: 316-462-2267/ Fax: 316-462-0791

Aircraft Identification and Status

A/C Serial #	A/C Unit #	A/C Registration #	Date	City ID	Total A/C Hours	Total A/C Landings	Total Engine Hrs	Total Engine Cycles	Total Prop Hrs			
208B-5098		RP-C1087	31-Mar-2015	MNL	265.6	265	265.6	265	265.6			

Component Changes, Inspections, Service Bulletins, or Airworthiness Directives Accomplished

Item	Transaction No.	Type	Item Name	Position	Part Number / Alternate Part Number	Mod Level	Part Serial	Removal Reason	Installed Part Status	TSN/TSO/TSR	Material Costs	Man Hours
5-15-01	1	2	INSPECTION DOCUMENT 01									
Comments:												
B262001	2	2	WEIGHT CHECK FIRE EXTINGUISHER PORTABLE		C352TS		Y-649628					
Weight Check Date: 31-Mar-2015												
Comments:												
5-15-07	3	2	INSPECTION DOCUMENT 07									
Comments:												
5-15-09	4	2	INSPECTION DOCUMENT 09									
Comments:												
5-15-20	5	2	INSPECTION DOCUMENT 20									
Comments:												
612010	6	2	NO. 1 PROPELLER - LUBRICATE PROPELLER									
Comments:												
725050	7	2	NO. 1 ENGINE - INSPECT EXHAUST DUCT WELDS									
Comments:												
731100	8	2	NO. 1 ENGINE - OPERATIONAL CHECK CONTROL MANUAL OVERRIDE STATIC SYSTEM									

Trans. Type: 1 - Component, 2 - Inspection, 3 - SB, 4 - AD, - - Misc.

Removal Reasons: WO - Worn to Limits, SC - Scheduled, UN - Unscheduled, CO - Convenience, N - Other(note in comments)

Installed Part Status: N - New, R - Repaired/Rebuilt, S - Serviceable, O - Overhauled

Repair Facility _____	Certified Repair Station Number _____	Work Order No. _____
Work Performed By KRISTOFER ALLEN GABISON	Certificate No. 110205 AMT	Date 31-Mar-2015
I certify that the above stated maintenance and/or inspection was performed in accordance with the current regulations of the		
<input checked="" type="checkbox"/> Federal Aviation Administration <input type="checkbox"/> Other (Specify) _____ and		
THE AIRCRAFT IDENTIFIED ABOVE IS PRESENTLY AIRWORTHY AND APPROVED FOR RETURN TO SERVICE.		
Work Inspected By NESTOR DERPO	Certificate No. 11984 - AMT	Date 31-Mar-2015
Pertinent details of this maintenance are on file at our facility under the above Work/Service Order Number as applicable.		

Maintenance Log	
Book	Page



Maintenance Transaction Record



This Maintenance Report is To Be Used Solely For (Check One)

Airframe Entries
 Eng. Serial No. _____
 Prop. Serial No. _____

CAMP Systems International
 8200 E. 34TH STREET
 BUILDING 1600, SUITE 1607
 Wichita, KS 67226
 Phone: 316-462-2267/ Fax: 316-462-0791

Aircraft Identification and Status

A/C Serial #	A/C Unit #	A/C Registration #	Date	City ID	Total A/C Hours	Total A/C Landings	Total Engine Hrs	Total Engine Cycles	Total Prop Hrs			
208B-5098		RP-C1087	31-Mar-2015	MNL	265.6	265	265.6	265	265.6			

Component Changes, Inspections, Service Bulletins, or Airworthiness Directives Accomplished

Item	Transaction No. Type	Item Name	Position	Part Number / Alternate Part Number	Mod Level	Part Serial	Removal Reason	InstalledPart Status TSN/TSO/TSR	Material Costs	Man Hours
Comments:										

Trans. Type: 1 - Component, 2 - Inspection, 3 - SB, 4 - AD, - - Misc.

Removal Reasons: WO - Worn to Limits, SC - Scheduled, UN - Unscheduled, CO - Convenience, N - Other(note in comments)

Installed Part Status: N - New, R - Repaired/Rebuilt, S - Serviceable, O - Overhauled

Repair Facility _____ Certified Repair Station Number _____ Work Order No. _____ Work Performed By <u>KRISTOFER ALLEN GABISON</u> Certificate No. <u>110205 AMT</u> Date <u>31-Mar-2015</u> I certify that the above stated maintenance and/or inspection was performed in accordance with the current regulations of the <input checked="" type="checkbox"/> Federal Aviation Administration <input type="checkbox"/> Other (Specify) _____ and _____ THE AIRCRAFT IDENTIFIED ABOVE IS PRESENTLY AIRWORTHY AND APPROVED FOR RETURN TO SERVICE. Work Inspected By <u>NESTOR DERPO</u> Certificate No. <u>11984 - AMT</u> Date <u>31-Mar-2015</u> Pertinent details of this maintenance are on file at our facility under the above Work/Service Order Number as applicable.

Maintenance Log	
Book	Page



Maintenance Transaction Record



This Maintenance Report is To Be Used Solely For (Check One)

Airframe Entries
 Eng. Serial No. _____
 Prop. Serial No. _____

CAMP Systems International
 8200 E. 34TH STREET
 BUILDING 1600, SUITE 1607
 Wichita, KS 67226
 Phone: 316-462-2267/ Fax: 316-462-0791

Aircraft Identification and Status

A/C Serial #	A/C Unit #	A/C Registration #	Date	City ID	Total A/C Hours	Total A/C Landings	Total Engine Hrs	Total Engine Cycles	Total Prop Hrs			
208B-5098		RP-C1087	28-Mar-2015	MNL	265.6	265	265.6	265	265.6			

Component Changes, Inspections, Service Bulletins, or Airworthiness Directives Accomplished

Item	Transaction No.	Type	Item Name	Position	Part Number / Alternate Part Number	Mod Level	Part Serial	Removal Reason	Installed Part Status	TSN/TSO/TSR	Material Costs	Man Hours
215001	1	1	LEFT EVAPORATOR	LEFT	1250327-3		NSN	UN	N	0 MTH 0 HRS		
Comments: Removed part no: 1134380-5 Removed serial no: 961.												

Trans. Type: 1 - Component, 2 - Inspection, 3 - SB, 4 - AD, - - Misc.

Removal Reasons: WO - Worn to Limits, SC - Scheduled, UN - Unscheduled, CO - Convenience, N - Other(note in comments)

Installed Part Status: N - New, R - Repaired/Rebuilt, S - Serviceable, O - Overhauled

Repair Facility _____ Certified Repair Station Number _____ Work Order No. _____ Work Performed By <u>ARISTEO ALCALA</u> Certificate No. <u>115162-AMT</u> Date <u>28-Mar-2015</u> I certify that the above stated maintenance and/or inspection was performed in accordance with the current regulations of the <input type="checkbox"/> Federal Aviation Administration <input checked="" type="checkbox"/> Other (Specify) <u>CAAP</u> and _____ THE AIRCRAFT IDENTIFIED ABOVE IS PRESENTLY AIRWORTHY AND APPROVED FOR RETURN TO SERVICE. Work Inspected By <u>NESTOR DERPO</u> Certificate No. <u>11984 - AMT</u> Date <u>28-Mar-2015</u> Pertinent details of this maintenance are on file at our facility under the above Work/Service Order Number as applicable.
--

Maintenance Log	
Book	Page



Maintenance Transaction Record



This Maintenance Report is To Be Used Solely For (Check One)

Airframe Entries
 Eng. Serial No. _____
 Prop. Serial No. _____

CAMP Systems International
 8200 E. 34TH STREET
 BUILDING 1600, SUITE 1607
 Wichita, KS 67226
 Phone: 316-462-2267/ Fax: 316-462-0791

Aircraft Identification and Status

A/C Serial #	A/C Unit #	A/C Registration #	Date	City ID	Total A/C Hours	Total A/C Landings	Total Engine Hrs	Total Engine Cycles	Total Prop Hrs			
208B-5098		RP-C1087	23-Mar-2015	MNL	249.8	250	249.8	250	249.8			

Component Changes, Inspections, Service Bulletins, or Airworthiness Directives Accomplished

Item	Transaction No.	Type	Item Name	Position	Part Number / Alternate Part Number	Mod Level	Part Serial	Removal Reason	Installed Part Status	TSN/TSO/TSR	Material Costs	Man Hours
051265	1	2	INSPECT 50 HR INSP-FLOATS									
Comments:												
710050	2	2	NO. 1 ENGINE - COMPRESSOR WASH									
Comments:												

Trans. Type: 1 - Component, 2 - Inspection, 3 - SB, 4 - AD, - - Misc.

Removal Reasons: WO - Worn to Limits, SC - Scheduled, UN - Unscheduled, CO - Convenience, N - Other(note in comments)

Installed Part Status: N - New, R - Repaired/Rebuilt, S - Serviceable, O - Overhauled

Repair Facility _____ Certified Repair Station Number _____ Work Order No. _____ Work Performed By <u>CHAZ MICHAEL C DATU</u> Certificate No. <u>126124 -AMT</u> Date <u>23-Mar-2015</u> I certify that the above stated maintenance and/or inspection was performed in accordance with the current regulations of the <input type="checkbox"/> Federal Aviation Administration <input checked="" type="checkbox"/> Other (Specify) <u>CAAP</u> and THE AIRCRAFT IDENTIFIED ABOVE IS PRESENTLY AIRWORTHY AND APPROVED FOR RETURN TO SERVICE. Work Inspected By <u>NESTOR DERPO</u> Certificate No. <u>11984 - AMT</u> Date <u>23-Mar-2015</u> Pertinent details of this maintenance are on file at our facility under the above Work/Service Order Number as applicable.
--

Maintenance Log	
Book	Page



Maintenance Transaction Record



This Maintenance Report is To Be Used Solely For (Check One)

Airframe Entries
 Eng. Serial No. _____
 Prop. Serial No. _____

CAMP Systems International
 8200 E. 34TH STREET
 BUILDING 1600, SUITE 1607
 Wichita, KS 67226
 Phone: 316-462-2267/ Fax: 316-462-0791

Aircraft Identification and Status

A/C Serial #	A/C Unit #	A/C Registration #	Date	City ID	Total A/C Hours	Total A/C Landings	Total Engine Hrs	Total Engine Cycles	Total Prop Hrs			
208B-5098		RP-C1087	10-Mar-2015	MNL	223.5	222	223.5	222	223.5			

Component Changes, Inspections, Service Bulletins, or Airworthiness Directives Accomplished

Item	Transaction No. Type	Item Name	Position	Part Number / Alternate Part Number	Mod Level	Part Serial	Removal Reason	InstalledPart Status TSN/TSO/TSR	Material Costs	Man Hours
051260	1 2	INSPECT 25 HR INSP-FLOATS								
Comments:										

Trans. Type: 1 - Component, 2 - Inspection, 3 - SB, 4 - AD, - - Misc.

Removal Reasons: WO - Worn to Limits, SC - Scheduled, UN - Unscheduled, CO - Convenience, N - Other(note in comments)

Installed Part Status: N - New, R - Repaired/Rebuilt, S - Serviceable, O - Overhauled

Repair Facility _____	Certified Repair Station Number _____	Work Order No. _____
Work Performed By <u>ARISTEO ALCALA</u>	Certificate No. <u>115162-AMT</u>	Date <u>10-Mar-2015</u>
I certify that the above stated maintenance and/or inspection was performed in accordance with the current regulations of the <input type="checkbox"/> Federal Aviation Administration <input checked="" type="checkbox"/> Other (Specify) <u>CAAP</u> and _____		
THE AIRCRAFT IDENTIFIED ABOVE IS PRESENTLY AIRWORTHY AND APPROVED FOR RETURN TO SERVICE.		
Work Inspected By <u>NESTOR DERPO</u>	Certificate No. <u>11984 - AMT</u>	Date <u>10-Mar-2015</u>
Pertinent details of this maintenance are on file at our facility under the above Work/Service Order Number as applicable.		

Maintenance Log	
Book	Page



Maintenance Transaction Record



This Maintenance Report is To Be Used Solely For (Check One)

Airframe Entries
 Eng. Serial No. _____
 Prop. Serial No. _____

CAMP Systems International
 8200 E. 34TH STREET
 BUILDING 1600, SUITE 1607
 Wichita, KS 67226
 Phone: 316-462-2267/ Fax: 316-462-0791

Aircraft Identification and Status

A/C Serial #	A/C Unit #	A/C Registration #	Date	City ID	Total A/C Hours	Total A/C Landings	Total Engine Hrs	Total Engine Cycles	Total Prop Hrs			
208B-5098		RP-C1087	05-Mar-2015	MNL	216.4	216	216.4	216	216.4			

Component Changes, Inspections, Service Bulletins, or Airworthiness Directives Accomplished

Item	Transaction No.	Type	Item Name	Position	Part Number / Alternate Part Number	Mod Level	Part Serial	Removal Reason	Installed Part Status	TSN/TSO/TSR	Material Costs	Man Hours
5-15-06	1	2	INSPECTION DOCUMENT 06									
Comments: satisfactory												
725050	2	2	NO. 1 ENGINE - INSPECT EXHAUST DUCT WELDS									
Comments:												
612010	3	2	NO. 1 PROPELLER - LUBRICATE PROPELLER									
Comments:												
614010	4	2	NO. 1 PROPELLER - INSPECT PROPELLER									
Comments:												
731100	5	2	NO. 1 ENGINE - OPERATIONAL CHECK CONTROL MANUAL OVERRIDE STATIC SYSTEM									
Comments:												

Trans. Type: 1 - Component, 2 - Inspection, 3 - SB, 4 - AD, - - Misc.

Removal Reasons: WO - Worn to Limits, SC - Scheduled, UN - Unscheduled, CO - Convenience, N - Other(note in comments)

Installed Part Status: N - New, R - Repaired/Rebuilt, S - Serviceable, O - Overhauled

Repair Facility _____	Certified Repair Station Number _____	Work Order No. _____
Work Performed By <u>CHAZ MICHAEL C DATU</u>	Certificate No. <u>126124 -AMT</u>	Date <u>05-Mar-2015</u>
I certify that the above stated maintenance and/or inspection was performed in accordance with the current regulations of the <input type="checkbox"/> Federal Aviation Administration <input checked="" type="checkbox"/> Other (Specify) <u>CAAP</u> and		
THE AIRCRAFT IDENTIFIED ABOVE IS PRESENTLY AIRWORTHY AND APPROVED FOR RETURN TO SERVICE.		
Work Inspected By <u>NESTOR DERPO</u>	Certificate No. <u>11984 - AMT</u>	Date <u>05-Mar-2015</u>
Pertinent details of this maintenance are on file at our facility under the above Work/Service Order Number as applicable.		

Maintenance Log	
Book	Page



Maintenance Transaction Record



This Maintenance Report is To Be Used Solely For (Check One)

Airframe Entries
 Eng. Serial No. _____
 Prop. Serial No. _____

CAMP Systems International
 8200 E. 34TH STREET
 BUILDING 1600, SUITE 1607
 Wichita, KS 67226
 Phone: 316-462-2267/ Fax: 316-462-0791

Aircraft Identification and Status

A/C Serial #	A/C Unit #	A/C Registration #	Date	City ID	Total A/C Hours	Total A/C Landings	Total Engine Hrs	Total Engine Cycles	Total Prop Hrs			
208B-5098		RP-C1087	05-Mar-2015	MNL	216.4	216	216.4	216	216.4			

Component Changes, Inspections, Service Bulletins, or Airworthiness Directives Accomplished

Item	Transaction No.	Type	Item Name	Position	Part Number / Alternate Part Number	Mod Level	Part Serial	Removal Reason	InstalledPart Status	TSN/TSO/TSR	Material Costs	Man Hours
334002	1	1	RIGHT NAV LIGHTS & STROBES- R WING TIP TIP	RIGHT	01-0790613-91		00314	N	N			
Comments: Removed part no: 01-0790613-91 Removed serial no: 00235. DUE TO FAIL.												

Trans. Type: 1 - Component, 2 - Inspection, 3 - SB, 4 - AD, - - Misc.

Removal Reasons: WO - Worn to Limits, SC - Scheduled, UN - Unscheduled, CO - Convenience, N - Other(note in comments)

Installed Part Status: N - New, R - Repaired/Rebuilt, S - Serviceable, O - Overhauled

Repair Facility _____ Certified Repair Station Number _____ Work Order No. _____ Work Performed By <u>CHAZ MICHAEL C DATU</u> Certificate No. <u>126124 -AMT</u> Date <u>05-Mar-2015</u> I certify that the above stated maintenance and/or inspection was performed in accordance with the current regulations of the <input type="checkbox"/> Federal Aviation Administration <input checked="" type="checkbox"/> Other (Specify) <u>CAAP</u> and _____ THE AIRCRAFT IDENTIFIED ABOVE IS PRESENTLY AIRWORTHY AND APPROVED FOR RETURN TO SERVICE. Work Inspected By <u>NESTOR DERPO</u> Certificate No. <u>11984 - AMT</u> Date <u>05-Mar-2015</u> Pertinent details of this maintenance are on file at our facility under the above Work/Service Order Number as applicable.
--

Maintenance Log	
Book	Page



Maintenance Transaction Record



This Maintenance Report is To Be Used Solely For (Check One)

Airframe Entries
 Eng. Serial No. _____
 Prop. Serial No. _____

CAMP Systems International
 8200 E. 34TH STREET
 BUILDING 1600, SUITE 1607
 Wichita, KS 67226
 Phone: 316-462-2267/ Fax: 316-462-0791

Aircraft Identification and Status

A/C Serial #	A/C Unit #	A/C Registration #	Date	City ID	Total A/C Hours	Total A/C Landings	Total Engine Hrs	Total Engine Cycles	Total Prop Hrs			
208B-5098		RP-C1087	02-Mar-2015	MNL	202.3	209	202.3	209	202.3			

Component Changes, Inspections, Service Bulletins, or Airworthiness Directives Accomplished

Item	Transaction No.	Type	Item Name	Position	Part Number / Alternate Part Number	Mod Level	Part Serial	Removal Reason	InstalledPart Status	TSN/TSO/TSR	Material Costs	Man Hours
051260	1	2	INSPECT 25 HR INSP-FLOATS									
Comments:												
051265	2	2	INSPECT 50 HR INSP-FLOATS									
Comments:												
051270	3	2	INSPECT 100 HR INSP-FLOATS									
Comments:												
051275	4	2	INSPECT 200 HR INSP-FLOATS									
Comments:												

Trans. Type: 1 - Component, 2 - Inspection, 3 - SB, 4 - AD, - - Misc.

Removal Reasons: WO - Worn to Limits, SC - Scheduled, UN - Unscheduled, CO - Convenience, N - Other(note in comments)

Installed Part Status: N - New, R - Repaired/Rebuilt, S - Serviceable, O - Overhauled

Repair Facility _____ Certified Repair Station Number _____ Work Order No. _____ Work Performed By <u>ARISTEO ALCALA</u> Certificate No. <u>115162</u> Date <u>02-Mar-2015</u> I certify that the above stated maintenance and/or inspection was performed in accordance with the current regulations of the <input type="checkbox"/> Federal Aviation Administration <input checked="" type="checkbox"/> Other (Specify) <u>CAAP</u> and _____ THE AIRCRAFT IDENTIFIED ABOVE IS PRESENTLY AIRWORTHY AND APPROVED FOR RETURN TO SERVICE. Work Inspected By <u>NESTOR DERPO</u> Certificate No. <u>11984</u> Date <u>02-Mar-2015</u> Pertinent details of this maintenance are on file at our facility under the above Work/Service Order Number as applicable.
--

Maintenance Log	
Book	Page



Maintenance Transaction Record



This Maintenance Report is To Be Used Solely For (Check One)

Airframe Entries Eng. Serial No. _____ Prop. Serial No. _____

CAMP Systems International
8200 E. 34TH STREET
BUILDING 1600, SUITE 1607
Wichita, KS 67226
Phone: 316-462-2267/ Fax: 316-462-0791

Aircraft Identification and Status

A/C Serial #	A/C Unit #	A/C Registration #	Date	City ID	Total A/C Hours	Total A/C Landings	Total Engine Hrs	Total Engine Cycles	Total Prop Hrs			
208B-5098		RP-C1087	02-Mar-2015	MNL	202.3	205	202.3	205	202.3			

Component Changes, Inspections, Service Bulletins, or Airworthiness Directives Accomplished

Item	Transaction No.	Type	Item Name	Position	Part Number / Alternate Part Number	Mod Level	Part Serial	Removal Reason	Installed Part Status	TSN/TSO/TSR	Material Costs	Man Hours
320302F	1	1	RIGHT INBOARD (FLOAT) WHEEL ASSEMBLY	RIGHT INBOARD	8A04000-031		NSN	N	N	0 MTH 0 HRS		
Comments: Removed part no: 8A04000-031 Removed serial no: SN-UNKNOWN.												
320801F	2	1	LEFT NOSE (FLOAT) WHEEL ASSEMBLY	LEFT	8A06000-008		NSN	N	N	0 MTH 0 HRS		
Comments: Removed part no: 8A06000-008 Removed serial no: SN-UNKNOWN.												
320801F	3	1	RIGHT NOSE (FLOAT) WHEEL ASSEMBLY	RIGHT	8A06000-008		NSN	N	N	0 MTH 0 HRS		
Comments: Removed part no: PN Removed serial no: SN-UNKNOWN.												
321108F	4	1	RIGHT INBOARD BRAKE DISC	RIGHT INBOARD	A64-24500		NSN	N	N	0 MTH 0 HRS		
Comments: Removed part no: PN Removed serial no: SN-UNKNOWN.												
321106F 321106F : RI	5	1	RIGHT INBOARD BRAKE PRESSURE PLATE	RIGHT INBOARD	PN073-04200		NSN	N	N	0 MTH 0 HRS		
Comments: Removed part no: PN Removed serial no: SN-UNKNOWN.												
321110F 321110F : RI	6	1	RIGHT INBOARD BRAKE BACK PLATE	RIGHT INBOARD	PN074-002900		NSN	N	N	0 MTH 0 HRS		
Comments: Removed part no: PNP073-04200 Removed serial no: SN-UNKNOWN.												
321106F 321106F : LI	7	1	LEFT INBOARD BRAKE PRESSURE PLATE	LEFT INBOARD	PN073-04200		NSN	N	N	0 MTH 0 HRS		
Comments: Removed part no: PN Removed serial no: SN-UNKNOWN.												
321106F 321106F : RO	8	1	RIGHT OUTBOARD BRAKE PRESSURE PLATE	RIGHT OUTBOARD	PN073-04200		NSN	N	N	0 MTH 0 HRS		
Comments: Removed part no: PN073-04200 serial no: SN-UNKNOWN.												

Trans. Type: 1 - Component, 2 - Inspection, 3 - SB, 4 - AD, - - Misc.

Removal Reasons: WO - Worn to Limits, SC - Scheduled, UN - Unscheduled, CO - Convenience, N - Other(note in comments)

Installed Part Status: N - New, R - Repaired/Rebuilt, S - Serviceable, O - Overhauled

Repair Facility _____	Certified Repair Station Number _____	Work Order No. _____
Work Performed By <u>CHAZ MICHAEL C DATU</u>	Certificate No. <u>126124 -AMT</u>	Date <u>02-Mar-2015</u>
I certify that the above stated maintenance and/or inspection was performed in accordance with the current regulations of the		
<input type="checkbox"/> Federal Aviation Administration <input checked="" type="checkbox"/> Other (Specify) <u>CAAP</u> and		
THE AIRCRAFT IDENTIFIED ABOVE IS PRESENTLY AIRWORTHY AND APPROVED FOR RETURN TO SERVICE.		
Work Inspected By <u>NESTOR DERPO</u>	Certificate No. <u>11984 - AMT</u>	Date <u>02-Mar-2015</u>
Pertinent details of this maintenance are on file at our facility under the above Work/Service Order Number as applicable.		

Maintenance Log	
Book	Page



Maintenance Transaction Record



This Maintenance Report is To Be Used Solely For (Check One)

Airframe Entries
 Eng. Serial No. _____
 Prop. Serial No. _____

CAMP Systems International
 8200 E. 34TH STREET
 BUILDING 1600, SUITE 1607
 Wichita, KS 67226
 Phone: 316-462-2267/ Fax: 316-462-0791

Aircraft Identification and Status

A/C Serial #	A/C Unit #	A/C Registration #	Date	City ID	Total A/C Hours	Total A/C Landings	Total Engine Hrs	Total Engine Cycles	Total Prop Hrs			
208B-5098		RP-C1087	02-Mar-2015	MNL	202.3	205	202.3	205	202.3			

Component Changes, Inspections, Service Bulletins, or Airworthiness Directives Accomplished

Item	Transaction No.	Type	Item Name	Position	Part Number / Alternate Part Number	Mod Level	Part Serial	Removal Reason	Installed Part Status	TSN/TSO/TSR	Material Costs	Man Hours
321106F 321106F : LO	9	1	LEFT OUTBOARD BRAKE PRESSURE PLATE	LEFT OUTBOARD	PN 073-4200		NSN	N	N	0 MTH 0 HRS		
Comments: Removed part no: PN073-04200 serial no: SN-UNKNOWN.												
321110F 321110F : LI	10	1	LEFT INBOARD BRAKE BACK PLATE	LEFT INBOARD	PN07302900		NSN	N	N	0 MTH 0 HRS		
Comments: Removed part no: PN Removed serial no: SN-UNKNOWN.												
321110F 321110F : LO	11	1	LEFT OUTBOARD BRAKE BACK PLATE	LEFT OUTBOARD	PN074-02900		NSN	N	N	0 MTH 0 HRS		
Comments: Removed part no: PN074-02900 Removed serial no: NSN												
321110F 321110F : RO	12	1	RIGHT OUTBOARD BRAKE BACK PLATE	RIGHT OUTBOARD	PN074-02900		NSN	N	N	0 MTH 0 HRS		
Comments: Removed part no: PN074-02900 serial no: NSN												

Trans. Type: 1 - Component, 2 - Inspection, 3 - SB, 4 - AD, - - Misc.

Removal Reasons: WO - Worn to Limits, SC - Scheduled, UN - Unscheduled, CO - Convenience, N - Other(note in comments)

Installed Part Status: N - New, R - Repaired/Rebuilt, S - Serviceable, O - Overhauled

Repair Facility _____	Certified Repair Station Number _____	Work Order No. _____
Work Performed By <u>CHAZ MICHAEL C DATU</u>	Certificate No. <u>126124 -AMT</u>	Date <u>02-Mar-2015</u>
I certify that the above stated maintenance and/or inspection was performed in accordance with the current regulations of the <input type="checkbox"/> Federal Aviation Administration <input checked="" type="checkbox"/> Other (Specify) <u>CAAP</u> and		
THE AIRCRAFT IDENTIFIED ABOVE IS PRESENTLY AIRWORTHY AND APPROVED FOR RETURN TO SERVICE.		
Work Inspected By <u>NESTOR DERPO</u>	Certificate No. <u>11984 - AMT</u>	Date <u>02-Mar-2015</u>
Pertinent details of this maintenance are on file at our facility under the above Work/Service Order Number as applicable.		

Maintenance Log	
Book	Page



Maintenance Transaction Record



This Maintenance Report is To Be Used Solely For (Check One)

Airframe Entries Eng. Serial No. _____ Prop. Serial No. _____

CAMP Systems International
8200 E. 34TH STREET
BUILDING 1600, SUITE 1607
Wichita, KS 67226
Phone: 316-462-2267/ Fax: 316-462-0791

Aircraft Identification and Status

A/C Serial #	A/C Unit #	A/C Registration #	Date	City ID	Total A/C Hours	Total A/C Landings	Total Engine Hrs	Total Engine Cycles	Total Prop Hrs			
208B-5098		RP-C1087	16-Feb-2015	MNL	173.9	167	173.9	167	173.9			

Component Changes, Inspections, Service Bulletins, or Airworthiness Directives Accomplished

Item	Transaction No.	Type	Item Name	Position	Part Number / Alternate Part Number	Mod Level	Part Serial	Removal Reason	Installed Part Status	TSN/TSO/TSR	Material Costs	Man Hours
051260	1	2	INSPECT 25 HR INSP-FLOATS									
Comments:												

Trans. Type: 1 - Component, 2 - Inspection, 3 - SB, 4 - AD, - - Misc.

Removal Reasons: WO - Worn to Limits, SC - Scheduled, UN - Unscheduled, CO - Convenience, N - Other(note in comments)

Installed Part Status: N - New, R - Repaired/Rebuilt, S - Serviceable, O - Overhauled

Repair Facility _____	Certified Repair Station Number _____	Work Order No. _____
Work Performed By <u>CHAZ MICHAEL C DATU</u>	Certificate No. <u>126124</u>	Date <u>16-Feb-2015</u>
I certify that the above stated maintenance and/or inspection was performed in accordance with the current regulations of the <input type="checkbox"/> Federal Aviation Administration <input checked="" type="checkbox"/> Other (Specify) <u>CAAP</u> and _____		
THE AIRCRAFT IDENTIFIED ABOVE IS PRESENTLY AIRWORTHY AND APPROVED FOR RETURN TO SERVICE.		
Work Inspected By <u>NESTOR DERPO</u>	Certificate No. <u>11984</u>	Date <u>16-Feb-2015</u>
Pertinent details of this maintenance are on file at our facility under the above Work/Service Order Number as applicable.		

Maintenance Log	
Book	Page



Maintenance Transaction Record



This Maintenance Report is To Be Used Solely For (Check One)

Airframe Entries
 Eng. Serial No. _____
 Prop. Serial No. _____

CAMP Systems International
 8200 E. 34TH STREET
 BUILDING 1600, SUITE 1607
 Wichita, KS 67226
 Phone: 316-462-2267/ Fax: 316-462-0791

Aircraft Identification and Status

A/C Serial #	A/C Unit #	A/C Registration #	Date	City ID	Total A/C Hours	Total A/C Landings	Total Engine Hrs	Total Engine Cycles	Total Prop Hrs			
208B-5098	5098	N8159N	09-Mar-2014	ICT	1.3	1	1.3	1	1.3			

Component Changes, Inspections, Service Bulletins, or Airworthiness Directives Accomplished

Item	Transaction No. Type	Item Name	Position	Part Number / Alternate Part Number	Mod Level	Part Serial	Removal Reason	InstalledPart Status TSN/TSO/TSR	Material Costs	Man Hours
2261524	1 -	EXPORT CERTIFICATE								
Comments: This Aircraft has been inspected and is found to be in a condition for safe operation. Export # E455590 has been issued on 03/09/2014										
Moreno L Mitchell ODA-100129-CE										

Trans. Type: 1 - Component, 2 - Inspection, 3 - SB, 4 - AD, - - Misc.

Removal Reasons: WO - Worn to Limits, SC - Scheduled, UN - Unscheduled, CO - Convenience, N - Other(note in comments)

Installed Part Status: N - New, R - Repaired/Rebuilt, S - Serviceable, O - Overhauled

Repair Facility _____ Certified Repair Station Number _____ Work Order No. _____ Work Performed By _____ Certificate No. _____ Date 09-Mar-2014 I certify that the above stated maintenance and/or inspection was performed in accordance with the current regulations of the <input checked="" type="checkbox"/> Federal Aviation Administration <input type="checkbox"/> Other (Specify) _____ and _____ Work Inspected By _____ Certificate No. _____ Date 09-Mar-2014 Pertinent details of this maintenance are on file at our facility under the above Work/Service Order Number as applicable.

Maintenance Log	
Book	Page